

# World Engineering Forum 2012

[www.wef2012.si](http://www.wef2012.si)

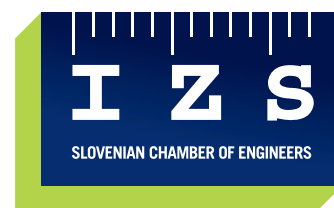

## Sustainable Construction for People

17 – 21 September 2012, Ljubljana, Slovenia



# Contents

- 011** **Dr. Milan Medved, Slovenia**  
**Mining Engineering and Sustainable Development – the Case of Premogovnik Velenje**  
Velenje Coal Mine  
E-mail: [milan.medved@rlv.si](mailto:milan.medved@rlv.si)

## CITIES AND URBAN ENVIRONMENT

- 015** **Dr. Strahinja Trpevski, F.Y.R.O.M.**  
**Challenges on the Path to Sustainable Construction for EU Candidate Countries**  
Chamber of Authorized Architects and Engineers of Macedonia  
E-mail: [strahinja\\_trpevski@yahoo.co.uk](mailto:strahinja_trpevski@yahoo.co.uk)
- 023** **Robert Smodiš, Slovenia**  
**Sustainable Multigenerational House as a Response to Global Urbanization**  
Green Building Council Slovenia  
E-mail: [robert.smodis@kema.si](mailto:robert.smodis@kema.si)
- 029** **Prof. Janez Koželj, Slovenia**  
**City of Ljubljana on the Way to a Sustainable Future 2007–2011**  
Deputy Mayor of Ljubljana Municipality, professor at the Faculty of Architecture,  
University of Ljubljana  
E-mail: [janez.kozelj@ljubljana.si](mailto:janez.kozelj@ljubljana.si)
- 037** **Er. Seng Chuan Tan, M L Fam, T W Lee and S C Tan, Singapore**  
**A Singapore Story: From Concrete Jungle to Liveable City**  
Institution of Engineers Singapore  
E-mail: [SengChuan.Tan@ch2m.com](mailto:SengChuan.Tan@ch2m.com)
- 045** **Camilo Santamaría-Gamboa, Colombia**  
**Sustainable Cities: Stockholm and the New Neighbourhood of Hammarby**  
Colombian Construction Council of Sustainability  
E-mail: [csantamaria@santamariaurbanismo.com](mailto:csantamaria@santamariaurbanismo.com)
- 049** **Prof. Dr. Adel S. El Menchawy, Egypt**  
**Ecoresorts – A Type of Sustainable Architecture**  
AASTMT – Arab Academy for Science and Technology and Martím Transport  
E-mail: [dradelsamy@yahoo.com](mailto:dradelsamy@yahoo.com)

- 057 Prof. Dr. Daniel Favrat, Switzerland**  
**Efficient Energy Systems for Buildings and Cities**  
 Swiss Federal Institute of Technology of Lausanne  
 E-mail: [daniel.favrat@epfl.ch](mailto:daniel.favrat@epfl.ch)
- 065 Prof. Dr. Lars Bylund, Sweden**  
**Energy Autonomous Urbanisations for Emerging Economies and Developing Countries**  
 Bergen School of Architecture, Norway, DigiEcoCity, Finland  
 E-mail: [lars.bylund@yahoo.se](mailto:lars.bylund@yahoo.se)
- 073 Prof. Dr. Tai Sik Lee, South Korea**  
**Sustainable Engineering for Extreme Environments – Earth & Space**  
 Korean Federation of Engineering Organizations  
 E-mail: [cmtsl@hanyang.ac.kr](mailto:cmtsl@hanyang.ac.kr)
- 077 Dimitar Natchev, Maria Stefanova**  
**Standards for Sustainable Construction**  
 Bulgarian Institut for Standartization, Chamber of Engineers in the Investment Design, Sofia  
 E-mail: [d\\_natchev@kiip-sofia.com](mailto:d_natchev@kiip-sofia.com) / [m\\_stefanova@kiip-sofia.com](mailto:m_stefanova@kiip-sofia.com)

## SUSTAINABLE INFRASTRUCTURE

- 107 Prof. Abubakar Sani, Sambo, J.S. Olayande & B.F.I. Sulu, Nigeria**  
**Estimation of Energy Demand in the Building and Construction Section of the Nigerian Economy**  
 Energy Commission of Nigeria  
 E-mail: [assambo@yahoo.com](mailto:assambo@yahoo.com)
- 117 Dr. Vilas Mujumdar, U.S.A.**  
**Sustainable and Resilient Infrastructure and Housing – A Need for Enhanced Quality of Life**  
 American Association of Engineering Societies  
 E-mail: [v\\_mujumdar41@yahoo.com](mailto:v_mujumdar41@yahoo.com)
- 125 Mag. Danijel Zupančič, Slovenia**  
**The Aspect of Sustainable Development in Engineering Practice**  
 Trimo d.d.  
 E-mail: [danijel.zupancic@trimo.si](mailto:danijel.zupancic@trimo.si)
- 131 Prof. Dr. Carsten D. Ahrens, Germany**  
**Offshore Wind Energy and Civil Engineering in Germany – A Green and Sustainable Partnership**  
 University of Applied Sciences Jade-Hochschule, Zentralverband Deutscher Ingenieure,  
 World Council of Civil Engineers  
 E-mail: [carsten.ahrens@jade-hs.de](mailto:carsten.ahrens@jade-hs.de)
- 143 Pradeep Chaturvedi, India**  
**Renewable Energy Systems**  
 WFEO Energy Committee  
 E-mail: [pradeepc08@gmail.com](mailto:pradeepc08@gmail.com)

- 149 Prof. Mauricio Porraz, Mexico**  
**Ocean and Coastal Engineering**  
Academia de Ingenieria  
E-mail: [mauricio@porraz.com](mailto:mauricio@porraz.com)
- 153 Dr. Ana Mladenović, Darko Kokot, Alenka Mauko, Zvonko Cotič, Stanislav Lenart, Karmen Fifer Bizjak, Slovenia**  
**Waste as a Resource in Building and Civil Engineering – the Current Situation in Slovenia**  
Slovenian National Building and Civil Engineering Institute, Primorje d.d.  
E-mail: [ana.mladenovic@zag.si](mailto:ana.mladenovic@zag.si)
- 161 Dr. Marjana Šijanec Zavrl, M. Sc. Miha Tomšič, Dr. Henrik Gjerkeš, Slovenia**  
**Integration of Nearly Zero Energy Buildings in Sustainable Networks– a Challenge for Sustainable Building Stock**  
Building and Civil Engineering Institute ZRMK, Slovenia  
E-mail: [marjana.sijanec@gi-zrmk.si](mailto:marjana.sijanec@gi-zrmk.si) / [henrik.gjerkes@gi-zrmk.si](mailto:henrik.gjerkes@gi-zrmk.si) / [miha.tomsic@gi-zrmk.si](mailto:miha.tomsic@gi-zrmk.si)
- 167 Miloš Todorović, Slovenia**  
**Benefits of BIM and a Multidisciplinary Collaborative Environment**  
University of Ljubljana, Faculty of Civil Engineering and Geodesy  
E-mail: [milos@bim.si](mailto:milos@bim.si)
- 175 Dr. Emilio M. Colón, Eduardo Colón, Puerto Rico**  
**Tablets Simplify Construction Management**  
World Council of Civil Engineers  
E-mail: [secretariat@wcce.net](mailto:secretariat@wcce.net) / [president@wcce.net](mailto:president@wcce.net)
- 189 Albert Otto, Nigeria**  
**Sustainable Construction: Towards a Paradigm Shift in the Built Development Approach**  
Fugro Nigeria Limited  
E-mail: [cedarmarble@yahoo.com](mailto:cedarmarble@yahoo.com)

## DISASTER RISK MANAGEMENT

- 207 Prof. Kazutoshi Kan, Kazutoshi Osawa, Japan**  
**The Influence of Development on the Amount of Red-Clay Runoff in the Republic of Palau**  
Shibaura Institute of Technology  
E-mail: [kan@sic.shibaura-it.ac.jp](mailto:kan@sic.shibaura-it.ac.jp)
- 215 Dr. Marlene Kanga, Australia**  
**Systematic Natural Disaster Risk Management for Sustainable Development**  
Engineers Australia  
E-mail: [marlenekanga@bigpond.com](mailto:marlenekanga@bigpond.com)
- 221 Dr. Kazumasa Ito, Japan**  
**Extraordinary Flood Management Project in the Tokyo Metropolitan Area**  
CTI Engineering Co., LTD  
E-mail: [k-ito@ctie.co.jp](mailto:k-ito@ctie.co.jp)

- 231 Assist. Prof. Dr. Stanislav Lenart, Slovenia and F. Tatsuoka, J. Koseki, Japan**  
**Use of Reinforced Soil as a Natural Disaster Countermeasure**  
Slovenian National Building and Civil Engineering Institute  
E-mail: [stanislav.lenart@zag.si](mailto:stanislav.lenart@zag.si)
- 245 Dr. Yumio Ishii, Japan**  
**Damages and Evaluation of Investment in Integrated Disaster Risk Management**  
CTI Engineering Co., LTD  
E-mail: [ishii@ctie.co.jp](mailto:ishii@ctie.co.jp)
- 255 Dr. Vilas Mujumdar, U.S.A.**  
**Understanding Vulnerability of Critical Infrastructure Systems to Reduce the Impact of Natural Hazard on Societal Functionality**  
American Association of Engineering Societies  
E-mail: [v\\_mujumdar41@yahoo.com](mailto:v_mujumdar41@yahoo.com)
- 265 Dr. Chan Wirasinghe, S. W. Durage, S.C. Wirasinghe, J. Ruwanpura, Canada**  
**An Introduction to False Tornado Warnings in Canada**  
The Schulich School of Engineering  
E-mail: [wirasing@ucalgary.ca](mailto:wirasing@ucalgary.ca)
- 273 Dr. Leon Cizelj, Slovenia**  
**The Augmented Role of Education and Research in the Safety of Nuclear Power Plants**  
Jozef Stefan Institute, Ljubljana, Reactor Engineering Division  
E-mail: [leon.cizelj@ijs.si](mailto:leon.cizelj@ijs.si)
- 281 Dr. Yasuyuki Shimizu, Japan**  
**Effects of the First Flood Control Plan and River Improvements on the Ishikari River Basin**  
Hokkaido University, Faculty of Engineering  
E-mail: [yasu@eng.hokudai.ac.jp](mailto:yasu@eng.hokudai.ac.jp)
- 287 Prof. Dr. Matjaz Četina, Slovenia**  
**Computations of Dam-Break Waves in Slovenia**  
University of Ljubljana, Faculty of Civil and Geodetic Engineering  
E-mail: [matjaz.cetina@fgg.uni-lj.si](mailto:matjaz.cetina@fgg.uni-lj.si)
- 299 Dr. Syunsuke Ikeda, Japan**  
**Recovery and Job Development in the Aftermath of the Great East Japan Earthquake**  
**Disaster – The Situation after One Year of the Disaster**  
Science Council of Japan Cabinet Office  
E-mail: [sk-ikeda@ctie.co.jp](mailto:sk-ikeda@ctie.co.jp)
- 307 Dr. Keiko Tamura, Takashi Furuya, Haruo Hayashi, Japan**  
**Web-Based Victims Master Database System for Effective Support in Victims' Life**  
**Reconstruction Process-A Study of 2011 Earthquake off the Pacific Coast of Tohoku**  
Risk Management Office, Niigata University, Japan  
E-mail: [tamura@gs.niigata-u.ac.jp](mailto:tamura@gs.niigata-u.ac.jp)
- 313 Ashok Basa, India**  
**The 2004 Indian Ocean Tsunami – Impact on India**  
The Institution of Engineers – Civil Engineering Division Board, B. Engineeres & Builders Ltd., Bhubaneswar  
E-mail: [b\\_eb@hotmail.com](mailto:b_eb@hotmail.com)

**325 Marc W. Goldsmith, U.S.A.**  
**Risk Mitigation in Increasingly Complex Systems**  
ASME President  
E-mail: [MichaudM@asme.org](mailto:MichaudM@asme.org)

## GREEN BUILDINGS

**333 Vincent Briard, France**  
**Environmental Performance Matters, what Impacts on the Construction Sector**  
Knauf Insulation  
E-mail: [vincent.briard@knaufinsulation.com](mailto:vincent.briard@knaufinsulation.com)

**337 Gerald Fuxjäger, Austria**  
**Life Cycle Cost**  
Chamber of Architects and Civil Engineers of Styria and Carinthia  
E-mail: [armin.ruhri@ztkammer.at](mailto:armin.ruhri@ztkammer.at)

**343 Dr. Ljudmila Koprivec, Slovenia**  
**The Influence of Contemporary Materials and Technologies on the Building Envelope**  
Trimo, d.d.  
E-mail: [ljudmila.koprivec@guest.arnes.si](mailto:ljudmila.koprivec@guest.arnes.si)

**349 Prof. Dr. Dragoslav Šumarac, Assist. Prof. Dr. Maja Todorović, Serbia**  
**The Way to Energy Efficient Buildings and the Savings Potential in the Republic of Serbia**  
Serbian Chamber of Engineers  
E-mail: [sumi@EUnet.rs](mailto:sumi@EUnet.rs) / [mtodorovic@mas.bg.ac.rs](mailto:mtodorovic@mas.bg.ac.rs)

**353 Friderik Knez, Katja Slanc, Slovenia**  
**Experience in Ecobalancing of Buildings in Slovenia**  
Slovenian National Building and Civil Engineering Institute  
E-mail: [friderik.knez@zag.si](mailto:friderik.knez@zag.si)

**359 Mladenka Dabac, Croatia**  
**Renewable Energy Sources / Res Way Towards Green Tourism**  
Dabacarhitects d.o.o  
E-mail: [dabacarchitects@web.de](mailto:dabacarchitects@web.de)

**361 Barry Lynham, France**  
**Delivering Low Energy Buildings that Work in Reality**  
Knauf Insulation  
E-mail: [barry.lynham@knaufinsulation.com](mailto:barry.lynham@knaufinsulation.com)

**367 Dr. Matjaž Žnidaršič, Slovenia**  
**A High-Tech Green Building**  
CBS Institute  
E-mail: [matjaz.znidarsic@cbs-institut.si](mailto:matjaz.znidarsic@cbs-institut.si)

- 375 Dr. Roumiana Zaharieva, Dr. Yana Kancheva, Bulgaria**  
**Measures to Decrease the Environmental Footprint of Concrete**  
University of Architecture, Civil Engineering and Geodesy  
E-mail: [roumiana.zaharieva@gmail.com](mailto:roumiana.zaharieva@gmail.com) / [ykancheva@gmail.com](mailto:ykancheva@gmail.com)
- 385 Sabina Jordan, MSc, Slovenia**  
**Tilmann E. Kuhn, BSc Phys., Germany**  
**Ljubljana's Pilot Demonstration of an EU Project Cost Effective**  
Slovenian National Building and Civil Engineering Institute  
Fraunhofer Institute for Solar Energy Systems ISE  
E-mail: [sabina.jordan@zag.si](mailto:sabina.jordan@zag.si) / [tilmann.kuhn@ise.fraunhofer.de](mailto:tilmann.kuhn@ise.fraunhofer.de)
- 391 Dragan Vuković, Nebojša Adžić, Montenegro**  
**The First Private Environmental and Energy-Efficient Building in Montenegro –  
A Case Study**  
Engineers Chamber of Montenegro  
E-mail: [dragan.vukovic@greenhouse.co.me](mailto:dragan.vukovic@greenhouse.co.me) / [nebojsa.adzic@gmail.com](mailto:nebojsa.adzic@gmail.com)
- 395 Dr. Frank Heinlein, Germany**  
**Making Sustainability Visible!**  
DGNB (German Sustainable Building Council)  
E-mail: [Frank.Heinlein@WernerSobek.com](mailto:Frank.Heinlein@WernerSobek.com)
- 403 Brian Kyle, Canada**  
**Green Building Rating Systems, Sustainability & Standardisation of Practise**  
World Federation of Engineering Organizations – Committee on Engineering  
and the Environment, Ottawa  
E-mail: [brian.kyle@xtn-slam.com](mailto:brian.kyle@xtn-slam.com)
- 413 Aleksander Lehmden, Austria**  
**The road to the – “Nearly Zero Energy Building”**  
Wienerberger AG  
E-mail: [Alexander.Lehmden@wienerberger.com](mailto:Alexander.Lehmden@wienerberger.com)
- 417 Martin Feder, United Kingdom**  
**Integrated Solutions Designed for High Performance and Sustained Results**  
Director, EMEA SmartStruxure Launch  
E-mail: [Martin.Feder@schneider-electric.com](mailto:Martin.Feder@schneider-electric.com)
- 421 Dr. Natalie Essig, Vincent Peyramale, Germany**  
**Dr. Marjana Šijanec Zavrl**  
**Open House: European Open Source Metodology to Assess the Sustainability  
of Buildings**  
Fraunhofer-Institute for Building Physics IBP  
ZRMK  
E-mail: [natalie.essig@ibp.fraunhofer.de](mailto:natalie.essig@ibp.fraunhofer.de) / [vincent.peyramale@ibp.fraunhofer.de](mailto:vincent.peyramale@ibp.fraunhofer.de)  
[marjana.sijanec@gi-zrmk.si](mailto:marjana.sijanec@gi-zrmk.si)



## Dear participants of the World Engineering Forum – WEF 2012,



Welcome to Ljubljana, the capital of Slovenia, where over the next two days 60 eminent speakers from more than 30 countries around the world will present the latest approaches to sustainable construction and develop new ideas for the green economy. The World Federation of Engineering Organisations (WFEO) with more than 90 national members and the Slovenian Chamber of Engineers are together hosting over 600 guests from all continents.

The objective of the Forum on Sustainable Construction for People is to bring the profession, the economy and politics together in order to help relaunch the building sector that is currently facing one of the toughest crises in history. In the decades to come, the main design and construction development challenge will be characterised by a shortage of energy and water. I believe that engineers possess all necessary competencies and ideas that will ensure a safe, clean and healthy future for our planet.

The International Advisory Board selected speakers for the four forum sessions: Cities and Urban Environment, Sustainable Infrastructure, Green Buildings and Disaster/Risk Management. The most relevant conclusions of the WEF 2012 topics will be added to the declaration of the Rio +20 – WFEO Seminar on Sustainable Communities and a common statement will be formulated and presented at the Closing Ceremony of the forum. On the next day it will be formally approved by the WFEO Executive Council.

Respected participants of the World Engineering Forum 2012, in the name of the organiser, the Slovenian Chamber of Engineers, I wish you all successful work, fruitful discussions and a pleasant stay in Ljubljana, one of the most beautiful cities in the world.

Ljubljana, September 2012

A handwritten signature in blue ink, appearing to read 'Remec', written in a cursive style.

Mag. Črtomir Remec  
President of the Slovenian Chamber of Engineers  
President of the National Organising Committee of WEF 2012



# Dr. Milan Medved, Slovenia



## Mining Engineering and Sustainable Development – the Case of Premogovnik Velenje

Velenje Coal Mine

E-mail: [milan.medved@rlv.si](mailto:milan.medved@rlv.si)

### ABSTRACT

Premogovnik Velenje, the Velenje Coal Mine, serves as a reference mine for underground coal mining in Europe according to international reviewers. As a technologically advanced company going back over 137 years, it is firmly rooted in the Slovene energy industry and the local environment, while preserving a strong sense of social responsibility. As a company that maintains competitive production of local coal, covering one third of total electricity needs in Slovenia, copes with environmental issues, provides quality jobs in coal production and creates new ones with its other activities, Premogovnik Velenje meets all the crucial factors of sustainable development.

Regular modernisation of coal production is one of the company's strategic goals, contributing to better working conditions and a greater economic and environmental acceptability. Therefore, its production follows the principles of sustainable development, with all activities in line with the following international standards: ISO 9001 for quality management systems, ISO 14001 for environmental management systems, and OHSAS 18001 for occupational health and safety. In order to secure even more efficient energy management, the company was the first coal mine in the world to earn certification under the ISO 50001 international standard promoting energy efficiency.

Aiming to maintain coal mining in line with the principles of sustainable development, Premogovnik Velenje has significantly reduced its environmental impact. Thus, when coming to Velenje one in no way feels they have entered a coal-mining region. With its measures to reduce and eliminate negative impacts on the environment, the company has long been actively involved in the programme of water, land and air remediation in the Šaleška Valley. After a mining process is completed, Premogovnik organises remediation and recultivation of degraded areas. By carrying out a number of projects and activities, it aims to restore a friendly feel in the environment. With the primary goal to strive for a healthy working and living environment, Premogovnik Velenje has a significant impact both on ensuring a healthy life in the Šaleška Valley and creating new jobs.

Ever since the end of the World War II, the company has given a lot of attention to modernisation and implementation of advanced technologies in coal mining that could reduce physical strain and provide miners with the greatest possible safety at work. One of the thickest lignite layers in the world has led to the development of innovative mining methods, based on the company's own engineering know-how and a systematic search for the most appropriate and safe mining method for thick coal layers. The beginnings of long walls go back to 1947, while the longwall mining method was first introduced after 1952. Today, it is known in reference books as the Velenje mining method, making Premogovnik Velenje into a household name outside Slovenia's borders. Through research, the method is constantly being developed and upgraded with technological improvements. Patent-protected, it is internationally acknowledged to be the most efficient sublevel caving method for excavating thick layers of coal.

Using the most advanced technology, Premogovnik Velenje produces excellent output, establishing itself as one of the best underground coal mines in Europe and worldwide. These results can only be achieved thanks to state-of-the-art electrical and mechanical equipment, the accomplishment of long-term development and the fruit of local engineering know-how. The company shares its knowledge and experience with markets in Asia-Pacific, India, Australia, New Zealand, Vietnam, Turkey, South East Europe, etc., thereby providing itself with plentiful new business opportunities.

# **Cities and Urban Environment**



# Dr. Strahinja Trpevski, F.Y.R.O.M.



## Challenges on the Path to Sustainable Construction for EU Candidate Countries

Chamber of Authorized Architects and Engineers of Macedonia

E-mail: [strahinja\\_trpevski@yahoo.co.uk](mailto:strahinja_trpevski@yahoo.co.uk)

### ABSTRACT

An integral part of our life is the environment that is created by building structures, contributing to the shaping of their own economy and development in general. The houses in which we live, the facilities where we work, water supply systems, electricity networks, roads, railways, airports, hotels, telecommunication networks are only part of the list of different buildings. For this reason, rationality in the construction industry significantly determines the effectiveness of many other industries and the economy as a whole. In turn, the effectiveness and readiness of construction work achieved significant levels in other areas such as economics, law, social welfare. Construction is an important part of every country's economy. Usually, it is firmly established sector is well adapted to local conditions which achieved the level of competitiveness comparable with the level of other sectors. Under the construction industry mean a number of economic activities that bring together and ultimately manifested in the construction of a building. It is a wide range which also includes the construction and production of construction materials and equipment. An important feature of construction is that binds much of the rest of the economy. A sustainable construction in small countries that have the ambition to enter the EU is a chain of activities in different areas that should be an integral part of the EU integration process as a whole and their sustainable development. The strategic approach to the sustainable construction activities identified in the long term development policy for construction activities is needed.

The strategic goals of that process that are the objectives of comprehensive analysis in this paper are; Legal and institutional framework as the backbone of sustainable construction; Technical regulations as the basis of the quality system in sustainable construction; Continuity of capital investment; Strengthening the competitiveness of construction firms; The formation of an adequate structure of labor for the sustainable construction and development of the industry of building materials based on the principles of sustainable development.

## 1. FOREWORD

An integral part of our life is the environment that is created by building structures, contributing to the shaping of their own economy and development in general. The houses in which we live, the facilities where we work, water supply systems, electricity networks, roads, railways, airports, hotels, telecommunication networks are only part of the list of different buildings. For this reason, rationality in the construction industry significantly determines the effectiveness of many other industries and the economy as a whole. In turn, the effectiveness and readiness of construction work achieved significant levels in other areas such as economics, law, social welfare.

Construction is an important part of every country's economy. Usually, it is a firmly established sector and well adapted to local conditions which achieved the level of competitiveness comparable with the level of other sectors. The construction industry means a number of economic activities that bring together different professions ultimately manifested in the construction of buildings. The wide range also includes the construction and production of construction materials and equipment. An important feature of construction is that it binds much of the rest of the economy.

### 1.1 Construction in the EU - market worth 1500 billions of Euro

The value of construction works executed in 2007 in the construction sector in 19 EU countries (members Euroconstruct network) is estimated at more than 1500 billion, which represents more than 12% of their GDP and less than GDP in Italy. The sub-sector housing construction had a dominant role, and represents almost half of the market with a share of 718 billion euros and is also the most dynamic component of the construction market. For new construction and renovation of nonresidential buildings 480 billion euros were invested, which represents almost one-third of the overall investment. Exclusively for the construction work 319 billion has been spent, representing 21% of the total value of construction projects in 2007.

Five major countries: Germany, Spain, Great Britain, Italy and France, occupying 72% of the entire construction in the EU, of which slightly more than 23% belong to Germany, which regardless of slowed economic growth in the past years, it still has a dominant position in the market in the field of construction.

Second place belongs to Spain, acquired in the year 2006 overtaking the place of Britain. A group of four countries in central-eastern regions of the EU accounts for less than 5% of the total European construction sector indicating significant nonlinear internal distribution in this sector.

Finally, we can say that the construction industry creates an enormous amount of waste material and building rubble from the demolition and reconstruction of old buildings (more than 270 million tons per year at EU level). Also, 42% of energy consumption in the EU belongs to buildings, with an expected growth rate of 1.5% per year for the next decade. This sector is the second one in contribution of CO<sub>2</sub> emissions. In some EU countries the lack of natural building materials is a significant problem.

## 2. A FRAMEWORK FOR SUSTAINABLE CONSTRUCTION

Sustainable construction should be committed to the "triple bottom line" concept, which asserts that long-term and sustainable progress requires the balanced achievement of economic development, environmental performance and social advancement. Based on this concept and to make sustainable construction easier to understand and implement, we should start from the evaluation process that could be applied, through a set of five common general "targeted issues" for sustainable construction. They are used to serve as a basis for the evaluation and assessing of the projects on exemplary sustainable construction buildings.



## 2.1 Innovation and transferability

The project must demonstrate innovation at the forefront of sustainable construction. Breakthroughs and trend-setting approaches, irrespective of scale, must be transferable to a range of other applications.

Innovative concepts regarding design, integration of materials and products, structure, enclosure and building services should be applied together with outstanding approaches regarding construction technology and processes, operation and maintenance. Contributions to the disciplines of architecture, urban and landscape design, civil, urban and environmental engineering and other related fields pertaining to construction should be provided. Long-term monitoring to evaluate the fulfilment of the initial expectations and goals must be established with dissemination of knowledge (project documentation and communication, education and training).

Outstanding examples of sustainable construction should not only mark significant advancement, the innovative idea should be one that can be copied again and again, thus promising the greatest benefit at a global scale. Transferable ideas are those that are affordable, simple, and broadly applicable and than all this process leads towards the „progress“ of sustainability.

## 2.2 Ethical standards and social equity

The projects must adhere to the highest ethical standards and support social equity at all stages of construction, from planning and building processes to long-term impact on the fabric of that community. The project has to provide an advanced response in terms of ethical and social responsibility with participation of stakeholders (client, users, neighbourhood, local authorities, non-governmental organizations and others) and complete political transparency and correctness.

Especially in poor countries, sustainable construction means building to supply urgent and basic needs: shelter, water, schools, access to goods and services, and medical care. In other countries, affordable housing is a main issue. In still others, the problem is wasteful and excessive consumption, which might be financially affordable but is irresponsible. Leaving sufficient materials and resources for others, including future generations, is a moral duty.

Sustainability requires a built infrastructure that respond to the emotional and psychological needs of people by providing stimulating environments, raising awareness of important values, inspiring the human spirit, and bonding societies, communities, and neighbourhoods. Many sustainable construction projects are developed by teams using a collective approach through which stakeholders and users are included in the design process. The process requires the highly-principled treatment of people during the design, construction, use, and recycling of buildings. All this puts the “people” in the centre of focused activities.

## 2.3 Environmental quality and resource efficiency

The project must exhibit a sensible use and management of natural resources throughout its life cycle, including operation and maintenance. Long-term environmental concerns, whether pertaining to flows of material or energy, should be an integral part of the built structure. low environmental impacts over the project’s life cycle must exist. High ratio of renewable energy to fossil energy in construction, operation and maintenance should be applied.

A fundamental principle of sustainable development is to keep our planet in condition to indefinitely support future generations. This is an enormous challenge because our global ecosystem is in a state of stress and overuse. Finite sources of energy and materials are being depleted, and much of our environment is being polluted or spoiled.

The construction industry plays a great role here as a large consumer of materials and energy. At the building scale, sustainable construction aims to provide long-lasting, healthful, and useful buildings while conserving finite resources of materials and energy by using durable, recyclable, and renewable materials, through energy-efficient design, and by using environmentally neutral energy sources (wind, sun, geothermal, etc.) and mechanisms (shading, simple evaporation cooling, etc.).

At the urban and regional scales, sustainable construction involves planning that preserves environmental quality, conserves energy through efficient design, reduces waste and consumption through sensible design, and reduces pollution by establishing efficient transportation networks. At all scales, sustainable construction aims to support ecosystems through design with nature (establishing and improving habitats for wildlife, supporting biodiversity, replenishing groundwater instead of channelling rainwater into storm sewers, etc.).

## **2.4 Economic performance and compatibility**

The project must prove to be economically feasible and innovative as far as the deployment of financial resources is concerned. Funding must promote an economy of means and be compatible with the demands and constraints encountered throughout the construction's life span.

Through efficiency of design, construction, maintenance, operation, reuse, and recycling, sustainable construction seeks feasible projects that provide long-term economic benefits for owners, users, and communities. Such benefits can take many forms besides profits or lower costs, for example: strengthening the economic base of a region, boosting the local economy, giving residents more control over their housing costs, or even giving people a financial base.

Innovative deployment of financial resources, durability, adaptability, lifecycle cost planning, "free" low-tech natural resources, and other attributes can work together to make sustainable construction not only financially feasible but the preferred choice and a sound long-term investment in the future.

## **2.5 Contextual and aesthetic impact**

The project must convey a high standard of architectural quality in the way it addresses cultural and physical factors. With space and form of utmost significance, the construction must have a lasting aesthetic impact on its surrounding environment.

Design quality is the aspect that clearly distinguishes sustainable construction from other forms of sustainable development. Visual expression and fitness of form are two essential qualities of all good architecture and planning, and these are also central to sustainable construction. This applies at all scales: land use planning, urban planning, and architectural design.

Land use planning should preserve natural areas and the inherent qualities of the landscape. Besides providing an efficient and functional infrastructure, urban planning should create spaces and places of cultural significance and social value.

Urban redevelopment projects and large public projects should heal and upgrade neighbourhoods and city quarters. And architectural projects should not only meet the owner's requirements (program), but match the physical context (site and neighbourhood) and improve the local surroundings.

### 3. HOW TO ACHIEVE THE PATH TOWARDS SUSTAINABLE CONSTRUCTION IN THE EU CANDIDATE COUNTRIES

Construction is a sector with specific characteristics, which is strictly regulated and is entirely different from other sectors. It represents a heterogeneous and fragmented sector based on a large number of different professions. Also, it's a sector with the most striking regional differences where the aspect of logistics and transportation is very important.

End products in the construction industry is one of the few products that can not be transported, and is also one of the most persistent human artifacts in the area. Construction creates physical infrastructure for housing and work, for production, transport and essential services. In the developed world, half of construction projects relate to reconstruction.

Construction is closely linked to economic cycles, due to the fact that they are commonly performed in external conditions is dependent on the seasonal climate variations. In addition, the sector is labour intensive, with high labour mobility and the growing need for all types of qualified workforce as a result of the application of increasingly sophisticated construction technology.

When investing in machinery, tools, and other production elements, the amortization period is shorter than in other industrial sectors. Contracts are often related to the duration of the construction works and the level of accidents is relatively high.

The output of the construction industry, be it public buildings, commercial buildings, homes or infrastructure such as our roads, harbors and sea defenses, has a major impact on our ability to maintain a sustainable economy overall and has a major impact on our environment. Moreover, it is clear that we cannot meet our declared environmental targets without dramatically reducing the environmental impact of buildings and infrastructure construction; we have to change the way we design and build.

The **Sustainable Construction** is a joint industry and Government initiative intended to promote leadership and behavioral change, as well as delivering benefits to both the construction industry and the wider economy. It aims to realize the shared vision of sustainable construction by:

- Providing clarity to business on the Government's position by bringing together diverse regulations and initiatives relating to sustainability;
- Setting and committing to higher standards to help achieve sustainability in specific areas;
- Making specific commitments by industry and Government to take the sustainable construction agenda forward.

Today the world made a big step forward in terms of the quality of the built environment, but there are many open current issues of sustainable solutions and low energy consumption. This has highlighted the need to find new solutions in technology and construction for the introduction of new standards and regulations to protect the quality of the construction. Technological revolution, on whose threshold we are, follows the huge number of rules converted into the new regulations. From the point of accession to the European Union, this is a major challenge that must be given to the organized process of high intensity.

Because of all the above, we believe that the „seven strategic objectives“ defined and analyzed in the context of the current state of EU candidate countries as Macedonia is, can offer a complete and correct identification of all issues on which is to build a proper action for the development of sustainable construction.

### 3.1 First strategic objective

The First strategic objectives that undoubtedly has a direct impact on all the others, and that is: **Integration of the country into the EU and sustainable development**, which in turn imply the development of civil engineering as an integral part of the process of EU integration and sustainable development of the country. In general, this commitment not only stems from the fact that the strategic orientation of the economic policy of country is joining the system of European Union, but the new economic environment that is to be established, in which the construction industry needs to act in the immediate and wider environment.

### 3.2 The second strategic objective

The second strategic objective is : **Legal and institutional framework as a basis for the development of civil engineering**. It is indisputable that this is a starting point in a series of other actions that create an environment and prerequisites for all activities in the area, the safety of property and ownership, defines the procedures and criteria, and requirements through a well dimensioned and qualified institutional framework.

### 3.3 The third strategic objective

The third strategic objective is: **Technical regulations as the basis of quality systems in construction**. The system of construction quality in the construction industry based on technical regulations and standards, which among other things provides one important part and lighter and easier movement of services and materials in world trade. However, standardization involves the establishment of a basic institutional framework for monitoring and control of the process. In this segment should adopt Euro-codes that in the EU are obligatory for use and incorporate. Other European directives related to building materials, energy efficiency services, geotechnics, water and waste water, solid waste, FIDIC conditions of Contract and ISO standards for management should be implemented.

### 3.4 Fourth strategic objective

Fourth strategic objective should be: **The continuum of capital investment**. Specific objectives of macroeconomic policies are oriented towards the construction of infrastructure projects and animating interest of new investors in the country; encouraging entrepreneurship within small and medium enterprises, to strengthen the competitiveness of the economy and the realization of the equilibrate development. The realization of the particular objectives of macroeconomic policy is in close connection with activities in the fields of civil engineering and construction industries. They point to the importance of this activity and industry for the overall development of the country in the short, especially in the medium and long term. The exercise of the above individual goals of macroeconomic policies will have direct and indirect effects not only on the development of civil engineering and construction industry, but also to the development of the overall economy and employment.

### 3.5 The fifth strategic objectives

The fifth strategic objective is: **Strengthening the competitiveness of construction companies**. Globalization in all areas of human activity has brought new insights into the possible direction of the optimal development of their own economies. Small countries such as Macedonia needs to maximize all the human and material resources with a steady following and accepting the development achievements of science, practice and technology.

### 3.6 Sixth strategic objective

Six strategic objective is: **The formation of an adequate structure of the labor force in the construction sector.** Each national economy and its sustainable development depends in part on the quality of human resources. The quality of human resources is determined by the quality of the education system, investment in education and participation in education. Delays in the development of the education system and a lack of investment in human resources is becoming a limiting factor for long-term sustainable development of each country. By creating the concept of reforming the education system in the country, it is envisaged that it is based on finding the original strategy inspired by the positive traditions and heritage into which they can incorporate the new trends of modern society and positive solutions from developed education systems in Europe.

### 3.7 Seventh strategic objective

Seventh strategic objective is: **The development of industry of building materials based on the principles of sustainable development.** One of the main aggregates in construction are the building materials that all building contractors are using for the construction, maintenance, reconstruction, and other construction works. A prerequisite is to use the mineral resources and building products on sustainable way introducing reasonable degree of energy consumption and pollution of space in order to have the most efficiently use resources and introduce systems of recycling and reuse.

## 4. CONCLUSION

The seven strategic objectives in scope and scale are quite wide and have an uneven pace of changes and impacts in a given time period. Respecting all the divergence and number of influential sectors on the development of sustainable construction, it is inevitable to emphasize that if investments are representing the skeleton of construction, then it is certain that rules and regulations represent the foundation of sustainable construction. The key to success is certainly a reform-transformation in the field of cadastre, property rights and rules for buildings. To achieve improved whole life value through the promotion of best practice construction procurement and supply side integration, by encouraging the adoption of the Construction Commitments in both the public and private sectors and throughout the supply chain. The overall objective of good design is to ensure that buildings, infrastructure, public spaces and places are build able, fit for purpose, resource efficient, sustainable, resilient, adaptable and attractive. Good design is synonymous with sustainable construction.

Our aim is to achieve greater use of design quality assessment tools relevant to buildings, infrastructure, public spaces and places. Reducing total carbon dioxide (CO<sub>2</sub>) emissions by at least at 26% by 2020. Within this, Government should set out its policy that new homes will be zero carbon from 2016, and an ambition that new schools, public sector non-domestic buildings and other non-domestic buildings will be zero carbon from 2016, 2018 and 2019 respectively. Conservation and enhancement of biodiversity within and around construction sites should be considered throughout all stages of a development. The materials used in construction have the least environmental and social impact as is feasible both socially and economically. The Future Water vision is to reduce per capita consumption of water in the home through cost effective measures, to an average of 130 litres per person per day by 2030, or possibly even 120 litres per person per day depending on new technological developments and innovation. All this shows the complexity and challenge to reach the sustainable construction.

## REFERENCES

- Nexant et al (2003) – Energy Efficiency Strategy of Macedonia, USAID
- Prof Stojkov.T, 2004- The multifamily housing construction in Republic of Macedonia-State of the Art
- Karner Andreas, GEF Agency, 2005, – Support for the implementation of the EC Directive on energy performance in buildings in Macedonia
- Euroconstruct, June 2008
- Prof. Dr. Meri Cvetkovska and Dr. Strahinja Trpevski, 2009- Preparation of the national strategy for development of Construction of Montenegro by 2020
- Dr. Strahinja Trpevski and the team of experts, 2006, – Preparation of the national strategy for sustainable development of Macedonia by 2020
- Progress Report on the Strategy for Sustainable Construction- UK, 2008
- The Holcim Foundation for Sustainable Construction, 2012, – A framework for sustainable construction

# Robert Smodiš, Slovenia



## Sustainable multigenerational house as a response to global urbanization

Green Building Council Slovenia

E-mail: [robert.smodis@kema.si](mailto:robert.smodis@kema.si)

### ABSTRACT

A individual house in the context of tracking and compliance with the sustainability principles should in future fulfill the new functional as well as increasing international sustainable standards that would allow its residents enjoyment of economical, ecological and social values.

Restoration of the in the distant past already existing multigenerational cohabitation will become a necessity, or even the result of particular economic and social conditions, that are indicating today more and more obviously the problems of the generation split and individualization of living. A new multigenerational typology of living enables living synergies between generations in the frames of modern integrated sustainable architecture. Those buildings will be, besides everything due to their sustainable characteristics and purpose, serving its purpose for a long period, what will fulfill important requirements in terms of resource protection and minimum cost of the lifecycle of building structures and elements.

## SUSTAINABLE MULTIGENERATIONAL HOUSE AS A RESPONSE TO GLOBAL URBANIZATION

Changes associated with global urbanization trends are present and more than evident today, probably the consequences of this trend cannot be avoided even in the future. For some time, more than half of the world's population lives in cities and immigration is still continuing. Analysis and statistics show that in 2030 at least 60% of the world population will live in urban centers. The question that arises here is whether it is good or bad?

From the viewpoint of sustainable development of society and especially in terms of protecting the environment and reducing negative impact on the environment, we certainly could argue that, in this are more positive effects than those which present deterioration of conditions in this area. Dense population certainly delivers significant savings in the segment of protection of resources for the implementation and maintenance of infrastructure, the positive impact will be particularly great in the area of mobility. More efficient public transport, especially the reduction of private transport would be an enormous contribution to reducing greenhouse gas emissions. To put it simply, the cheapest public transport is the elevator. Types of buildings, which combine dwelling, work, education and leisure time have been well known for a long time and are nothing new. However, it is not to ignore the social consequences of such social living and coexistence of people in a relatively small space which such architectural scenarios bring with it. Society and social conditions represent one of the three pillars of sustainable development of society, which marked the way of people's dwelling and living throughout the development of the human race.

Modern technologies enable us today to work and communicate from almost every place on earth. The technology enables us creation and simulation of desired dwelling conditions in buildings independent of outer climate conditions. Knowledge and technology enables us more efficient use of renewable and non-renewable resources which has the consequence that the consumption of these is much bigger and faster. All this and much more also have a huge impact on the economic situation of the world's population. Industrialization of production processes, production of goods, supported by advertising, promotes the consumption of these. Consequences are visible and detectable on every step in form of deviation from sustainable values, which led the whole society through centuries to the stage of development that we see today.

All of the above represents a fundamental starting point for the creation of dwelling space in the future, where it will be necessary to consider sustainability criteria to ensure a decent living environment for all people in society. The global urbanization trend mainly causes economic consequences for individuals that are caused by the living and working in the cities. In the first place are the availability and accessibility of workplaces, then the lower costs associated with the arrival to and departure of the workplace which are key motivators for the migration of the population from rural to urban areas. This trend is especially evident among young people who move for the first time already during schooling and an understandable consequence of that is that they remain in the city. Rural areas are becoming more and more empty and the age structure of the population outside urban centers is extremely rapidly changing towards an aging population. This trend is possibly slightly less evident in the suburban settlements that are infrastructural well connected to the city area. Undoubtedly, the strong depopulation of rural areas is reflected in more remote places that do not make economic sense for daily trips to town and back.

In a period of the past 30 years has even been a trend when the population was moving from the city centers to the surrounding rural areas because of the more beautiful and people-friendly environment for living.

Beautiful surroundings, access to local sources of food, especially high quality of life have outweighed time and money that had to be spent for the daily driving to work and back. With the constant energy price increases, the tense economic conditions, which require more and more active work - working time, the



luxury of living outside urban centers is becoming more expensive and available to a minority of the population.

Despite all listed, we have to ask ourselves whether living and dwelling in the rural area as we know it today, is dead, or is it possible that by the knowledge and technology that we have today, the trend can be stopped or possibly turned in the other direction? Can adjusted architecture considering overall sustainable aspects of living and building, help to slow down the trend of population movements? A key role in this could play social values of the society that are at the moment slightly pushed to the side, but at the same time they represent the essence of our work and daily activities. Generally population is striving with its work at a young age and a younger period to secure a decent living throughout their lifetime, in which an important role plays the ensuring of economic security in old age. That this is not taken for granted today, despite current social types, is more than clear to an increasing number of young people. Working in a late age and uncertain social conditions in the future, present a challenge for the whole population and it's hard to find the right solutions for that. Perhaps we need to look back in the past and take some experience and solutions from there.

Many post-war generations were staring for independence. Almost 60 years this type has been the driving force behind many other sectors. Changes in the economic, social and energy field are forcing the younger generation to a more rational planning for the future. Many analyzes which also put Slovenia in the top of countries where young people live with their parents also at a higher age, confirm this trend. Unfortunately, this also applies to the field of family and progeny planning, including dwelling. "Hotel Mom" is becoming such an increasingly popular shelter, which brings a number of changes in society. Perhaps even positive.

Coexistence and intergenerational synergies will require many changes in the people themselves, these effects will be especially related to the construction and housing industry. The type of larger multigenerational family homes is becoming popular again, after it has practically disappeared from the environment. Way of coexistence of multiple generations, which has been characteristic predominantly in the rural area in the past centuries, could, regarding the continuation of the existing trend, fundamentally affect the architecture and design of family homes. The wider social solidarity appears to be withdrawing economic criteria and the type of collective social responsibility for the aged group, unable to care for themselves, seems to wane. The most prominent cause is certainly the aging of population and partly the increasing unemployment among the working population, significantly is also the decline in purchasing power. Economic development and growth, reach from time to time their peaks, but the periodically repeating economic crises is generally eliminating this.

Young people, despite their graduation, cannot find their first employment and on the other hand more and more young people, despite their employment, do not receive the necessary financial support to ensure their own living space. This is the reason why they remain in the housing of their parents. On the other side of the age pyramid is the generation that enjoys a well-deserved retirement and has good prospects to live to an older age. A large part of this generation is faced with the fact that they live relatively comfortably until the time when they will need more help from the surroundings. At that time, their incomes will be too small to ensure an independent age, therefore help and solidarity from younger people and the surroundings will be necessary. In the middle is the working population who has adult children, who get by financially well but has a long way to retirement as their years of work increase. It is unlikely, however, that their savings will be sufficient for the carefree enjoyment of the autumn of their lives. Help to children, as well as any care for the elderly parents is not easy for them because their jobs allow little free time, the current costs of living are generally disproportionately increasing regarding to payment.

If we return once again to the young people. Those who opt for a family sooner or later are confronted with the fact of the costs associated with the care and education of their children up to school age. The time, when grandparents took over this task has practically died out decades ago, with the urbanization of the population and with a job in a capitalist economy. Working age, which is over 55 years, does not allow

grandparents to take over the care and education of grandchildren. Child care units became for many young people an unattainable luxury.

So why return to the multigenerational cohabitation concept? The answer is more than obvious. That what drove the economy over the previous decade, in the desire for increased profits, while leading the society to the brink of social sustainability, will now become an instrument of the people in the direction of ensuring security and independence. Rationalization, exploring synergies and saving at every step is the somehow expected reflex or response of the society in economic hardship. Dwelling and providing living space represent a major part of expenditure of an individual. This is reflected in the form of expenditure on food, and even more evident on costs associated with space for living and energy for its operation. Savings and rationalization in this segment can represent a significant change in the economic picture of each individual. Multigenerational form of cohabitation allows huge savings and rationalization in both investment as well as the running costs for the living space. All this is complemented by social synergy effects.

More concretely, this means that a building volume, in which may reside more than one person is generally more efficient, both in terms of investment, as in terms of operation. However, the comfort to which we have become accustomed in the recent decades, requires energy, which in any form represents a non-negligible cost that is constantly rising.

Multi-dwelling buildings have been some kind of design, which has been shown in the energy point of view to be more effective. Unfortunately, most of these buildings do not encourage multi-generational cohabitation but are generally focused on the mono-functional operation. Recently are appearing solutions that in some way enable you work, child care and residence in the same building, but despite that, we cannot call it a multi-generational cohabitation. Within these conglomerates which will certainly be part of the solution to global urbanization, multi-generational cohabitation concept is not self-evident and is feasible only with customized floor plans and functional designs. Family and family connections have represented through the centuries the backbone of human development, while representing a counterweight to the individualization of society. Solutions within large building complexes that will enable closer co-existence of generations are not necessarily based on family ties, but would assure within the mass urban society, the needed sense of security and belonging.

A single family house has been for decades the symbol for independence and financial stability. Today it is not exactly a rare occurrence when maintenance of a single-family home becomes a too big financial burden which the owners do not hold out or are forced to give up the many other benefits and advantages, offered to them by the modern society. If we are trying to simulate the trend, which is now present in the future, it increasingly shows that a single family house will become a luxury object for a minority of the population. In contrast, a multigenerational house or building could be part of the solution, not only the economic part of the sustainable development of society, but offers even effective solutions for the ecological and very important social part. All the above mentioned problems of young people and families, as well as the situations faced by the older generation, could be mitigated by this, if not eliminated. Of course it won't work without adaptation and change in thought patterns, but the benefits would be multi-faceted.

The first significant change should happen already in the process of planning and investment in the building. If as the contracting authority so far mostly occurred one generation, in the new concept at least two generations should act together. This has a direct impact on project work and the requirements arising from the expected result, especially in terms of cohabitation. The quality and durability of the building, and at the same time the burden of financing the construction and operation, would thus be shared by several generations, which would assure financial institutions more safety and thus increase their willingness to finance such projects. As already mentioned, for young people with uncertain employment policies, today the almost insurmountable obstacle is to obtain funding for such projects. The investment in such a building

is an investment in ensuring safe age not just to one generation and at the same time reducing dependency on existing, very unreliable and uncertain social structures.

The new typology of buildings should take into account the individual requirements of generations that are visible both in the form of work activity, as well as in the form of spending free time. Sheer functional requirements by a designated age group may not be left out. Young, with small children need a differently designed space than the middle generation or the generation in retirement. Individual access, particularly adaptation of equipment and size, may significantly affect the successful concept of multigenerational cohabitation. Flexibility and adaptability as one of the main leads in this design, may not be absent. Of course such coexistence allows some spatial optimization, such as one laundry, one technical area or boiler room, possibly a place for recreation, sauna and the like, one room or small apartment for guests, etc. Not only savings in investment especially lower cost of operation, improved use of space and nevertheless a high standard can be a result of this.

Important, if not decisive advantages are offered at this kind of lifestyle and social organization in terms of the social quality of living. Help in child care, mutual help in the maintenance and restoration of the building, safe age even beyond the period when people can no longer care for themselves, are just a few benefits that can be expected. Such a way of life creates a sort of almost individual social systems within a family or a small group of like-minded people who are willing to give up individuality for the mentioned advantages. Benefits are at the end showing in the increased economic independence and security through the entire life. An important and significant part of this can also be mobility. Sharing means of transport and distribution of costs is hiding huge potentials of financial savings as well as reducing the negative environmental impacts caused by this industry, despite the increasingly clear and advanced technologies.

In times of global urbanization, can become the multigenerational individual house or home, which will be constructed and operated in accordance with the criteria of sustainable construction, one of the foundations of social sustainability for future generations, taking into account the achieved living standard, economic viability, and of course a large part of the individuality of today's society. This is not going to work without adaptation and sacrifice of a small part of independence in exchange for increased security through the major part of life of each individual. We have to realize that in recent decades changes happened, whose effects can be expected only in the age of the present young population and only the timely activation of existing resources may reduce the potential negative effects.

The described changes bring new opportunities and challenges in the architectural design of space in both independent living buildings, as well as in multi- housing or even multi-functional buildings. It will be necessary to find the right balance and the answers to the functional needs of different age groups in order to maximize synergy effects in terms of economic, ecological and social qualities, which represent the three key pillars of a sustainable society, development and construction with architecture.



# Prof. Janez Koželj, Slovenia



## City of Ljubljana on the Way to a Sustainable Future 2007–2011

Deputy Mayor of Ljubljana Municipality, professor  
at the Faculty of Architecture, University of Ljubljana

E-mail: [janez.kozelj@ljubljana.si](mailto:janez.kozelj@ljubljana.si)

### ABSTRACT

The recent urban development indicates some sustainable trends of inner city redevelopment as well as non-sustainable patterns of decentralization. Renewal of the historic city centre was carried out mainly by rearrangement of public spaces parallel to extending pedestrian zones to improve environmental conditions, generate the outdoor city life and encourage economic activity. The inner city development of mixed-use urban districts with housing, workplaces and the services along the public transport corridors was seen as the best way to reduce the urban sprawl; new mixed-use urban neighbourhoods have been developed during this period inside of the outer ring of Ljubljana, strictly on degraded areas. The start-up projects of shifting car-oriented mobility towards sustainable mobility include incentives to invite people to walk, bike or use public transport and to make the use of car less attractive.

This paper is the first report about the way the municipality of Ljubljana started to introduce the process toward more sustainable development of Ljubljana during last 5 years.

The planners consider the sustainable development mostly popular on declarative level, while acting or behaving in sustainable way is less popular. The sustainability is in general understood as a political concept of restrictions, regress and conservation. In the same sense, the values the sustainable development proclaims are opposite to values of consumerist, hedonistic and competitive society, the liberal capitalism is based on. Regarding conditions of democratic society it is hard to believe we could force the people to change their habits and lifestyles by reducing consumption of any sort without any promises or benefits of new sustainable paradigm.

Besides, the introduction of sustainable development seems to be very complex process that integrates different politics and programs of different institutions and different players on different levels.

The main political task is therefore, how to convince the people, stakeholders, opinion makers, to change their believes overnight. What is the acceptance of different publics for SD concept? How SD has to be promote in order to became peoples friendly prospective?

**For that reason our most important task, we are faced with, is how to explain to the people convincingly, what in fact the meaning of sustainable development is about. The actual crisis, we are confronting, offers a good opportunity to persuade them.**

## DEFINITION

We should try to replace the common perception of sacrificing and general resignation the people relate to SD with optimism and felling of common responsibility. As Thomas Randall claimed, sustainability is not about regression and conservatism, but about poetry, optimisms and delight, energy, meanwhile emissions, water and wastes are secondary. Another argument to this motivating explanation is that sustainable development is not an anti-growth ideology. It is very important to make a distinction between the growth and development: growth is quantitative, development qualitative concept, as H.E. Daly stated.

Sustainability has to be recognized as a concept of quality, which relates with improvement of live condition, including economic, social and cultural aspects, solidarity and social justice in distribution of resources. Sustainable development is the only alternative promise of better life.

We consider that sustainable development is convers to the process of globalization.

That means that the approach to sustainable development could vary from place to place and from time to time. Sustainable development policies has to be specific contextual and politically acceptable by local community. Furthermore, sustainable solutions should depend of the scale; only appropriate detail solutions strengthen the effect of strategic principles.

***These were the starting points we relied on to define our way of redirecting Ljubljana toward the more sustainable future.***

## POTENTIALS

*Ljubljana developed on the narrow passage between Ljubljana field and Ljubljana marsh flatland, where the woodland passed the city center. The city extends between two rivers giving good condition for underground water supply.*

*Ljubljana is a green city; more than 50% of municipal territory is green areas of agricultural land, marshes, woods, parks. Ljubljana is a twin city, half of its territory is urbanized, and another half is country. The city developed in a star-shaped urban form that offers the prospect for the development of high density urban corridors based on public transport spine, which is alternating with continuous landscape corridors in green wedges between the legs. Green corridors are providing a sense of continuity between city and country; they permit the movement of wildlife within the city.*

## TRANSITION

*After the independency of Slovenia during last 15 years Ljubljana passed over the transition from post-socialist city toward the free-market oriented city. The consequences of uncontrolled development included projects of strategic importance which remained unrealized.*

*The city center gradually decayed while the suburbs developed more or less spontaneously. The power of the public sector has been waning, and that of the private has been increasing. The feeling of collective impotence was heightened by the various conflicts of interests, which resulted in deadlock with no apparent solution in sight. Like everywhere else in the world, Ljubljana has decentralized rapidly. The free-market city has been reorganized around new centers of mostly commercial development. The core city has been transformed into a regional city where new forms of decentralized centralization are springing up in hubs.*

*The new legislations for the different economic sectors have been put in place and the major changes in the ownership relations by privatization and restitution have also been completed. After that, new driving forces and supporting instruments for more efficient urban management were activated.*

## STRATEGY

While preparing new long term plans we decided to apply very simple strategy by:

- putting a clear vision in our plans;
- using municipal planning powers as the developmental instrument;
- acting flexible toward realistic goals
- starting sustainable development projects without hesitation.

We took into account that sustainability is a gradually process of continuous improvement so community constantly evolve and take changes to accomplish its goals. In this sense we applied experiences from different European cities that had traced their path toward sustainable development before us. The most significant for implementation of sustainable politics were:

- the definition of operational principles of sustainability,
- the creation of a collective city vision,
- clear, measurable goals
- early, visible results.

In this prospective the city vision, we created in 2007, indicated:

- how Ljubljana will look like in 2025,
- what role will the city play in the Central Europe, country and region,
- what kind of changes Ljubljana intent to go through in order to follow more sustainable development.

In proceeding adopted general plan tries to put in force guidelines for inner city redevelopment, dispersed concentration of suburbs and renewal of countryside. The new plan brought in force a set of operative tactics for sustainable development which could be strictly implemented and easy controlled:

**They are related to:**

1. Inner city renewal and sustainable mobility,
2. Brownfield re- development and reclamation o derelict land
3. Temporary transitive use of left over abandoned land
4. New urban development along public transport lines
5. Compacting of dispersed development in periphery and outskirts
6. Energy renewal of large residential estates
7. Extension of greenways and greenbelts, saving wetlands and urban forests.
8. Urban gardening.

**REDIRECTING TRENDS**

During the last 5 years the new city government was striving to activate new developmental instruments to set in motion the unexploited potentials of the city and its region. A more pro-active public leadership in intense cooperation with the private actors led to a more balanced, controlled market development of the post-socialist city. The recent urban development indicates sustainable trends of inner city redevelopment as well as non-sustainable patterns of decentralization. The process we started was oriented at revitalization of the historic city center mainly by rearrangement of public spaces parallel to extending pedestrian zones, which then generate new social and economic activity. Inner city development of mixed-use urban districts with housing, workplaces and the services was seen as the best way to reduce the urban sprawl. New mixed-use neighborhoods have been built inside the outer ring of Ljubljana, strictly on degraded areas of abandoned industrial land. The strategy of shifting car-oriented mobility towards sustainable mobility includes preparing incentives to invite people to walk, bike or use public transport and to make the use of car less attractive. The projects and measures the city has initiate carried out based on believe that sustainability is a long term process of continuous improvement so communities constantly evolve and take changes to accomplish their goals.

**STARTING SUSTAINABLE URBAN DESIGN**

Since by definition, the sustainable urban design is about the appropriate balance between development and conservation relating directly public health and welfare, we made the decision to give the priority to the inner city re-development projects. Determination to start renovating city center according to the sustainable development principle places priority on the restructuring and reuse of the built land, buildings and infrastructure. With the aim to demonstrate to the community the sustainability as a concept of quality, we initiated the projects of rearrangement of public spaces which represented a sustainable objective which we were capable to work toward. Therefore, we gave priority to those urban design projects that affected immediate and strong change of quality of public life in the city center, encouraging local economy, local services and facilities.

Parallel to urban design and infrastructural projects we introduced traffic reform by reduction of motorized traffic in favor of walking and bicycling or using public transport to make the use of car less attractive.

The new approach to transport problems is based on the following assumptions:

- There is a direct link between the quality of public life in the city and areas closed to moving and stationary motor vehicle traffic.
- Walking is the only truly natural mode of movement in the city. Furthermore, it promotes urban living in public spaces, squares, streets, parks and banks.
- Road and road network expansions further increase and attract inbound motor vehicle traffic in the city.
- People prefer not to drive into the cities where there are no parking possibilities.



- An efficient and comfortable public transport should replace rather than merely complement car journeys.
- Only if freight trans-shipment and delivery are differently organized, the number and duration of delivery and cargo vehicle journeys within the city will be reduced.
- The city transport policy ought to promote walking and cycling in combination with different types of public transport.

The direct and indirect impacts of recently re-arranged public's spaces are promising. Communal infrastructure investments and pedestrianisation of public spaces activate the economic and social regeneration of the historic town center.

Limited or eliminated motor traffic makes public spaces more attractive, comfortable and safer. Renewal of historic pavements and street furniture reinforces the spirit of place. Renovation of river banks extends the public space and improves access to the water element. Renewal of avenues and parks meet new needs of the people.

Flexible public transport on demand within car-free pedestrian areas provides good access to all people. New arrangement of reconquered public domain extends the continuous pedestrian area. New public green spaces improve the local climate and environmental conditions within the old city. New footbridges enlarge the network of footpaths and cycle lanes. New arranged public spaces extend the use and stimulate the outdoor city life on the streets and squares. New arranged public spaces attract new visitors and new residents into city center.

**After start-up projects have been realized, we believe the more complex sustainable development plans to be realized in upcoming years to 2020.**

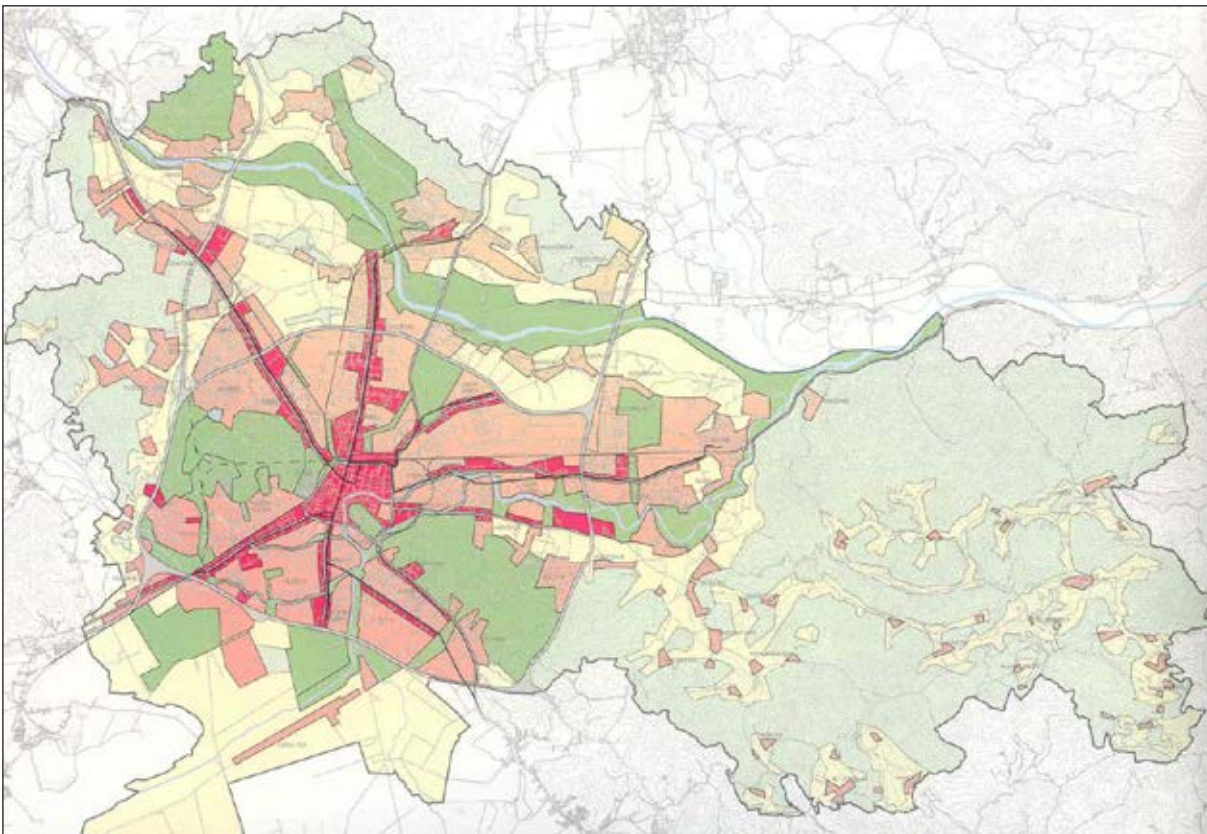

LJUBLJANA – MASTER PLAN

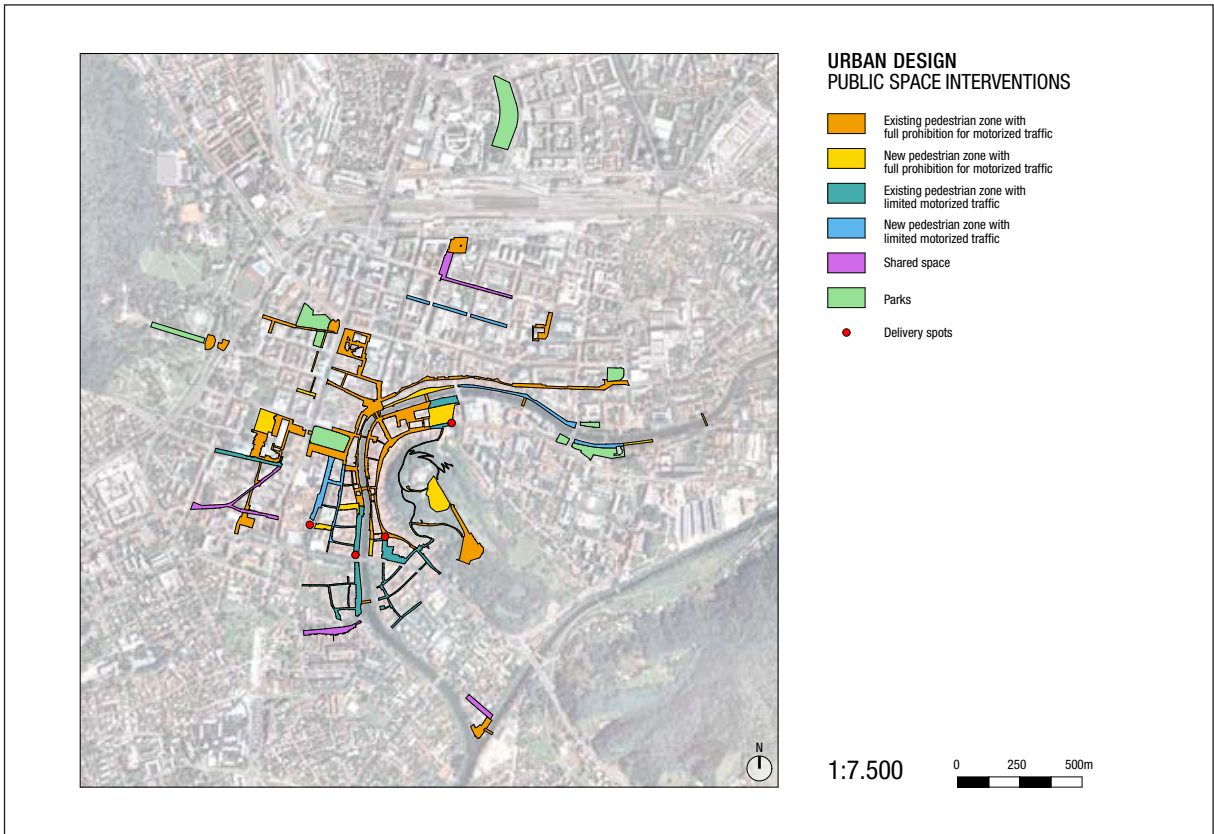

URBAN DESIGN – PUBLIC SPACE INTERVENTIONS

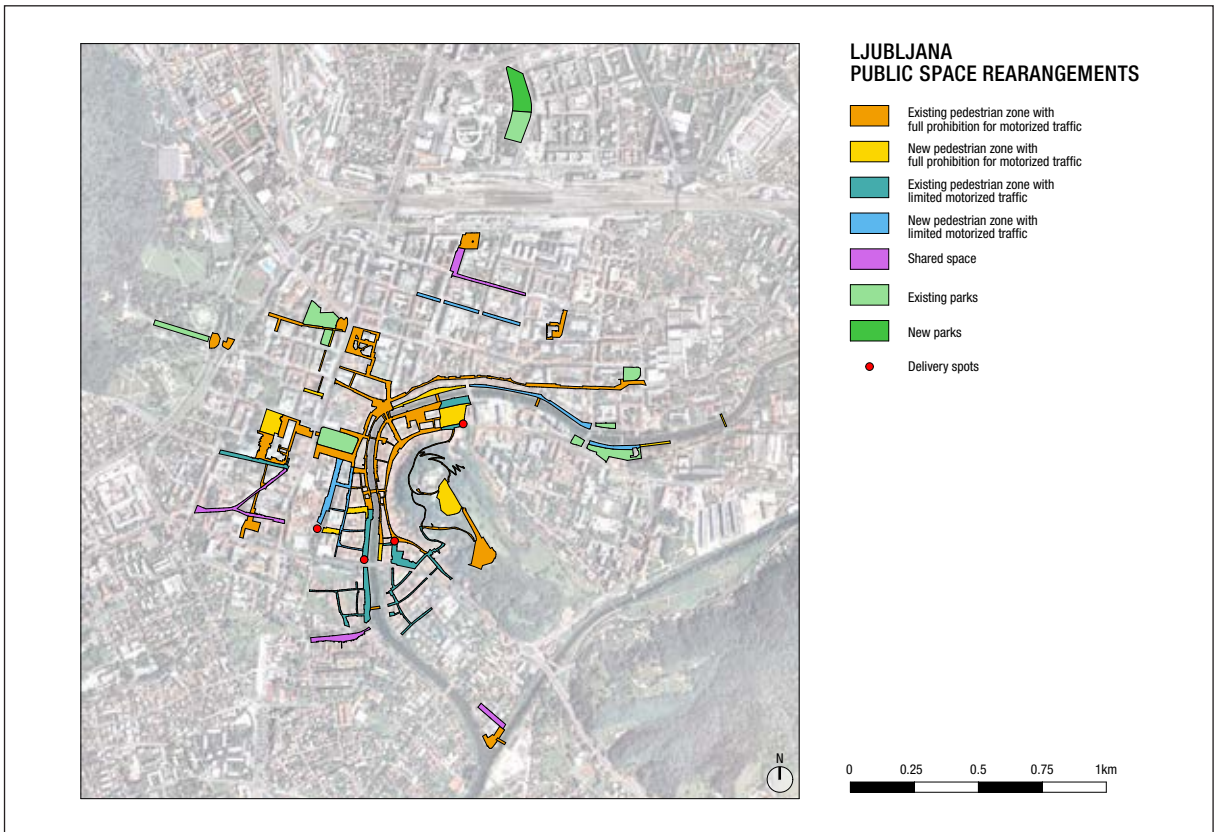

LJUBLJANA – PUBLIC SPACE REARRANGEMENTS



LJUBLJANA – BROWNFIELD REDEVELOPMENT

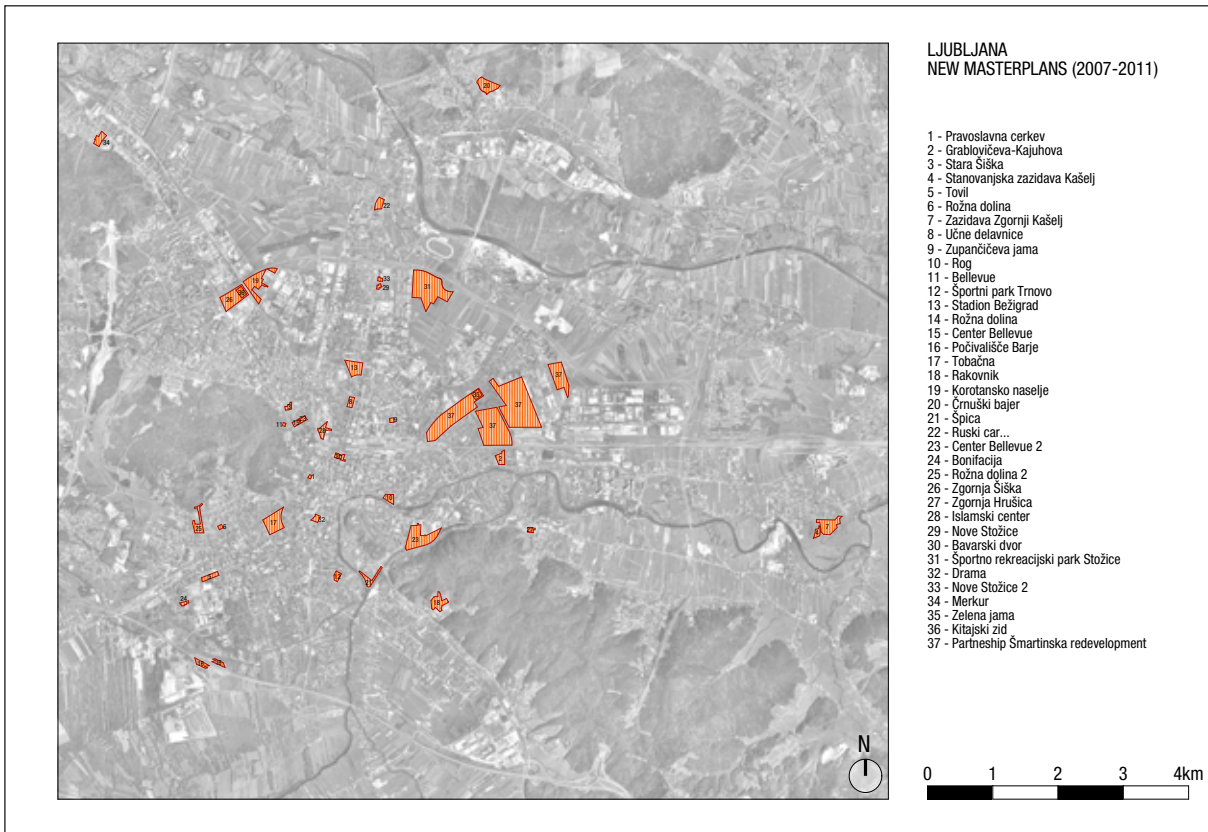

LJUBLJANA – NEW MASTERPLANS (2007-2011)

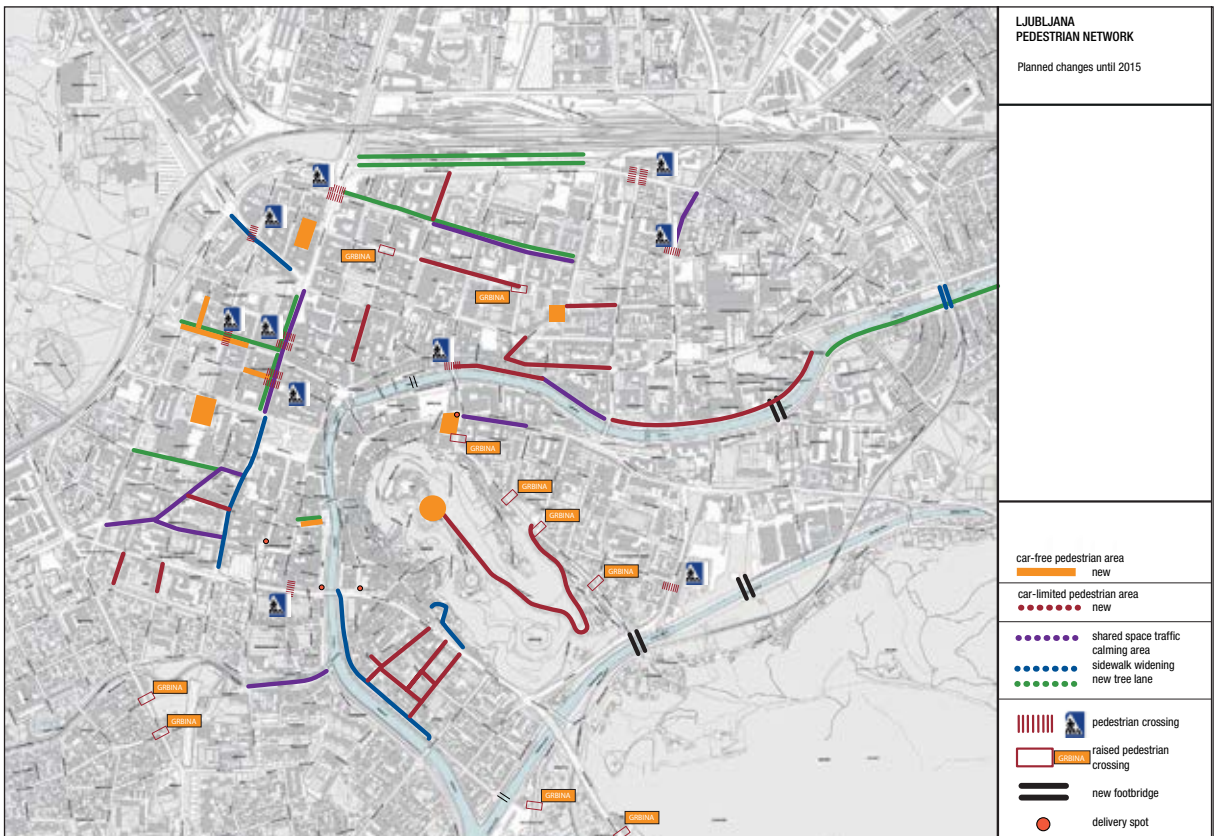

LJUBLJANA – PEDESTRIAN NETWORK

Planned changes until 2015

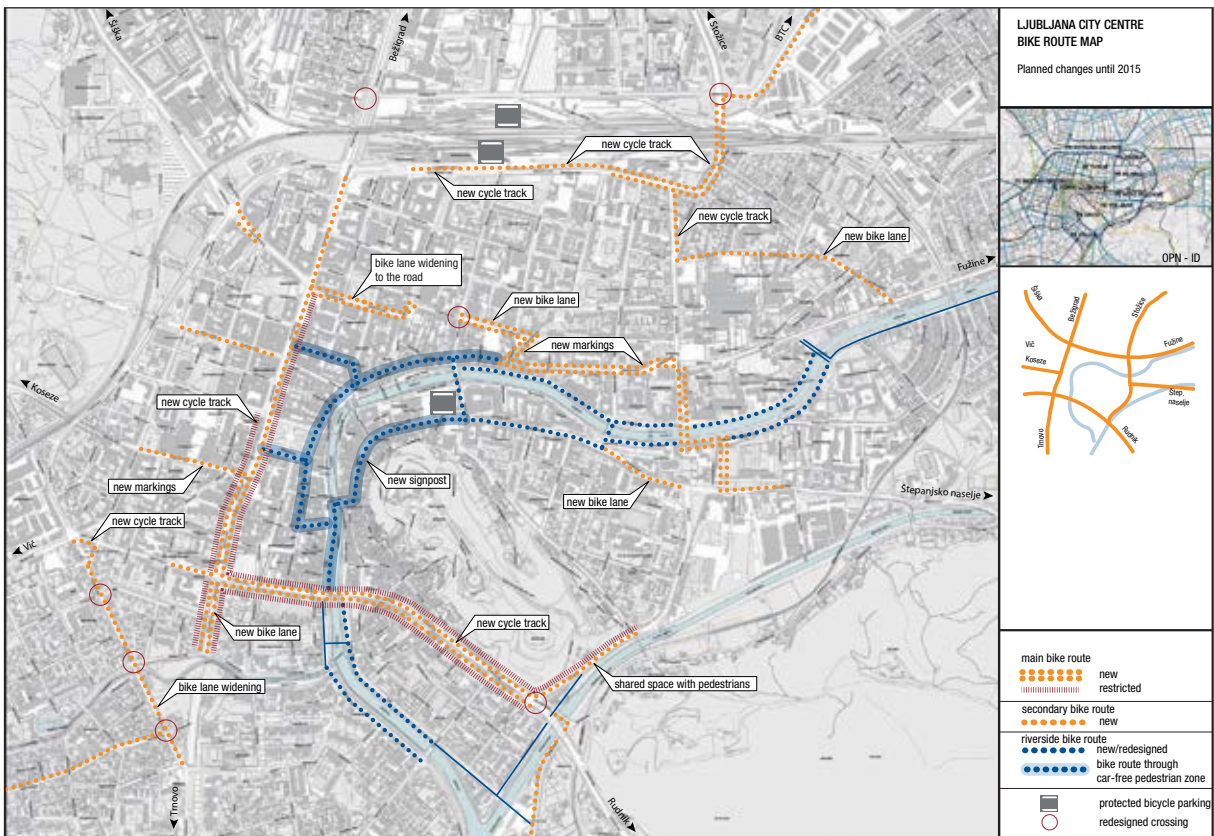

LJUBLJANA CITY CENTRE – BIKE ROUTE MAP

Planned changes until 2015

# Er. Seng Chuan Tan, Singapore M L Fam, T W Lee and S C Tan



37

SENG CHUAN TAN

## A Singapore Story: From Concrete Jungle to Liveable City

Institution of Engineers Singapore

E-mail: [SengChuan.Tan@ch2m.com](mailto:SengChuan.Tan@ch2m.com)

### ABSTRACT

“Cities and the Urban Environment” often conjure images of awkward concrete jungles. In this article, we will present the development of Singapore from a concrete jungle to a liveable city. In the recent 2011 Monocle survey, Singapore ranks as the 15th most liveable city in the world (Leong, 2011). The consideration in the assessment includes efficient government, growth in economy, education level, medical services, crime rate, efficiency on the infrastructure etc. This reflects the concept of economy competitiveness, good governance, integrated planning, environmental sustainability, and the quality of life. Since independence in 1965, Singapore has intricately balanced economic development with maintaining herself as a habitable location. In 2010, Quality of Living Survey revealed that Singapore ranked 1st in Asia for offering the best quality of life (Mercer, 2012). While looking ahead to the future and building a liveable city, Singapore continues the journey in developing the blueprint of sustainability involving four main strategies – boosting resource efficiency, enhancing the urban environment, building the capabilities of green technology and fostering community action. The paper will examine case studies on Singapore’s experiences turning into a liveable city.

## INTRODUCTION

Singapore is a small country having a land area of 714.3 km<sup>2</sup> with a combination of unfavourable factors, such as a lack of natural resources and space. Singapore has to manage economic development through its urban master planning by not compromising the quality of the living environment and sustainable development.

After the basic infrastructures were gradually taken care of, more emphasis was placed on improving the general quality of life. The Housing Development Board (HDB) continued to promote public housing with new towns and new residential estates having higher-quality apartments that are served with better amenities. In 1987, the first public train system, the Mass Rapid Transit (MRT) line began operation, connecting most of these housing estates to the city centre.

The city has continued to grow, and now has about 5.2 million residents, making Singapore one of the densest places in the world at 7,257 people per km<sup>2</sup>. In order to adapt to growing resources restraints and continue to develop a better living environment, the government has introduced four strategies - boosting resource efficiency, enhancing the urban environment, building the green technology capabilities and fostering community action, to guide this development.

Boosting resource efficiency is crucial as Singapore imports most of its resources and has to maximise it, thus this is applied in the context of water, transportation and waste management. Enhancing the urban environment is pertinent to improving the quality of life of people, and involves integrating the eco-system in the city environment, promoting building performance and creating new parks. Building up green technology capabilities is anchored on looking at a diversified portfolio of energy resources, and assimilating the various technologies to Singapore's context. This involves setting up a research ecosystem, and the facilitation of test-bedding of technology. To hold the three strategies together, community support is fostered from a rapport group of business leaders, non-government organisations and residents in the community. Policies are tailored to industries, and empowerment of the individuals of the various groups are managed through education curriculum and community programmes. These four strategies will then guide and shape the liveability of the Singapore City taking into consideration of long-term integrated planning, cost-effectiveness, flexibility and implementation.

### 1. BOOSTING RESOURCE EFFICIENCY

The first strategy towards enhancing liveability is focused on basic infrastructure. The strategy is for improving resource efficiency in the context of water, transportation and waste management. Singapore continues to face a strategic water challenge and this has driven the development of water reuse in 2003 as a key source of water supply. Desalinated water is subsequently introduced as another water source. The transportation infrastructure is being revamped to sustain a higher population density, while reducing emissions from the higher vehicle population. Waste management is introduced to value-add the high amount of waste generated, through creating energy from incineration plants and creating land from incinerated waste.

#### a. Water

The current four national water taps namely, local catchment, imported water, desalinated water, and recycled water – forms the basis for improving long-term water sustainability. In order to increase the resilience of Singapore's water supply, Singapore's national water agency PUB has developed a multiple prong approach. The Deep Tunnel Sewage System (DTSS) currently conveys and consolidates sewage from the central and eastern parts of Singapore to the large centralized Changi Water Reclamation Plant (CWRP), which also treats the water further to high-grade water namely NEWater. NEWater is supplied primarily to industry and currently accounts for 30% of Singapore's water demand, with a target of 50% by 2030. There

will also be 2 desalination plants supplying about 100 mgd of water by 2013. To maximize Singapore's ability to capture all available storm water, PUB has built the Marina Barrage which created the Marina Reservoir within the city, collecting urban runoff for water supply purposes. The barrage also acts as a tidal barrier, offering flood protection. Two-thirds of Singapore is now catchment areas and PUB is developing the technology to increase this to 90% through Variable Salinity Plants to treat fresh and brackish waters

### **b. Transportation**

The growth of Singapore's public transportation system has also seen significant development under the Land Transport Authority (LTA). Two of the key components of LTA's land transport strategy include enhancing the integration of the public transport network, which includes both buses and rail, and expanding the rail network. The planning of bus routes and feeder services will be centralized to integrate closely with the road and rail infrastructure, and more integrated transportation hubs will be developed. There will also be an increased focus on enhancing the rail network by doubling the network to 278km by 2020, achieving a rail density of 51km per million persons and hence greater overall connectivity.

Within the private transport sector, vehicle owners are encouraged to switch to more fuel-efficient vehicles. Since April 2009, the National Environment Agency of Singapore (NEA) introduced the Fuel Economy Labelling Scheme (FELS) to empower consumers to make fuel-efficient vehicle purchases. Singapore has adopted the Euro IV emission standards for diesel vehicles and emission regulations have also been reviewed so as to achieve the target of lowering PM<sub>2.5</sub> level from 16µg/m<sup>3</sup> in 2008 to 12µg/m<sup>3</sup> in 2020. Since October 2006, all new diesel vehicles comply with the Euro IV emission standards.

### **c. Waste Management**

Singapore has implemented an integrated waste management system that collects and disposes of waste effectively. Refuse is collected daily, and incinerated in waste-to-energy plants; this allows the reduction of land needed for landfill and the ability to meet 2 to 3 % of Singapore's electricity needs. In order to maximise the usability of waste, ash from the incineration plant as well as non-incinerable waste like construction debris is used for offshore landfill. This landfill, named Semakau landfill, is expected to last another 40 years, and will become part of land stock of Singapore. Conservation efforts were made to preserve the flora and fauna, and in April 2007, Semakau landfill was lauded in *New Scientist* that is it the "Garbage of Eden" (Bland, 2007) – showcasing an example of environmentally friendly system of waste management.

To reduce the need for incineration and landfill, the National Recycling Programme was launched, where centralised recycling bins and door-to-door collection of recyclables every fortnight in public housing and private landed housing estates. The National Environment Agency (NEA) has also launched a voluntary Singapore Packaging Agreement to reduce packaging waste, starting with the food and beverage industry. The government thus aims to reduce the amount of waste entering the landfill, through policies targeted at the public and the industry, while the landfill puts together urban development in harmony with nature, with rubbish alongside thriving coral reefs, vast mangrove plantations and rare bird species.

## **2. ENHANCING THE URBAN ENVIRONMENT**

The second strategy of enhancing the urban environment is introduced in the form of integrated eco-systems in the city environment, promoting sky-rise greenery, and the creation of new parks. As Singapore becomes increasingly built up, the built environment will be enhanced with a sense of space and greenery, such as the creation of new vertical parks, parks connectors and new leisure options. The integration of an eco-system in the city environment takes place by forming a blue network through reservoirs, rivers and canals with the urban living environment. Through these variety of residential and commercial developments, Singaporeans live, work and play.

### **a. Integrated Eco-System in the City Environment**

The Active, Beautiful, Clean Waters (ABC Waters) programme aims to transform Singapore's water bodies which are now concrete drains and functional reservoirs used for the drainage and storage of water, into beautiful rivers with flowing water and lush landscapes. The goal is to integrate traditional engineering, landscape architecture, and ecology, and create a paradigm shift in the usage of storm water channels as a backyard functional drain into recreational space with thriving biodiversity amidst the lush landscape. In the Kallang River-Bishan Park project, the existing straight-edge concrete canal was restored into a natural river that meanders in the park and integrates land and water boundaries. A series of existing ponds were also designed to act as wetlands to improve the quality of stormwater, which will in turn be used in a new children's water playground. This effectively integrates the stormwater system completely into land developments to create a new experience for the community while maintaining the hydraulic function of the stormwater system. Social interaction niches for communities, cultural spaces, and opportunities for development facing the river are also created in the process, bringing people closer to the water ways and inspiring to keep them clean.

### **b. Promoting Building Performance**

Singapore is densely developed with low, medium to high-rise buildings in order to maximize land utilization. While this trend is expected to intensify with new ways of maximizing space utilization, it is recognized that increasing the energy efficiency and sky-rise green density of these buildings is key to creating liveable environments. Buildings contribute to 16% of Singapore's total energy consumption and energy cost constitutes 20 – 40% of the total operating cost for a typical building. The Building Construction Authority (BCA) established a \$20 million Green Mark Incentive Scheme (New Buildings) in 2006, and new buildings in key development areas need to achieve higher Green Mark ratings (Platinum and Gold) as part of its land sale requirements. Buildings with Green Mark features include double-glazed facade glass to minimise heat gain, and computerized brightness control for energy-saving lighting. Also, with the goal to increase greenery in high-rise buildings to 50ha by 2030, the National Parks Board (NParks) and BCA are working together to achieve this by encouraging developers to adopt building greenery. This is done through technology transfer workshops and design guides, community garden programmes, as well as accreditation through the BCA's Green Mark certification. The government will incentivise the development of sky-rise greenery in strategic locations in the city, with NParks piloting a grant scheme to co-fund up to half the installation cost for green roofs, focusing on the Central Business District. The URA will adopt a landscape replacement policy to introduce greenery into new developments, in which such developments need to provide landscape areas equivalent to the overall development site area in the form of sky-rise greenery and ground level communal landscape areas.

### **c. Creation of New Parks**

Singapore has also made significant efforts to ensure that there is a good balance between developing high-rise commercial and residential spaces and maintaining its green spaces and parks. Other than the main Botanical Garden which occupies 74 ha, there are also numerous neighbourhood parks located near every major township and other green pockets within the townships. The long term goal is to achieve 0.8ha of green space for every 1000 persons. The most recent park development is located along the waterfront of the newly created Marina Reservoir and Marina Bay. The Gardens by the Bay spans about 101 hectares and is an integral part of a strategy by the Singapore government to transform Singapore from a 'Garden City' to a 'City in a Garden'. Away from the city centre, there is also the Punggol Promenade – a 17km waterfront promenade that takes residents from a growing sub-urban hub along 2 rivers and a coastal stretch. Throughout the rest of the island, the NParks has also been expanding a Park Connector Network (PCN) which mainly runs alongside Singapore's many canals and rivers. The PCN aims to connect up parks, recreational spaces and residential areas to enhance access to these developments. There are currently more than 100km of park connectors and NParks aims to expand this to more than 200km by 2015.



### 3. BUILDING UP CAPABILITIES

The third strategy involves building up the capabilities in green technology. As the need to seek diversified energy resources becomes imperative, Singapore positions herself to be a vibrant research ecosystem, and a facilitator of test-bedding of new green technology. By doing so, it allows the assimilation of such technologies to suit our needs, such as in understanding the technical and maintenance issues involved in installation and the further development of these newly introduced technologies which will then allow Singapore to assist in advancing sustainable development in the region and beyond.

#### a. Creating a vibrant research ecosystem

In creating a vibrant research ecosystem, the Economic Development Board (EDB) of Singapore does so by incorporating world-class R&D centres, equipment companies, supplier base, testing and certification services, funds and incubator projects into this ecosystem. The research centres also provide training of specialised manpower, technical expertise to the local industry as well as scholarship programmes and a visiting professor programme. The Solar Energy Research Institute of Singapore (SERIS), Singapore's national laboratory for innovative solar energy research, was set up in April 2007 as part of the National University of Singapore. The vibrant ecosystem is created by bringing together complimentary service chains of the industry, such as equipment companies, incubator projects, and relevant skilled manpower for an overall seamless research ecosystem.

#### b. Facilitator of test-bedding

In line with being a facilitator of test-bedding of new technologies, a CleanTech Park is jointly developed by EDB, and Jurong Town Corporation (JTC), which is Singapore's principal developer and manager of industrial estates and their related facilities. This Jalan Bahar CleanTech Park allows companies to undertake clean technology activities such as R&D, test-bedding, prototyping and light manufacturing. The park, apart from providing a plug-and-play environment to facilitate test-bedding of urban solutions, also showcase sustainable building and infrastructure features. Alongside the CleanTech Park for test-bedding of technologies, the HDB has embarked on the first 'eco-precinct' project called Treelodge@Punggol in 2007, consisting of seven 16-storey blocks with test-bedding of solar panels to power common area lighting and rainwater collection for washing of common areas. The dense population of Singapore, together with a strong regulatory framework, makes Singapore an ideal living lab of sustainable development.

### 4. FOSTERING COMMUNITY SUPPORT

To seamlessly hold the first three strategies together would require support from the community - hence, the fourth strategy involves the fostering of support from the community. This rapport group consists of business leaders, non-governmental organisations and residents in the community. Schools also play a role in promoting environmental education, as campuses will serve as an education platform for students to learn and experiment with green technology. The industry sector is also empowered to judiciously utilise resources through grants and assistance schemes, while consumers are motivated to make resource-smart choices through energy efficient labelling on household products. The leaders and activists in the people, private and public sectors can work together to make environmental sustainability part of the Singapore culture.

#### a. Private sector

In the private and industrial sector, companies are encouraged to adopt more energy efficient processes. NEA has established an Energy Efficiency Improvement Assistance Scheme (EASe) to co-fund costs of energy audits by up to 50%, to encourage companies to study their energy consumption. Following that, NEA's Grant for Energy Efficient Technologies (GREET) schedule helps companies to offset part of the cost of implementing energy efficiency measures. Companies whose capital expenditure that results in greater efficiency can also tap on Investment Allowance (IA). As of 2010, a total of \$5.87 million had been approved

for the 205 energy studies under GREET. To lead by example, the Singapore government also introduces a Cogen power plant to reach energy efficiency for the industrial sector. Currently, such technology is utilised by multi-utilities service providers (MUSP) on Jurong Island and by companies in Tuas, with the possible extension of the MUSP model to other industry sectors and geographical areas within Singapore. Companies benefit from the lower price of utilities as well as the ability to outsource non-core functions to the MUSP.

### **b. Public sector**

In the public sector, environmental education is made part of the school curriculum. The Ministry of Education (MOE) has incorporated environmental topics such as recycling, energy and water conservation into the formal curriculum of the school subjects, such as geography, social studies and science. A network of Environmental Education Advisors has been established within schools to act as a key point of contact and to promote better communication between teachers and NEA. More than 2000 student Environment Champions are appointed to act as role models to assist their teachers in implementing school-wide and community initiatives. Currently, NEA has more than 200 youths trained as Youth Environment Envoy (YEE). The Non-Governmental Organisations (NGOs) also engage the public sector in resource conservation, public cleanliness and nature conservation. The Non-Governmental Organisations are assisted by the \$1.5million 3P Partnership Fund that helps them to spearhead new initiatives. The Nature Society Singapore (NSS) organises free nature walks and "show-and-tell" sessions for younger children, to promote nature education and ecological care of a local waterway. The Waterways Watch Society patrols the waters and removes any litter found in the waterways. The public sector will also take the lead by requiring new public sector buildings with more than 5000 m<sup>2</sup> air-conditioned floor area to achieve BCA's Green Mark Platinum rating.

### **c. People sector**

At the community level, the Community Development Councils (CDC) actively encourages residents to get involved in their community and to care for the environment. The CDCs take turn to co-organise the annual launch of the Clean and Green Singapore programme with the NEA. In support of achieving sustainability, the five CDCs have each developed plans, in partnership with their local grassroots organisations – for example, the South West CDC developed the ECo Plan, which envisions reaching out to 220,000 households to achieve 5 Eco goals – (i) reduce energy consumption for 80,000 households by changing to energy efficient light bulbs; (ii) appreciate nature by planting 1 million native plants, (iii) maintain public health and a clean environment by engaging and training volunteers from 20 schools to assess the cleanliness of public toilets, (iv) recognise individuals who display graciousness and kindness in the community through awards, and (v) facilitate active citizenry by recruiting an annual target of 1,600 Junior Environment Ambassadors to champion environmental and public health issues in the community

## **CONCLUSION**

As cities grow, they inevitably have to manage the demands that rise with the population growth, as well as the increasing strain on scarce resources.

Singapore's approach to achieving sustainable development is primarily focused on the use of technology to overcome physical constraints, and an example of that being the DTSS and the NEWater programme that unlocks a sustainable new 'tap' for overall water supply. An equally important strategy is to create a fertile environment for urban enhancement that improves liveability, through the use of policies that include instruments such as grants to temper and soften short-term costs to implement the enhancement features. The third prong of the overall approach recognizes that the implementation of technology and policies require stakeholder input and participation, as well as support by the community at large. This is in fact one of the most critical components of the overall approach because the effectiveness of the best technologies and policies often hinges upon the response of industry, the community and other key stakeholders. Finally, as the challenge of growing resource constraints continues to evolve, it is imperative for cities to look to the

future, push the boundaries and develop innovation and new technology capabilities to respond to new challenges. One of the most critical issues of the future lie in creating new energy sources; thus research and test-bedding in the Singapore context allows for potential assimilation of these new technologies.

Sustainable development involves a holistic approach from top-down policies initiated by the government to ground-up support from the people and industry that will carry these policies out. The sustainability development plan is given equal priority to other portfolios like economic development, as sustainable development is the key driver of continued city growth – simply due to the anticipated increased competition for land, energy and water. Through these strategies, Singapore puts itself on a sustainable path to manage the demands of a growing city without compromising its quality of life.

## REFERENCES

- Bland, E. (2007, April 12). Island of trash or the 'Garbage of Eden'?. *New Scientist*, 2599. Retrieved from <http://www.newscientist.com/article/mg19425991.600-island-of-trash-or-the-garbage-of-eden.html>
- Department of Statistics Singapore (2012, May 12). Key annual indicators: 2011. Retrieved from <http://www.singstat.gov.sg/stats/keyind.html>
- Inter-Ministerial Committee on Sustainable Development (2009, Aug 3). A lively and liveable Singapore: strategies for sustainable growth. Retrieved from [http://app.mewr.gov.sg/data/ImgCont/1292/sustainableblueprint\\_forweb.pdf](http://app.mewr.gov.sg/data/ImgCont/1292/sustainableblueprint_forweb.pdf)
- Leong, W.K. (2011, June 21). Monocle ranks Singapore as 15th most liveable city in the world. *Channel News Asia*. Retrieved from <http://www.channelnewsasia.com/stories/singaporelocalnews/view/1136260/1.html>
- Mercer (2012, July 11). Mercer's 2011 Quality of Living Ranking Highlights – Global. Retrieved from <http://www.mercer.com/articles/quality-of-living-survey-report-2011>
- National Climate Change Secretariat. (2012, Jun 14). Climate Change & Singapore: Challenges. Opportunities. Partnerships. Retrieved from <http://app.nccs.gov.sg/data/resources/docs/Documents/NCCS-2012.pdf>



# Camilo Santamaría- Gamboa, Colombia



45

## Sustainable Cities: Stockholm and the New Neighbourhood of Hammarby

Colombian Construction Council of Sustainability

E-mail: [csantamaria@santamariaurbanismo.com](mailto:csantamaria@santamariaurbanismo.com)

CAMILO SANTAMARÍA-GAMBOA

### ABSTRACT

Sustainable cities; Stockholm and the new neighborhood of Hammarby Sjöstad Stockholm, the capital of Sweden is among the 10 cities with the highest quality of life in the world.

In 2004, as part of the Olympic Games postulation, a former industrial area was proposed to become a sustainable district with the Olympic Village as its core, in order to recover the land and to avoid urban growth on rural land.

With the intention of finding synergies between urban technological systems, resources savings and lower costs, an area of 200 hectares was developed with a mixture of uses and high densities for almost 24 000 inhabitants. The recycling and reuse of waste to generate heat, biogas, the use of solar collectors, the reuse of water, amongst others, reducing the cost and consumption of natural resources by and almost 60% thus becoming a model of sustainable urbanism.



Overview of Hammarby, the New Neighborhood in Stockholm.

Photo: Lennart Johansson, "Hammarby Sjöstad a unique environmental project in Stockholm"

The conference is about the New Neighborhood of Hammarby in Stockholm which is an urban renovation of an old industrial area where the concept of Symbiocity was developed.

Stockholm, the capital of Sweden is among the 10 cities with the highest quality of life in the world.

Since January 2010, Stockholm is the "Green Capital of Europe", a title first awarded by the European Commission. This award recognizes the ability to solve environmental problems in order to improve both the quality of life of its citizens and that of the entire planet.

In 2004, as part of the proposal to hold the Olympic Games in Stockholm, a tract of former industrial land was proposed to be developed as a sustainable district with the Olympic Village as its core in order to recover the land and to avoid urban growth on rural land.

With the intention of finding synergies between urban technology systems, saving resources, and lowering costs, an area of 200 hectares was developed with different uses and high densities for almost 24000 inhabitants, promoting the recycling and reuse of waste to generate heat, biogas, the use of solar collectors, the reuse of water, amongst others, reducing the cost and consumption of natural resources in almost 60% and thus becoming a model of sustainable urbanism.



Emphasis in public transport.  
Photo: Camilo Santamaría-Gamboa



Intermodal transportation model.  
Photo: "Hammarby Sjöstad a unique environmental project in Stockholm"

### FACTS ON THE MASTER PLAN

- Hammarby has 200 hectares, of which 40 are water.
- The project has about 10.800 apartments with a density of 115 dwellings per useful hectare.
- Most of the buildings are up to 6 stories high.
- 30% of the developed area is for offices, industry and commerce. The number of jobs predicted is 10.000. In 2007 there were 5.193
- The new district is designed for 24.000 inhabitants. Today there are 17.000
- 55% of the dwellings have underground parking and 15% have public parking on the street.
- 50% are householders and the other 50% pay rent.
- There are dwelling units from 40 m<sup>2</sup> up to 120 m<sup>2</sup>. The number of rooms varies.
- 30 architectural firms participated, one for almost 3 blocks.
- 30 construction firms participated, one for almost 3 blocks
- 15% of the investment was made with public resources. The other 85% was made with private resources.
- The unemployment rate is 1.2% in Hammarby and 2.4% in the city.
- Transportation: 52% uses the public transport, 21% uses cars, and 27% use bicycles or walk.
- 50% of the electricity comes from the reuse of waste.
- Panels and solar cells are installed on the roofs and facades of some buildings.
- 50% of the energy that water heaters require comes from solar collectors.
- A waste disposal system drives and transmits by pneumatic the solid waste, pre-sorted and classified to be recycled or used to produce heat and electricity.



Model of the waste disposal system.  
Photo: [www.envac.es](http://www.envac.es)

## SYMBIOCITY

“Symbiosis means the integration of two or more organisms in a mutually beneficial union”.\*

Looking at the city as a whole we find benefits through synergies in urban functions, like turning waste into energy instead of landfills.

Users do a Waste Treatment Classification into three categories: Biological Waste, Paper, and the remaining waste.

The categorized waste is moved by a pneumatic system to the processing centers. Fertilizers are produced with the biological waste, the paper is shredded, and the rest is burned in a district cogeneration plant to produce electricity, hot water, and heating for homes.

Water Treatment: The rainwater is filtered and purified and then is diverted to green spaces or wetlands, or simply ends at the lake. The residuals go to a treatment plant where they are used to produce biogas, which also serves for kitchen use and fuel (with ethanol) for buses. It then goes to a place where waste heat is recovered that complements what is obtained in the cogeneration plants. What remains is used to obtain nutrient-rich soil.

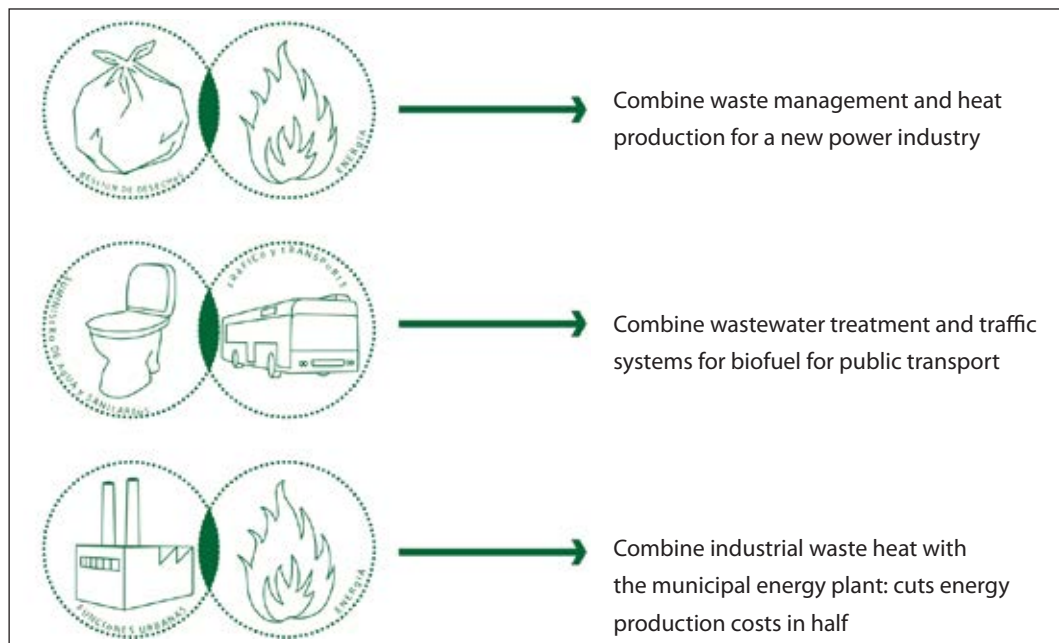

The symbiosis in simbiocity, [www.symbiocity.org](http://www.symbiocity.org)

The concept of Symbiocity, [www.symbiocity.org](http://www.symbiocity.org)



A view of the public space and the buildings in the project.

Photo: [www.symbiocity.org](http://www.symbiocity.org)





## **Prof. Dr. Adel S. El Menchawy, Egipt**

### **Ecoresorts – A Type of Sustainable Architecture**

AASTMT – Arab Academy for Science and Technology and  
Martín Transport

E-mail: [dradelsamy@yahoo.com](mailto:dradelsamy@yahoo.com)

#### **ABSTRACT**

Ecoresorts are environmentally sensitive and are managed in a manner that promotes the conservation and protection of natural and cultural resources. They are characterized by environmentally sustainable design, energy saving, waste management, and water conservation.

The design criteria for Ecoresorts achieve ecotourism goals, preserve the natural, socio-cultural and technical dimensions of sustainable development, using local building materials and preserving the local vernacular architecture and traditional construction techniques to reflect the identity, traditional, and local context.

Also, using renewable energies in resorts (i.e solar and wind power) can create environmentally eco-friendly resorts, conserve natural resources, and minimize the impact on the environment. Local Examples from the Middle East countries will clarify the previous points.

By the late twentieth century, ecotourism and nature-based tourism arose, which provided travelers with a sense of nature and culture. As a result of the integration between sustainable development and ecotourism, a new type of resorts emerged called 'ecoresorts'. They follow all ecological strategies, starting from the planning and design process, site selection, construction techniques, management and operation.

The term 'ecoresort' can be divided into two components, ECO and RESORT. The term 'eco' is derived from ecology that study the interactions of organisms (plants and animals) and their physical and biological environment, while the term 'resort' includes at least three features: Areas that offer touristic attraction, their population, ( visitors or transients), and their economy. An ecoresort project acts as a window to the natural world and as a vehicle for environmental learning and understanding. It requires the adoption of a different approach to architecture, commonly termed as eco-design.

An ecoresort is constructed using locally produced or recycled materials. It relies on solar or alternative energies, recycles the waste and waste water, it generates and serves locally grown and produced food. It minimizes the adverse effects of building techniques on the natural environment, and enhances the cultural integrity of local people. They promote natural building materials such as mud bricks, masonry, wood, thatch, ...etc., energy efficiency, water conservation and creation of economic opportunities for local communities.

The paper deals with the ecological design process of a resort project and the factors that affect the site selection and location of a resort. It also deals with the traditional techniques in construction to achieve Ecoresorts that can be adapted by appropriate sustainable design.

## OBJECTIVES

The main objectives of the presentation are as follows:

- Determining the design criteria for ecoresorts during the stages of design and construction.
- Minimizing pollution on the surrounding environment.
- Preserving the natural and cultural dimensions of sustainable development.
- Encouraging local vernacular architecture and traditional construction.

## STRUCTURE

It paper consists of five parts as follows:

1. Definitions.
2. Eco resort material.
3. Eco resort design.
4. International example
5. Conclusions.

## 1. DEFINITIONS

**Sustainable Development:** 'the development which meets the needs of the present without compromising the ability of future generations to meet their own needs' (1)

**Ecology:** Is the study of the relationship of plants and animals and their environment. The flow of material and energy between things within their environment, in their spatial context (2).

**Ecotourism:** Is a sustainable form of natural resource-based tourism that focuses primarily on experiencing and learning about nature, and which is ethically managed to be low-impact, non-consumptive and locally oriented (3)

1 [www.arch.hku.hk](http://www.arch.hku.hk)

2 Williams, 'Sustainable Design: Ecology, Architecture, and Planning', [2007],

3 Fennell, 'Ecotourism: An Introduction', [1999]

**Ecoresort:** Is a self-contained, nature-based accommodation facility, characterized by environmentally sustainable design, development and management, which minimizes its diverse impact on the environment particularly in the areas of energy, waste management and water conservation (4).

## 2. ECO RESORT MATERIALS

The choice of appropriate materials from the environment affects the resort structure, form, aesthetics, cost, method of construction and internal and external environments.

1. **Adobes** are sun-dried mud bricks stacked with a mud mortar to create thick-walled structures. Their use dates back centuries in traditional earth-building areas such as North Africa and the Middle East. Mud bricks proved its low cost and energy efficiency. Adobe bricks are made with mixture of clay and sand and sometimes straw (Fig. 1. 1,2,3).
2. **Rammed Earth** Rammed earth is an ancient earth-building technique can be used as earth is dug up on site. It is thus possible to create resorts composed of materials which are both natural in origin, locally sourced and resulting in nearly zero emissions. This technique last for hundreds of years, it is also used to set-up low cost building (Fig. 2.1).



Fig. (1.1): Mud clay and straw are mixed and pressed into moulds

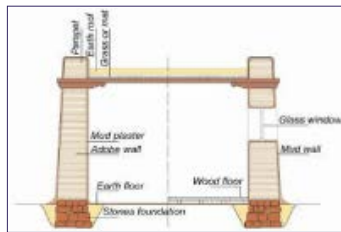

Fig. (1.2): Section shows the adobe building technique



Fig. (1.3): Adobe is used in New Gouna Village (Hassan Fathy)

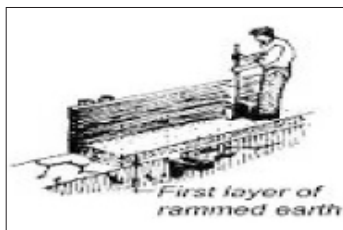

Fig (2.1): The rammed earth in layers using hand tampers



Fig (2.2): Exterior walls are built with straw bale



Fig (2.3): Building with straw bale



Fig (3.1): Masonry view, seating area (Quseir Movenpick), Egypt



Fig (3.2): A wall in El Gouna uses masonry – by Michael Graves



Fig (3.3): A view for a restaurant made from bamboo

3. **Straw Bale Construction** Is the best known example using a zero emission, fully renewable, virtually waste product and as a replacement of materials for resort construction such as concrete blocks, giving very high levels of insulation. With a natural plaster, straw bale walls 'breath' provides a quiet and healthy interior environment (Fig.2. 2,3).

4 Jafari, 'Encyclopedia of Tourism', [2000]

4. **Masonry Construction** Masonry walls are mainly used in low-rise buildings, and for internal separation of rooms, ducts and corridors (Fig 3.1,2).
5. **Wood** Wood is a natural material which is infinitely renewable and has no toxic or polluting effect on the environment. Wood is considered an ideal building material as it is strong, easily worked and beautiful (Fig 3.3).
6. **Thatch** The use of reeds, or palm fronds as a roofing material is common in many countries (Fig. 3.3).

### 3. ECORESORTS DESIGN

Ecoresorts considers the design process of a resort starting with site survey and selection, master plan, detailed design, construction and operation. Also, it considers the planning factors; i.e the location of the resort, the arrangement of its buildings, the separation of the vehicle and pedestrian movement, privacy, view and visual hierarchy, contact with nature, creating a resort image, and landscape.

An eco-resort extends beyond the use of materials, energy efficiency and low impact environment. Additional components such as, durability and adaptability over time, quality of indoor and outdoor areas, improve the usage of a resort. The sustainable design of resorts can lead to a variety of economic benefits. These include the economic benefits of energy, water and material savings, as well as reduced maintenance and other operational costs.

The local vernacular architecture reflects several aspects of sustainability through the design of some elements such as the courtyard, mashrabiya,..etc. which provides a socio-cultural image of sustainability, that is why in Arab countries, courtyard houses provide satisfactory cultural advantages along with climatic benefits, while the atrium provides the necessary daylight and air change (Fig 4.1,2,3).



Fig. (4.1) Courtyards in Sidi Driss Tunisia, for climatic and defense



Fig. (4.2): Sheraton Miramar Main hotel by Michael Graves



Fig. (4.3): Sheraton Miramar guestroom brick domes

An ecoresort design consideration starts by site surveys and selection. Then the architect begins to settle his idea based on natural, cultural, climatic and marketing attractions. Detailed design take into consideration the need for future extensions, then comes the governmental regulations and approvals. Panoramic view, vehicular and pedestrian circulation, man-made landscape, privacy, visual hierarchy, contact with nature, distribution of buildings, ..etc. are important factors that are taken into account. To conclude, an ecoresort acts as a window to the natural environment and as a vehicle for environmental learning and understanding.

Criteria	Strategy
Site Survey & Selection	Includes Natural attractions, cultural / Heritage, micro-climatic considerations, labor, services & facilities, and marketing
Master Plan	Create an attractive ecoresort, which will satisfy the marketing, functional and financial criteria (Fig.6.4)
Circulation	Separation of vehicles and pedestrians (Fig 6.1)
View	Water front and surroundings are key factors (Fig 5, Fig 6.3 )
Landscape	Form a natural screening, setting for pools and terraces, unit buildings, provide shelter for car parking and pedestrian walkways, moderate the microclimate, enhance habitats for flora and fauna, prevent soil erosion, purifying the air, providing noise protection and privacy, defining space, protection from glare and wind, and usually prefer tropical local plants (Fig 6.6)
Privacy	Separation between service, management, accommodations zones, and swimming pool (Fig 6.5)
Visual Hierarchy of Spaces	Begins from the resort entrance, then spaces leading to management and service zones, accommodation units, beach, recreational activities and swimming pool.
Nature Contact	Establish a good relationship between a resort and its natural environment
Distribution of Buildings	Plan should provide attractive relationships between buildings, and extension facilities (Fig 6.4).

Table (1): Criteria for Designing an Ecoresort



Fig (5): Intercontinental Taba Heights, Egypt. The beach and slope are the main factors of the natural constraints

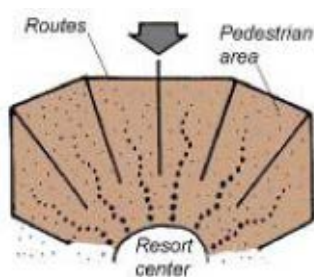

Fig ( 6.1 ) : separation of vehicles and pedestrians



Fig (6.2): Visual hierarchy-the main entrance of Royal mirage, Resort, Dubai,

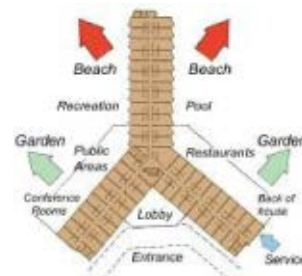

Fig (6.3) The view influence the plan form 90 degree - view of both land and water



Fig (6.4): layout of Grand Hyatt, Bali, is planned from four clusters



Fig (6.5): Water integration with landscape (Hayatt Regency Bali)



Fig (6.6): Plants surrounds the swimming pool (Bali, Indonesia)

#### 4. INTERNATIONAL EXAMPLE: ADREE AMELLAL ECORESORT (SIWA, EGYPT)

The oasis of Siwa is a fertile depression nestled deep in the western desert of Egypt. The resort overlooks olive and palm grooves, Siwa's largest lake, and the sand dunes of the Western desert of Egypt (5) (Fig. 7.1,2).

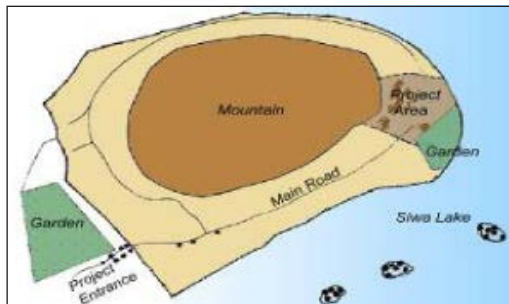

Fig (7.1): The location of Adree Amellal Ecoresort is located in the middle of the oasis and surrounded by Siwa's lake

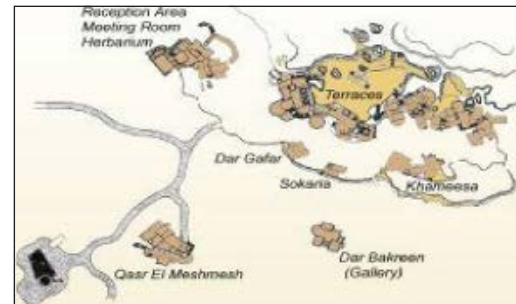

Fig (7.2): The layout of Adree Amellal Ecoresort

#### PROJECT OBJECTIVES

- Preservation natural and cultural assets of the region.
- Learn about its unique ecological and geological features.
- Focus on history, culture and traditions of its people.
- Benefiting the local community, and strengthen the local economy by employing local workers, using local materials and products.
- Applying traditional skills and systems of building and environmental management.
- Marketing the region as a special travel destination.

#### DESIGN OVERVIEW

The ecoresort and the desert park grounds occupy an area of 60 hectare. The resort consists of 27 units, including suites and rooms in addition to a reception area, a kitchen and dining areas, a large outdoor stone pool fed by spring water from a restored ancient Roman well, and a library (Fig 8).

Waste and wastewater produced at the resort are recycled, solid waste is separated at source. Organic wastes is composted in a compost pit and used as a fertilizer in agriculture, where fruits and vegetables are organically grown (6).

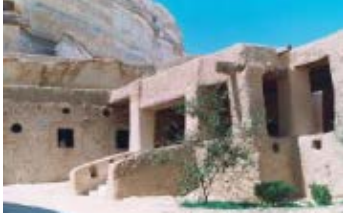

Fig (8.1): The entrance with small windows to capture the prevailing wind



Fig (8.2): The walls are built using kershef natural material to keep the rooms cool



Fig (8.3): The roofs of the buildings are built from palm trunks which reduces heat gain inside the building



Fig (8.4): The buildings carved into stones with thick walls creates cool areas



Fig (8.5): The accommodation units follow the traditional design and is made by local skills

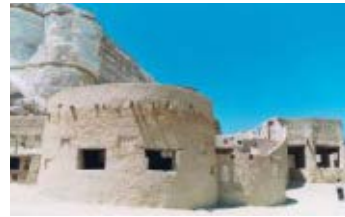

Fig (8.6): The rough texture of the building plaster creates shaded areas on the facades

## 5. CONCLUSIONS

An ecoresort is constructed using locally produced or recycled materials. It relies on solar or alternative energies, recycles the waste and waste water, it generates and serves locally grown and produced food. It minimizes the adverse effects of building techniques on the natural environment, and enhances the cultural integrity of local people. They promote natural building materials. They have the following characteristics:

1. Provides internal human comfort.
2. Are adapted to fit the surrounding site context and landscape.
3. Local community benefits from ecoresorts, by improving the local economy, employing local workers, and attracts tourists.
4. Transfer the know-how and use traditional building techniques.
5. Conserve the cultural heritage and natural history of the local region, and adopts it through the vernacular practices.
6. Use local materials with low negative impact on the environment
7. The main architectural design criteria for an ecoresort are: Site survey & selection, master plan, circulation, view, landscape, privacy, visual hierarchy of spaces, nature contact, and buildings distribution. When the previous criteria are considered early in the design process, they reduce life-cycle costs.





# Prof. Dr. Daniel Favrat, Switzerland



## Efficient Energy Systems for Buildings and Cities

Vice-chair WFEO energy committee and Prof at Swiss  
Federal Institute of Technology of Lausanne

E-mail: [daniel.favrat@epfl.ch](mailto:daniel.favrat@epfl.ch)

### ABSTRACT

The satisfaction of human comfort needs in buildings and cities is, so far, one of the most energy-consuming and pollutant-emitting task. It is characterized by long term investments, both in passive and active measures. Advanced active technologies for heating, cooling and/or decentralized electricity production, including more and more sophisticated urban energy networks, are introduced. The importance and difficulties of information structuring in urban areas via geographic information systems combined with energy system optimization is highlighted through examples in Tokyo and Geneva. An original network concept towards cities without chimneys or cooling towers is being briefly discussed.

## INTRODUCTION

Urbanization grows at a high rate in most parts of the World. The energy part dedicated to comfort and domestic hot water often exceeds 40 % in many industrialized countries like Switzerland (fig 1) and the life of buildings can extend from half to several centuries like in many European cities for example. Therefore any investment in building envelopes and technologies implies a long duration and decisions of today have a long lasting impact. The rate of introduction of new building varies from one to two percent in many areas and retrofit of older buildings is therefore crucial if serious action towards sustainability is intended. Due to the different building ownership resulting in different rehabilitation strategies cities tend to be heterogeneous in energy and temperature level needs when it comes to comfort satisfaction, be it for heating or for cooling. This paper will concentrate on the need of cities in countries where both heating and cooling are required.

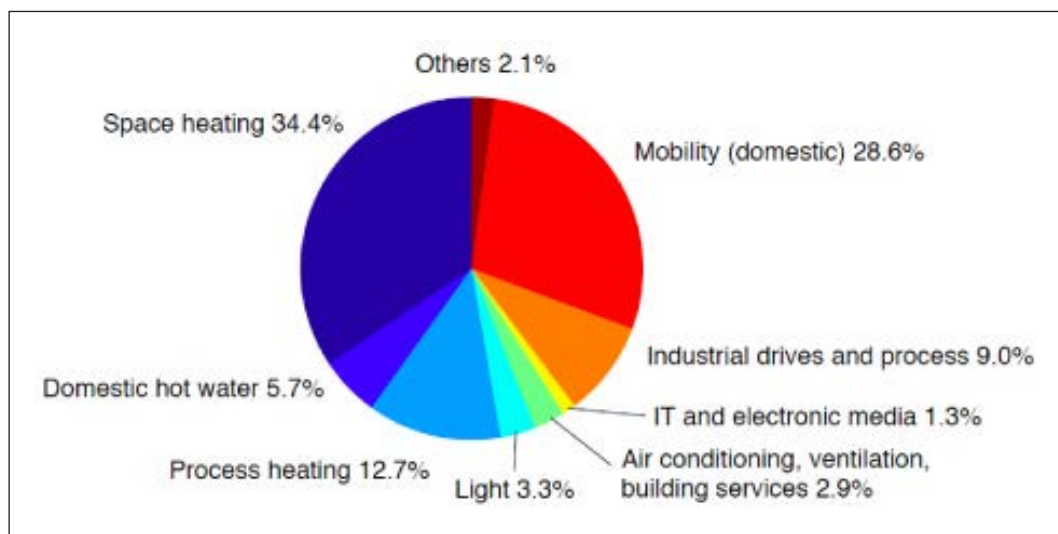

Figure 1: Example of national end-use of energy (Switzerland, 2010 [1])

## HEATING AND HOT WATER SERVICES

The main ways to reduce energy use for heating are the passive measures with the improvements of the building envelope (windows, wall and roof insulation, ...) and the active measures (electrical or thermal heat pumps, thermal solar panels, wood or biogas units and/or co- or tri-generation units)

Historically men discovered fire to heat and cook some 400'000 years ago. Today we just put an insulated box around the fire and call it a boiler. Worse, we primarily burn into it hydrocarbons that are very valuable resources that have been transformed throughout millions of years. Can we really define boilers as 21<sup>st</sup> century technology? The answer is of course not and figure 2 illustrates some of the more intelligent paths to supply heating services. With the same unit of energy from either fossil or renewable fuels we can generate twice as much heat compared to a modern boiler by either:

1. Burning the fuel in a combined cycle power plant with electrical efficiencies (including transport losses) of the order of 57% and use the electricity to drive an brine –water electrically driven heat pump with a COP of 3.5. The net result is twice as much heat than an ideal boiler
2. Converting the fuel in a cogeneration fuel cell unit and also use the electricity to drive a similar type of heat pump. This also results in twice as much heat if one adds the heat from the fuel cell and the heat supplied by the heat pump (both equipments not necessarily needing to be at the same location)
3. Burning the fuel in a trithermal heat pump (absorption or ORC-ORC thermally driven heat pump unit [2]) with expected heat supply close to 200% as well.

These examples illustrate the substantial potential of energy and CO<sub>2</sub> emission savings that can be expected in the future.

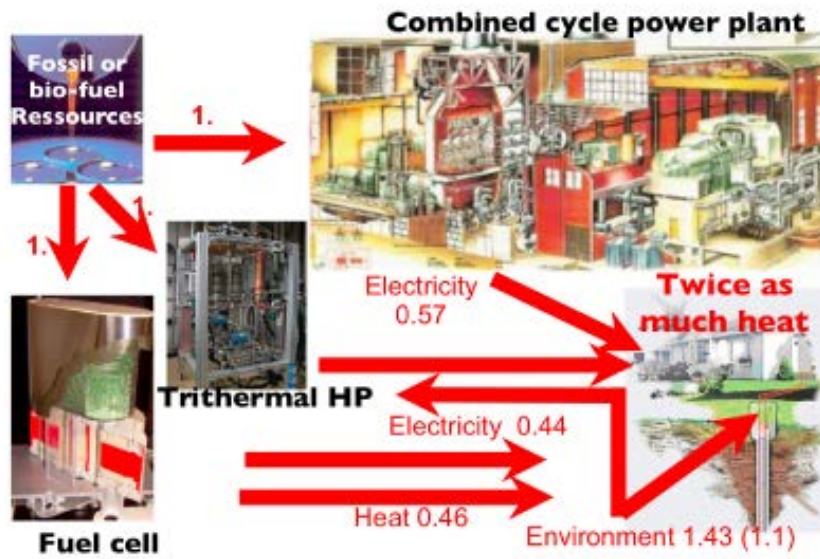

Figure 2: Examples of technological combinations to supply heat more ecoefficiently than with boilers

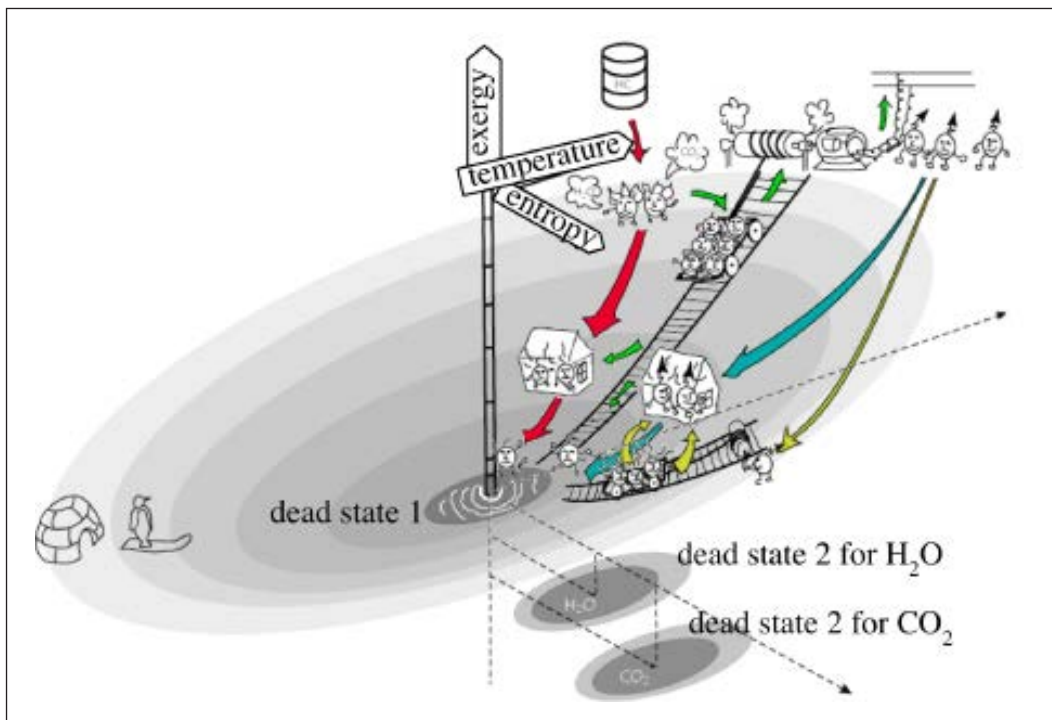

Figure 3: Representation in the exergy bowl of different heating modes [3]

The same point can be quantified using the concept of exergy, combining the First and Second Law of thermodynamics. As a reminder, the exergy of a flow or a stock expresses the equivalent maximum work that could be recovered by converting the considered energy using reversible thermodynamic processes and exchanging energy only with the local environment. Figure 3 shows the exergy bowl, sometimes called coenergy bowl [3], with fuels (HC) or electricity at the highest exergy level and at the lowest exergy level the

various dead states (thermo-mechanical (1) or physico-chemical equilibria (2)) with regards to the atmosphere. In this representation the exergy of hydrocarbon decreases into the exergy of the stable products of combustion  $\text{CO}_2$  and  $\text{H}_2\text{O}$ . In a boiler those products then provide heat at the low exergy level of the house and finally end up in the dead state 1 of thermo-mechanical equilibrium with the atmosphere. The rails immediately to the right illustrate a power plant with some of the energy units going down to the dead state while other energy units are pulled up at the high exergy level in the form of electricity. In case of cogeneration the energy units going down supply heating services to buildings on their way down. Electricity could then be used to either heat the buildings directly, which is process having the worst heating efficiency, or to drive a heat pump that allows the upgrade of heat from the atmosphere (environment).

Even though the concept of exergy efficiency is not new, it has a rejuvenated role to play in a time regained interest for energy since it gives a new insight to guide the design and planning of ecoefficient heating systems. For example it is one of the sustainability indicators recently introduced in a law on energy in one canton in Switzerland [4]. Table 1 shows the exergy efficiency of various combinations of technologies for heating and similar values for cooling can also be found in [4]. The main recommendations that can be derived from the concept of exergy efficiency are:

- Heat at the lowest temperature as possible
- Cool at the highest temperature as possible

Heat pumps with or without electricity from cogeneration are essential technologies to improve the efficiencies of heating and reduce greenhouse gas emissions.

The overall exergy efficiencies in [4] are defined using the heat supplied multiplied by the Carnot factor at the numerator, divided by the exergy value of the fuel, the only exception being nuclear electricity (see [5] for more on the subject). The Carnot factor is calculated with 273K for the environment and 293K for the required room temperature. The low level of overall exergy efficiencies indicates that there is a good margin for progress in implementing heating technologies.

Table 1: Exergy efficiencies of different technologies for heating [4]

Technologies	Power plant	Dist. plant	Building plant			Room convector			Overall exergy efficiency (%)		
			45°/35°	65°/55°	75°/65°	45°/35°	65°/55°	75°/65°	45°/35°	65°/55°	75°/65°
Supply/return temperatures			45°/35°	65°/55°	75°/65°	45°/35°	65°/55°	75°/65°	45°/35°	65°/55°	75°/65°
Direct electric heating (nuclear power)	0.32					0.07	0.07	0.07	2.2	2.2	2.2
Direct electric heating (combined cycle cogeneration)		0.55				0.07	0.07	0.07	3.7	3.7	3.7
Direct electric heating (hydro power)	0.88					0.07	0.07	0.07	6.0	6.0	6.0
District boiler		0.2	0.54	0.76	0.86	0.53	0.38	0.33	5.8	5.8	5.8
Building non-condensing boiler			0.11	0.16	0.18	0.53	0.38	0.33	6.1	6.1	6.1
Building condensing boiler			0.12			0.53			6.6		
District heat pump (nuclear power)	0.32	0.61	0.54	0.76	0.86	0.53	0.38	0.33	5.6	5.6	5.6
Domestic heat pump (nuclear power)	0.32		0.45	0.45	0.45	0.53	0.38	0.33	7.6	5.4	4.8
Domestic cogeneration engine and heat pump			0.22	0.25	0.26	0.53	0.38	0.33	11.8	9.4	8.7
District heat pump (combined cycle power)	0.54	0.61	0.54	0.76	0.86	0.53	0.38	0.33	9.4	9.4	9.4
Domestic heat pump (combined cycle power)	0.54		0.45	0.45	0.45	0.53	0.38	0.33	12.9	9.2	8.1
Domestic heat pump (cogeneration combined cycle power)		0.55	0.45	0.45	0.45	0.53	0.38	0.33	13.2	9.4	8.3
Cogeneration fuel cell and domestic heat pump			0.25	0.27	0.28	0.53	0.38	0.33	13.4	10.4	9.5
District heat pump (hydropower)	0.88	0.61	0.54	0.76	0.86	0.53	0.38	0.33	15.4	15.4	15.4
Domestic heat pump (hydropower)	0.88		0.45	0.45	0.45	0.53	0.38	0.33	21.2	15.1	13.3

## A CRUCIAL PART: KNOWING THE DEMAND BOTH IN ENERGY AND TEMPERATURE

As shown above heat pumps will have to play a bigger role in the future. They imply however a change of paradigm since their heating effectiveness ( $COP_h$ ) is improving with lower temperatures of the heating distribution circuit or their cooling effectiveness ( $COP_c$ ) is improving with higher temperatures of the cooling distribution circuits. When planning new urban heating and cooling systems for cities or parts of cities it is therefore important to know not only the heating or cooling loads of the buildings but also the temperature required by the distribution networks inside the buildings that is a function of the room convectors installed. The famous maxim of the Greek philosopher "Know thyself" is unfortunately far from being respected in cities. Geographic Information Systems (GIS) partially exist in various forms but are generally not integrated enough and often lack crucial informations.

An interesting methodological path was developed within the framework of the Alliance for Global Sustainability (AGS) between the University of Tokyo, MIT and the Swiss Federal Institutes of Technology within a project called "Tokyo half" that is to say how to imagine a city like Tokyo emitting only half of the greenhouse gas emissions (<http://www.globalsustainability.org/tokyo-half-project.htm>). From an extensive GIS database of the city of Tokyo, sets of technologies were modelled and optimized to meet the various energy demands. One example of this approach is shown in [6] when applied to the trigeneration of heat, cold and electricity in a part of Tokyo. This thermoeconomic study highlights the alternatives to achieve such a target based on a superstructure including hybrid fuel cell-gas turbines with either absorption or mechanical heat pumps and chillers. A similar approach has been applied to the city of Geneva, extending it to the heating and cooling temperatures needed in the building based on general assumptions on age of the building when the temperature requirements were not available in the database( Fig 4 [7]).

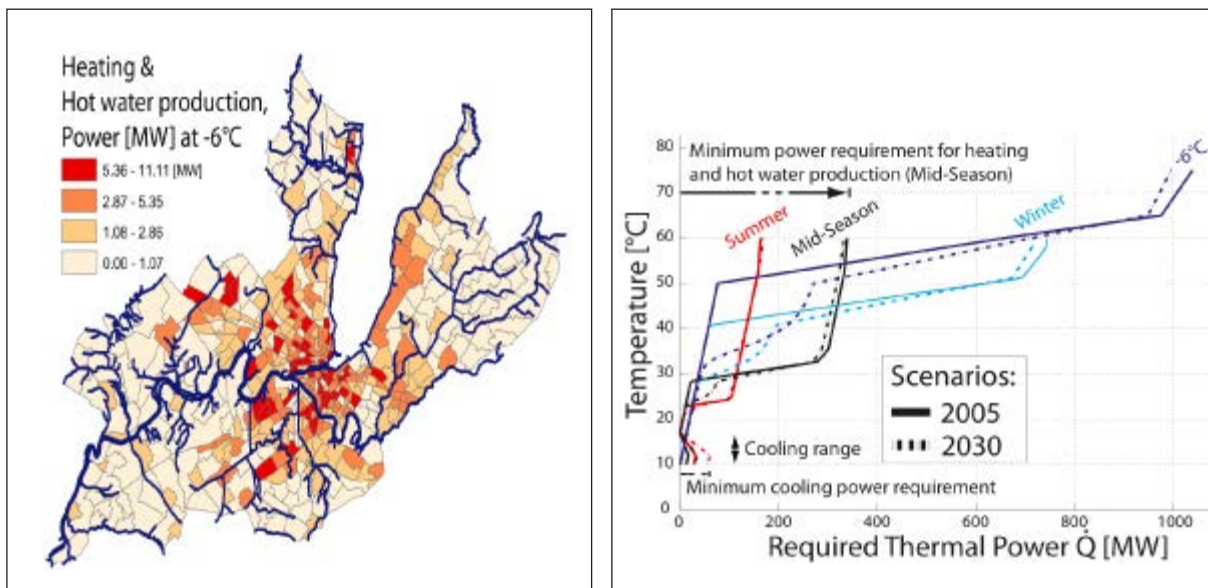

Figure 4: Heating needs of the canton of Geneva and composites of the demand [9]

From the adequate GIS data single or bi-objective optimisations including costs and the internalisation of some of the environmental costs can be achieved. One example of results for a district heating network including cogeneration, centralized and decentralized heat pumps is shown in [8].

Those references illustrate the importance of energy networks in cities since the cold source for heat pumps is not as straight forward as in the individual houses in the suburbs.

For cities located close to large bodies of water (sea, lakes) the application of district heat pumps is rather simple as shown for example in [9]. One possibility of cold source that is exploited in a number of cities is the energy in the water from sewage upstream or downstream of the waste water treatment plant. Let us cite the two largest heat pumps of the world that are installed in Goteborg (Ria 3 and 4) each supplying 45 MWth.

More recently, as cooling needs are growing, cold networks have developed distributing the lake water directly through a part of city to satisfy primarily cooling needs, but with an extension to also satisfy the heat needs via decentralized heat pumps.

Most district heating and cooling networks so far are based on water using the sensible heat to supply the required energy. The major drawback of these approaches are a loss of exergy potential due to the large temperature gradient required to have a network viable economically. Furthermore this usually requires large pipes (two for heating and two for cooling in the underground of city streets that is already well occupied but in an often badly documented way.

A novel concept of district heating and cooling network [10] has been recently proposed based on the circulation of a natural refrigerant ( $\text{CO}_2$ ), using the latent heat of the transfer fluid for heat and cold supply to decentralized heat pumps or refrigeration units. The advantage of this two pipes concept (one saturated vapor and one saturated liquid pipe with dual flow direction capability), represented in figure 5, is to require smaller diameters and therefore lower trench requirements too and allow an increased synergy between waste heat producers and waste heat users within the city. The network acts then as an energy umbilical cord within the city in which decentralized cooling towers and chimneys can be eliminated except at the location of the central plant. Expected performance and profitability of such a system, applied to an existing city part, are given in [11]. Dynamic modelling towards the implementation of a demonstration network is under way. Moreover this type of network could act as a collecting pipe for the  $\text{CO}_2$  separated from advanced fuel cell-gas turbine cogeneration systems such as proposed in [12].

Electricity storage is also becoming of increasing importance when considering the energy needs of a city. Apart from batteries, flywheels and compressed air units, a new concept of electricity storage based on alternative heat pump and power cycles successively heating and cooling water reservoirs has recently been proposed [13]. It operates based on the supercritical cycles shown in figure 6. Since one option is to operate with  $\text{CO}_2$  there is an obvious potential link with the  $\text{CO}_2$  district energy network proposed above. In addition complementary heat inputs from thermal solar panels could also be considered as proposed in [14].

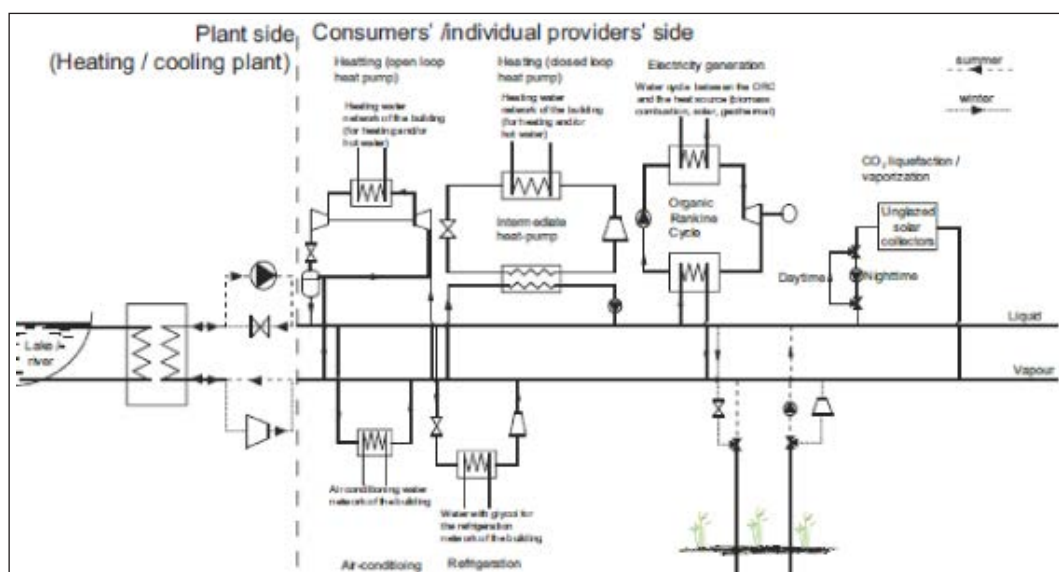

Figure 5: District heating and cooling network based on the distribution of  $\text{CO}_2$  [10]

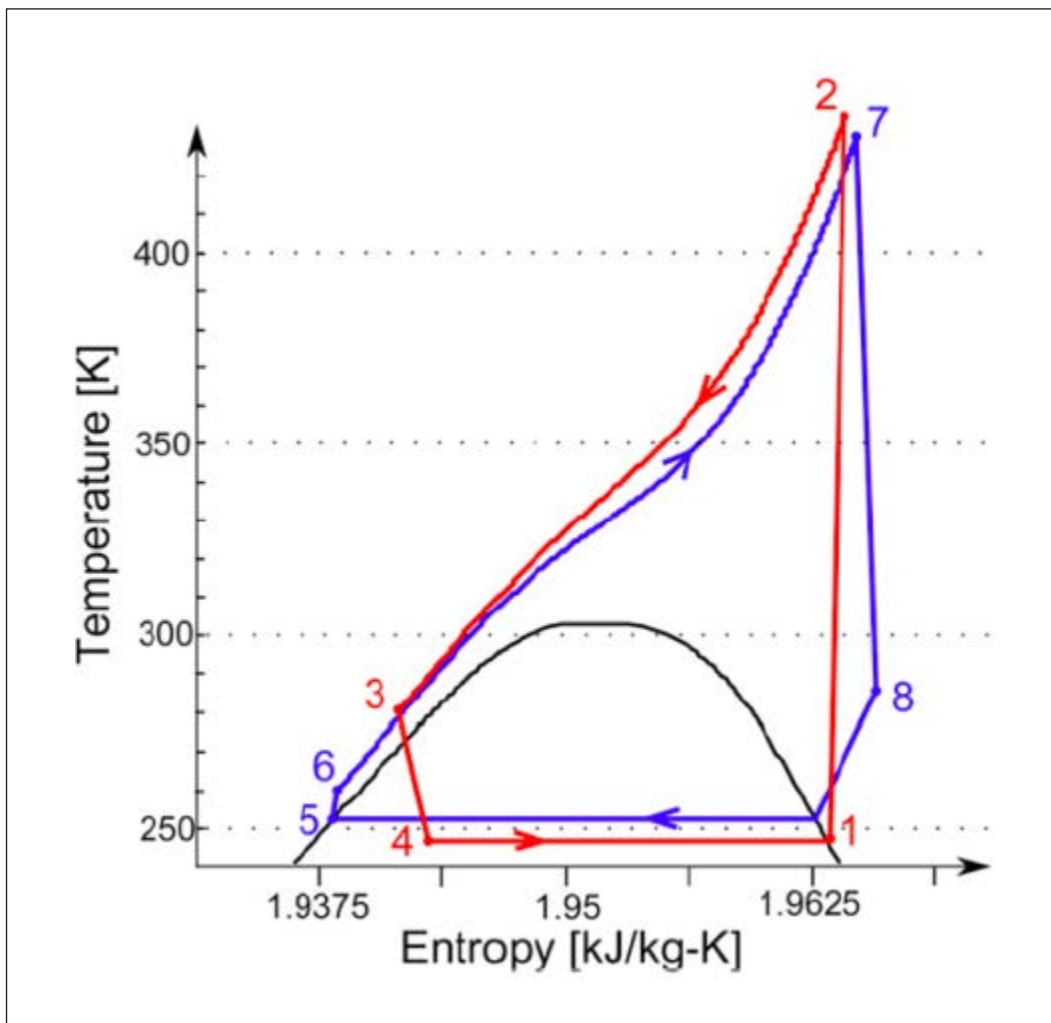

Figure 6: Alternate heat pump and power CO<sub>2</sub> cycles for electricity storage via a hot water storage tank [13]

## CONCLUSIONS

Cities offer a significant potential for energy improvements through modern approaches including heating and cooling networks as well as centralized and decentralized heat pumps and cogeneration units. These improvements concern both the heat and cold supplies as well electricity storage schemes. Further technologies based on fuel cells and CO<sub>2</sub> separation as well as novel CO<sub>2</sub> networks could also further improve the efficiency by reducing the exergy losses and increasing the synergy opportunities.

## REFERENCES

- [1] Authors, "Overall Energy Statistics". Swiss Federal Office of Energy, 2009
- [2] J. Demierre, S. Henchoz, D. Favrat, "Prototype of thermally driven heat pump based on integrated Organic Rankine Cycles (ORC)". *Energy*, 41(1), pp 10-17, 2012
- [3] L. Borel, D. Favrat, "Thermodynamics and energy systems analysis" vol 1 and 2, EPFL Press, 2010 and 2012.
- [4] D. Favrat, F. Marechal, O. Epelly, "The challenge of introducing an exergy indicator in a local law on energy". *Energy* 33 (2), pp130-136, 2008
- [5] F. Tani, PA Haldi, D. Favrat. "Exergy-based comparison of the nuclear fuel cycles of light water and generation IV reactors". *ECOS2010*, 2010

- [6] M. Burer, D. Favrat et al. "Multicriteria optimisation of a district heating cogeneration plant integrating a Solid Oxide Fuel Cell-Gas Turbine combined cycle, heat pumps and chillers", *Energy* 28 (6) pp 497 – 518, 2003.
- [7] L. Girardin, F. Marechal, D., "Energis: a geographical information based system for the evaluation of integrated energy conversion systems in urban areas". *Energy*, 35(2), pp 830-840, 2010
- [8] A. Molyneaux, G. B. Leyland, D. Favrat, "Environomic multi-objective optimisation of a district heating network considering centralized and decentralized heat pumps". *Energy* 35(2) pp751-758, 2010.
- [9] L. Girardin, M. Kallhovd, and F. Maréchal. "Application of the district cooling/heating network design models in the GLN area". Technical report, 2010a. URL <http://www.tetraener.com/>.  
TetraEner: Optimal balancing of demand and supply through RES in urban areas
- [10] C. Weber, D. Favrat, "Conventional and advanced CO<sub>2</sub> based district energy systems". *Energy* 35(12), pp 5070-5081, 2010.
- [11] S. Henchoz, D. Favrat, C. Weber, "Performances and profitability perspectives of a CO<sub>2</sub> based district energy network in Geneva's city center". *District Heating Symposium*, Copenhagen, September 2012
- [12] E. Facchinetti, D. Favrat, F. Marechal, "Innovative hybrid cycle solid oxide fuel cell-inverted gas turbine with CO<sub>2</sub> separation". *Fuel Cells*, vol 11, issue 4, pp 565-572, 2011
- [13] M. Morandin, F. Marechal, et al. "Conceptual design of a thermo-electrical energy storage system based on heat integration of thermodynamic cycles". *Energy*, in print, 2012.
- [14] S. Henchoz, F. Buchter, D. Favrat et al. "Thermoeconomic analysis of a solar enhanced energy storage concept based thermodynamic cycles". *Energy*, 41(1), pp 113-120, 2012.





## **Prof. Dr. Lars Bylund, Sweden**

### **Energy Autonomous Urbanisations for Emerging Economies and Developing Countries**

Bergen School of Architecture, Norway, DigiEcoCity, Finland

E-mail: [lars.bylund@yahoo.se](mailto:lars.bylund@yahoo.se)

#### **ABSTRACT**

The presentation will explain the idea and meaning of "Sustainable and energyautonomous" in urbanisation and buildings and describe some referens examples. Discussion about the problems and advantages in implementation of those technologies in various types of political, economical and climatical environments.

Arguments why this concept would be the preferable solution for new built environments and urbanisations, especially for emerging and developing societies.

## INTRODUCTION

An efficient energy management is the cornerstone for every society. The use of energy is present in every daily activity of our lives; transportation and preparation of water, food and disposal of waste.

Production and distribution of all kinds of commodities. Transportation not only using vehicles but also as simple as walking. Even undertaking the metabolic process to sustain living is primarily based on an intake of energy. This is regarded as trivial and so basic in the modern life that most people have stopped to think or even care about the use of energy. Except when thinking of the gasoline prices or the cost of the electrical bill.

How much energy do we really need to use to survive? The basal metabolism – the energy you need to sustain life – is about 2000 kCal/person which is 8.2 MJ/person. The people who survived on that amount of energy did not have the fire nor other devices that could make their lives more varied. When humans had learned to use fire the use of energy doubled many times not only because of use of the combustion energy but also because of their intake of energy for sustaining the metabolic process. For those people the use of energy is believed to have been doubled to 4000 kCal/person or 16.4 MJ/person.

About 6000 years ago, when people started to live in communities and used agricultural practices the use of energy increased significantly and is estimated to be about 50 MJ/person. This increase depended not only on a richer or larger intake of but also on use of other natural resources like material for building houses and in the agriculture the use of fertilizers.

In Europe about 500 years ago the use of energy was again nearly doubled to 90 MJ/person. The reason was that now people had increased the use of energy to produce materials not only for buildings but also a number of new tools, glass, and other goods for increasing the comfortable life.

During the industrialisation period until 1850 the energy usage increased to about 380 MJ/person. It must then be noted that the total global population was probably not larger than 1.5 billion people compared to today's 6 billion and tomorrow's 9 billion. For some societies of today the use of energy can be as high as 1 GJ/person. And globally this is the setpoint for the emerging economies and developing countries as well.

Today we are facing a serious increase in energy and resource demand because of steadily increasing population in the world. Even if the use per capita will not increase this will still be creating a number of problems.

It is an accepted fact that we already, with the present population, are using too much of available energy resources based on carbon such as oil, gas and coal. Except for coal with present use of energy and technology those fossil fuels will be finished within this century. Coal will last maybe another century.

Connected to this use of fossil fuels is the environmental problems they cause. Even if the use of energy is restricted and in the most possible efficient way with today's technology. A basic problem is the environmental problems caused by the methods used for energy conversion, i.e. production of electricity, mechanical work, heating and cooling buildings.

Those methods used for the conversion of mostly unsustainable primary energy, such as coal, oil, gas and nuclear for distribution to the users is the basic obstacle since in the energy chain the losses are about two thirds of the primary energy.

Here we face problems like global warming effects, ozone depletion, acid rains, destruction of rivers, deforestation of not only rain forests but in many countries forests at all, and finally the risky handling of nuclear waste.

As a consequence again it is important to take into account not only the energy output and the efficiency, but also environmental and social aspects. Added to this there are some hidden or not easily recognised costs related to the fossil fuel or unrenovable fuels dependence like above production costs since producers have market power, economic losses depending on price shocks, military or security expenditures and finally health and environmental impacts. As today it seems as coal impacts on environmental and health may exceed the market value of the coal produced.

Today still it is estimated that 1.4 billion people which is about 20 % of the global population do not have access to electricity and that another 1 billion do not have reliable access to electricity. That means that about 40 % of the global population rely mainly on biomass for cooking and lighting. Quoting IEA saying that, Although these statistics are well known to, many already engaged in the energy aspect of the development agenda, they serve as a relevant reminder of the scale of the challenge.

It is also worth reiterating that lack of access to modern energy services is most prominent in emerging economies and developing countries, although issues of energy access and energy poverty are evident throughout the world.

For those economies and countries there must be significant investments in traditional conversion energy technology. May be investments which will be regarded from economical point of view, unsustainable, meaning not profitable. Enormous investments have to be done in new energy grids as well as in production facilities and distribution of fuel of different unsustainable kinds.

In April 2011, the UN General Assembly declared this year, 2012, as the "International Year of Sustainable Energy for All."

As understood there are two aspects of this declaration that needs special attention. The first is that access to energy is vital for enabling economic growth, increasing productivity and improving overall health and welfare. Secondly, the word sustainable highlights the need to produce and use energy in such ways that support the global efforts to reduce the speed of climate change and improve efficient resource management.

Implemented in those settings there is also a kind of advice to those countries and regions which at the moment lack reliable energy sources to recognise that a high level of energy security is required to ensure that the energy services can support development and social goals.

Or in other words; secure energy autonomy without dependence of global energy oligopolis, organisations or nations. The most simple and economic way to ensure those things is the development and utilisation of renewable energy sources.

Why is this statement valid and realistic? Because as mentioned above, that the investments in a traditional conversion energy technology will be tremendously expensive, not only because of the establishment of new powerplants, which are based on nonefficient transformation technology, but also investments in power grids for secure electricity supply.

This is why in most emerging economies and developing countries renewable energy is competitive already today. Contrary to the unrenovable fuels, renewable energy sources does not need long distance and expensive distribution networks. Which also means decreased losses in the energy distribution network or infrastructure from primary energy to usable energy. This is regardless if the energy is in the form of electricity or heat.

Yet another reason is that the regulation of the energy market is still flexible and do not have to secure the profit of previous investments from private or public utilities. This makes it easier to create competition with other technologies than the traditional based on unrenovables.

## ENERGY AUTONOMY – A REALISTIC APPROACH?

“Unless there is an obvious reason to do otherwise, most of us passively accept decision problems as they are framed and therefore rarely have an opportunity to discover the extent to which our preferences are framebound rather than reality-bound.” Quote Daniel Kahneman, Nobel Prize in Economics 2002.

Before answering this above question, it is important to recognise the barriers to the realisation of energy autonomous entities. Who are the losers and who are the winners?

First of all and quite obviously, to be energy autonomous means that the energy sources are available without intermediaries. It could be temporarily or eternally. For some nations or groups this is in effect already today but the energy sources are finite like fossil fuels. Most countries or groups do not have access to those energy sources without intermediate actors, because those nuclear and fossil fuel reserves are found in relatively few places on the globe.

In a longer perspective and with the use of today's conventional energy production there will be no energy autonomous societies when the finite resources are ended. This means that every nation or group will benefit from the so called “energy change” sooner or later. At the moment, with the present situation in mind, the losers are those who are the dependent and the winners are those controlling the conventional energy sources, fossil fuels and nuclear. Those later have all reasons to argue for conventional energy production.

The arguments are mainly that renewable energy is unsecure because of not continuous production, the technologies are not matured or needs a lot of development and first of all – expensive and not cost effective.

It must be realised that all those arguments are without validity and used for postponing the energy change which will make the today independent to temporarily losers. In the longer run all parties should be the winners the sooner this energy change will appear. This should also release from investments in expensive infrastructure distribution systems that might in the future become obsolete.

Fossil and nuclear fuels are becoming more and more expensive if both direct and indirect costs are counted. This is due to higher production and distribution costs. But also because of a higher cost burden related to environmental and safety precautions. Just to mention the Mexican Gulf and Fukushima. On the other hand the renewable energies are becoming cheaper and cheaper due to continuous technological developments and increasing industrial production and the main reason – there are no fuel costs involved.

The main problem with this argumentation is the lack of holistic view. That is obvious that solar energy can not be provided locally on a 24-hours basis, it is also true that wind or wave energy is discontinues, that geothermal energy is not the cheapest investment and even hydropower could be unreliable under dry periods. Instead of looking at each source of renewable energy independently there must be again a holistic view.

The answer to the above question has to be that it is possible today to have energy autonomous entities, either as singular buildings like so called plus houses which is proven or whole urbanisations.

## HAMMARBY SJÖSTAD AS A REFERENCE.

As a guiding example of sustainable urbanisations the Hammarby Sjöstad, if not completely energy autonomous, is still useful. How the City of Stockholm was able to implement unconventional technologies into the urban planning in order to obtain a more sustainable environment.

Hammarby Sjöstad is a newly completed area located right on the border of Stockholm inner city. Development commenced in the 1990s. The background for making this area to a state of the art ecological and sustainable urbanisation had a number of reasons. In Sweden at the time since the 80s, there was a growing argumentation for "green" sustainable and energy efficient, not polluting environments.

Those discussion had a severe political impact at all levels. Especially since the Swedish asociation to the European Union and based on the 5th European Action Programme for the period 1993-2000, where the environmental policy became more central to each individual EU member state. Ther also states that there should be a re-orientation of economic and fiscal instruments towards technologies for resource efficiency and the internalization of environmental costs and strategies towards minmizing wastes as well as longer product life cycles. Ecological modernisation was the theory on how to govern this interaction.

1997 the Swedish governement decided about a programme for ecological modernisation and to encourage the local governements to increase the protection of the environment and reduce the use of energy, they allocated a subsidy of 5.4 billion SEK. This programme was called the "Local Investment Programme", LIP for short. Another sought effect of the subsidy was that it should create knowledge and advanced technologies and systems that could be exported to other countries. At that time this programme was regarded as an unique construction of making subsidies and it was necessary to have the green light from the EU commision. This was promptly given the same year.

Parallelly the Stockholm city had an area around what was called the Hammarby Sjö (Hammarby Lake) which had been assigned to host the Olympic games the year 2004. Stockholm did not get the games which were given to Athéns, and now the fate of the area was in the fog , because originally that area was an old industrial area from the 19th century with heavy pollutions from chemicals and heavy metals both in the lake and the ground collected from more than a centurys use of the place. Without Olympic games there were no real interest to take the economical burden to clean the area and restore the environment. Further more there was a lack of practical knowledge how to clean natural waterdeposits and ground from all the different chemicals and heavy metals. This subsidy then came in the right time for the Stockholm City.

A special office was established to complete the applications which should be adressed to the Ministry of Environment. The application involved not only the area at the Hammarby Sjö but also two other districts built some thirty years ago. The last two needed upgrading ssince the energy efficiency of the buildings had to be improved as well as the infrastructure and traffic solutions. Regarding the Hammarby Sjö area it was a matter of making it possible for inhabiting at all. Still the propsed measures for the subsidy included reduced use of energy in the habitat with at least 50%, more efficient use of waste and a strong reduction of Carbon dioxide and other emmisions causing Global Warming and other environmental damages. Even energy autonomi were discussed but not really proposed since the Stockholm City subsidiary company Stockholm Energi AB owned a number of Hydropower plants and because of this the City was in a way regarded as energy autonomous.

To make the story short – the Stockholm City was granted 600 Million SEK, around 10 % of the total national subsidy and the planning of the Hammarby Sjöstad could start.

One of the important improvement resulting from this project has been the Hammarby Model of Eco-cycling. This is an infrastructure model regarding combining energy supply, water and drainage supply and waste – management systems and based on and compliant with the principle of the locally as-close-as-possible ecocycling of water, energy, and other resources. This model havs been very succesful and has created a number of followers all over the world. A result corresponding to one of the initial wishes from the Ministry of Environment.

This scheme shows the recycling processes and their interconnections for energy, waste and water&sewage.

#### For energy :

- Combustible waste is used to generate district heating and electricity.
- Biofuels are used to generate district heating and electricity.
- District heating and cooling are both produced using the purified wastewater.
- Solar energy is converted into electrical power or used to heat water. Electricity should bear the Good Environmental Choice label, or equivalent.
- Biogas is extracted from sewage sludge and food waste.

#### For waste:

- Combustible waste is used to generate district heating and electricity.
- Food waste is biodegraded to produce biogas that fuels vehicles, whilst the mulch becomes nutrient rich fertilizer.
- All material that can be recycled is sent for recycling ; newspapers, cardboard, glass, metal , etc.
- Hazardous waste and electrical waste is recycled or incapsulated.

#### For water&sewage:

- Rainwater from the streets are treated locally and hence does not burden the wastewater treatment plant.
- Rainwater from courtyards and roofs is led off into Hammarby Sjö.
- Wastewater is treated and then helps in the production of district heating and cooling.
- Biogas is extracted from biodegraded sewage sludge.
- The biodegraded sludge is used as a fertilizer.

From this Eco-cycling model it is easy to see that the Hammarby Sjöstad has a combination of nearly all of the technologies that is necessary for an energi autonomous urban area. What is lacking is windpower and geothermal energy conversion. (Both windpower and quite a large number of solar cells were initially planned but the windpower was rejected for environmental reasons and the installation of solarcells because of esthetical reasons.) Geothermal energy was at that time not thought of being enough efficient and cost effective.

The Eco-cycling model is a good model for a sustainable infrastructure based on recycling but there are two more nececities that mark an energy autonomous urbanisation and those are use of renewable energi technologies for heating, cooling and electricity production and last but not least, buildings that produces energy instead of using energy. For this there is another need of shift of paradigm, namely the architectural shift. In Hammarby Sjöstad the buildings are conventional with no intention to be energy autonomous or even a part of an energy autonomous cityscape.

## ENERGY AUTONOMOUS URBANISATIONS IN EMERGING ECONOMIES

The main difference between the urbanisation or expansion of cities in the industrialised western world and the developing world is that the process in the western world is within an established and functioning infrastructure for distribution of energy while in the developing countries there is none such infrastructure or a rather weak infrastructure not only regarding the distribution of energy. In the western world the increase of population in cities are a lot slower then in the developing countries and the newly urbanised areas can rather easy be connected to existent infrastructures. That is not the case in most of the developing world.

Usually the inflow of people to the cities is faster than the building of an infrastructure dimensioned for the number of people inhabiting the areas. There is also a tendency to separate the infrastructures regarding the handling of waste, water&sewage and distribution of energy. Especially since some of the infrastructures are regarded as more valuable or profitable from commercial point of view than others or what gives the fastest pay back. This situation occurs in many countries because the development of infrastructures are handed over from the public interest to the private interests mainly because of the need for financing. This, unfortunately, leads in many cases to a suboptimisation of the investments.

Instead it would be more beneficial, even for the investors, to have a holistic view on the investments based on the Eco-cycling model. This added with an adequate combination with renewable technologies suitable for the location will guarantee the secure distribution of energy which is the demand and right for the inhabitants.

The choices and dimensioning of the different types of renewables in the package is a matter of the geographical location and the microclimate in the area. Relating to this, the building structures should be adapted to the local climatic conditions. This does not mean that so called traditional building modes since the beginning of time should be the model. Only that instead of copying traditional buildings in the western societies where exaggerated use of energy for the climatisation of the buildings compensated for a bad adaptation, or no adaptation at all, to the local conditions, using modern technologies to achieve energy producing houses.

Adapting this thinking may not only give emerging economies and developing countries energy autonomous cities and buildings but also a locally developed and autonomous building industry using locally developed technologies for energy production based on renewable energy sources.

In view of the looming and environment crisis there is no doubt that there is no time to waste.





# Prof. Dr. Tai Sik Lee, South Korea



## Sustainable Engineering for Extreme Environments – Earth & Space

Korean Federation of Engineering Organizations

E-mail: [cmtsl@hanyang.ac.kr](mailto:cmtsl@hanyang.ac.kr)

### ABSTRACT

Climate change is the vital signs of the planet. It is the most complicated issue facing world community. Science and engineering communities developed various technologies to deal this issue. Moreover we have to prepare increase on natural disasters and lack of energy resources such as fossil fuels. To solve this problem research on sustainable engineering on extreme environments has started. The research focus on how mankind can live on limited, uncontrollable, and unacquainted environments and on how they can develop new resources on these environments. Therefore Extreme Engineering is about how mankind can overcome extreme environments such as deep sea, desert, poles, and space.

The reasons why mankind seek extreme environments are 1) frontier spirit which is a nature of mankind to explore new world like climbing Mount Everest, 2) discover and develop new energy resource which are lack on Earth, 3) preparing new settlement for the worst case which we can find from science fiction. It is similar to Columbus voyage to the New World that impact in the historical development of the modern western world.

Especially, space exploration is not a problem of few countries. It is different from the Cold War era which USA and Soviet Union raced on Moon exploration. Recently more than 50 countries are investing on space exploration. It requires worldwide participation as it includes political, financial matter and it will lead to humankind prosperity. The WFEO also need to prepare the space era.

## INTRODUCTION

Climate change is the vital signs of the planet. It is the most complicated issue facing world community. Science and engineering communities developed various technologies to deal this issue. Moreover we have to prepare increase on natural disasters and lack of energy resources such as fossil fuels. To solve this problem research on sustainable engineering on extreme environments has started. The research focus on how mankind can live on limited, uncontrollable, and unacquainted environments and on how they can develop new resources on these environments. Therefore Sustainable Engineering for Extreme Environments for both Earth and Space, which we call "Extreme Engineering", is about how mankind can overcome extreme environments such as deep sea, desert, poles, and space.

The reasons why mankind seek extreme environments are 1) frontier spirit which is a nature of mankind to explore new world like climbing Mount Everest, 2) discover and develop new energy resource which are lack on Earth, 3) preparing new settlement for the worst case which we can find from science fiction. It is similar to Columbus voyage to the New World that impact in the historical development of the modern western world.

Especially, space exploration is not a problem of few countries. It is different from the Cold War era which USA and Soviet Union raced on Moon exploration. Space exploration requires worldwide participation as it includes political, financial matter and it will lead to humankind prosperity.

## NEED OF SUSTAINABLE ENGINEERING FOR EXTREME ENVIRONMENTS

Global warming, raising oil prices, shortages of rice and fish, etc. have shown us that the world has to look for new ways to sustain its future development and growing population. Recent devastating tsunamis, hurricanes and disastrous floods showed that we still do not understand the key mechanisms of the earth nor are we able to engineer sufficient protections. As many scientists have pointed out, the main obstacles are the lack of knowledge about the basic "life-cycles" that can only be gained by exploring those extreme areas of the world that are still not accessible to the eyes of the scientists. Parallel to exploring the extreme regions of this planet we also need to better understand the universe with the closest object being the moon. Korea as well as other nations put their sights on developing exploration outposts on the Moon in the near future. However, the engineering knowledge necessary to build those outposts does not exist. We still depend on the little we learned from the US Apollo landings.

Exploring extreme environment with sustainable infrastructures requires an extreme engineering approach. The first main hurdle, which has been passed for traditional engineering problems, is the lack of engineering knowledge needed to design and plan. These standards and rules have to be established through multi-faceted theoretical and experimental research. Extreme engineering requires international and interdisciplinary collaboration because of the complexity of the intertwined issues and the size of the problems.

## EXTREME ENGINEERING

Opening the new frontiers in the ocean, polar, desert and space requires safe and self-sufficient homes and work areas for many explorers. At this time, we do not know how to build such sustainable habitats. Before the world is able to learn more about the earth, we need to learn how to design, build and maintain shelters for the scientist to observe measure and experiment in those extreme environments. The fact that we do not know how to do these things today implies that this is a non-trivial problem requiring a new approach to research and engineering. Therefore, successful exploration to the new pioneers requires understanding the new environment, derive equipment concepts based on the new environment, develop and test on analog test-bed, and modify.



Figure 1 Unique Features of Extreme Environment

Next are some examples of extreme engineering potential research area.

The research necessary to establish habitats and plant in extreme environment will force new thinking and new concepts. For example, the remoteness of the places, far removed from easily accessible sources of power, will require to design and build energy-poor facilities.

Extreme environments are expected to have different type of resources which are not familiar to traditional resource development. Accordingly, the various technologies accumulated in the process of developing the knowledge to design and build in the extreme environments will be fundamental in the sustainable development of those resources.



# Dimitar Natchev, Maria Stefanova, Bulgaria

## Standards for Sustainable Construction

Bulgarian Institut for Standartization,  
Chamber of Engineers in the Investment Design, Sofia

E-mail: [d\\_natchev@kiip-sofia.com](mailto:d_natchev@kiip-sofia.com) / [m\\_stefanova@kiip-sofia.com](mailto:m_stefanova@kiip-sofia.com)



### ABSTRACT

During the last years international, European and national standardization bodies have developed sustainable construction related normative. This normative will be reviewed in the presentation.

The CEN/TC 350 "Sustainability of Construction Works" has already developed standards related to sustainability works and is developing other indicators related to the same issue. The overall aspect of the sustainability (environmental, economical and social) is taken into account.

ISO TC59/SC17: Building Construction/Sustainability in Building Construction has published several ISO standards addressing the development of indicators for buildings, environmental declaration of building products and methods of assessment for environmental performance of construction works .

Existing methodologies for assessing the sustainability of buildings are partially based on existing standards. There is not yet common European standards regarding construction sustainability and the existing assessment methodologies are developed for their own countries, based on special climatic and political initial conditions and different calculation tools and standards

The lack of a common European standard makes it harder to develop a common methodology or tool for assessing the sustainability at a European level.

## I. STANDARDS, STANDARDIZATION BODIES, EUROPEAN STANDARDIZATION

**Standards** are voluntary documents that define technical and quality requirements with which current or future products, production processes, services or methods may comply. Standards result from voluntary cooperation between industry, public authorities and other interested parties collaborating within a system founded on openness, transparency and consensus.

**European Standard (EN)** is a standard that has been adopted by one of the three recognized European Standardization Organisations (ESOs): CEN, CENELEC or ETSI. It is produced by all interested parties through a transparent, open and consensus based process.

European Standards are a key component of the Single European Market. They are actually crucial in facilitating trade and hence have high visibility among manufacturers inside and outside Europe. A standard represents a model specification, a technical solution against which a market can trade. It codifies best practice and is usually state of the art.

After its publication, a European Standard must be given the status of national standard in all CEN member countries, which also have the obligation to withdraw any national standards that would conflict with it. This guarantees that a manufacturer has easier access to the market of all these European countries when applying European Standards and applies whether the manufacturer is based in the CEN territory or not.

**Harmonized Standard** is a standard adopted by one of the European standardization bodies CEN, CENELEC and ETSI on the basis **of a request /mandate/** made by the European Commission in support of its policies and legislation.

A standardisation request (mandate) is a demand from the European Commission to the European standardisation organisations (ESOs) to draw up and adopt European standards in support of European policies and legislation.

**International standard** is a standard that has been adopted by International Organization for Standardization (ISO)

### Relationship between Directives and standards

European Union Directives define 'essential requirements' (e.g. related to health, safety and environment) that products must meet before they can be placed on the European market. In these circumstances, manufacturers may choose any technical solution that fulfils the essential requirements. If they follow the relevant harmonized European Standard(s), they benefit from a 'presumption of conformity' to the essential requirements set out in the Directive. Following a European Standard is therefore the simplest route to accessing the European Single Market and over 480 million consumers. Under an EU Council and Parliament Decision (768/2008/EC), the 'New Approach' has been enhanced and extended to all sectors. This common framework for the marketing of products, with accompanying regulations, is known as 'the goods package'.

Standards are voluntary, consensus-based and as such do not impose any regulations. They provide the test specifications and test methods (interoperability, safety, quality, etc.).

The application of standards is voluntary. However, laws and regulations may refer to standards and even make compliance with them compulsory. In the European Union, Directives, Regulations and other EU legislation may refer to European Standards. In particular, this is the case within the framework of the '**New Approach**' where European Standards are used to provide presumption of conformity to 'Essential Requirements' of the Directives. The 'Essential Requirements' are mandatory. However, products that comply with European Standards cited in the Official Journal of the European Union under a New Approach Directive benefit from a presumption of conformity with the Essential Requirements of that New Approach Directive. A manufacturer that chooses not to follow the given standards then has the obligation to demonstrate conformity with the Essential Requirements of the Directive.

**New Approach Directives** are based on the following principles.

- Harmonisation is limited to essential requirements.
- Only products fulfilling the essential requirements may be placed on the market and put into service.
- Harmonised standards, the reference numbers of which have been published in the Official Journal and which have been transposed into national standards, are presumed to conform to the corresponding essential requirements.
- Application of harmonised standards or other technical specifications remains voluntary, and manufacturers are free to choose any technical solution that provides compliance with the essential requirements.
- Manufacturers may choose between different conformity assessment procedures provided for in the applicable directive.

European **standardisation is a policy tool** within various domains in support of EU legislation and policies. Up to now standardisation has been used most frequently within the area of Free Movement of Goods to support harmonisation legislation for various products and product groups. As set out in several flagship initiatives supporting the **Europe 2020 Strategy for smart, sustainable and inclusive growth** European standardisation will in future play a bigger role ranging from supporting European competitiveness, protecting the consumer, improving accessibility of disabled and elderly people to tackling climate change.

Standardisation is an integral part of the EU's policies to carry out 'better regulation' to increase competitiveness of enterprises and to remove barriers to trade at international level. At the same time, it attracts public awareness to the challenges standardization is currently facing in a globalised economy.

European Standards are drafted in a global perspective. CEN has signed the 'Vienna Agreement' with the International Organization for Standardization (ISO), through which European and international standards can be developed in parallel. About 30 % of the ENs in the CEN collection are identical to ISO standards. These EN ISO standards have the dual benefits of automatic and identical implementation in all CEN Member countries, and global applicability.

*A Strategic vision for EU Standards. Moving forward to enhance and accelerate the sustainable growth of the European economy by 2020 COM(2011)3111*

**European standards and standardisation are very effective policy tools for the EU.** They are used as policy instruments to ensure the interoperability of networks and systems, a proper functioning of the Single market, a high level of consumer and environmental protection, and more innovation and social inclusion.

**Standardisation processes should be accelerated, simplified and modernised.** It is essential for the European economy that **European standardisation further adapts to the fast changing global landscape and economic environment.**

**Standardisation will play an important part in supporting the Europe 2020 Strategy for smart, sustainable and inclusive growth,** as set out in several flagship initiatives.

**Standards can help to bridge the gap between research and marketable products or services**

The **benefits of standards for the European industry** are tremendous. The most important economic benefits of standards is that they increase productive and innovative efficiency.

In the twenty-first century Europe faces a number of strategic challenges, in particular in areas where standards have particularly strong potential to support EU policy, such as consumer protection, accessibility, climate change, resource efficiency, security and civil protection, protection of personal data and individuals' privacy.

European standardisation can support legislation and policies on **climate change, green growth and can promote the transition to a low carbon and resource efficient economy**. Standards encourage resource efficiency by integrating requirements related to end-of-waste criteria, durability and recyclability.

The foundations of the single market are the four freedoms of movement: of persons, goods, services and capital. In one of these areas, goods, the European standardization system has already made an important contribution, principally by means of the “New Approach” to legislation, designed to prevent the creation of technical barriers to trade.

Standards have an important role to play in **supporting the competitiveness of European businesses in the global market**.

**Standardisation bodies based in the EU should therefore continue to put forward proposals for international standards** in those areas where Europe is a global leader to maximise European competitive advantage. International standardization will also be important in tackling societal challenges, such as climate change, accessibility and the living conditions of an ageing population.

## II. SUSTAINABLE CONSTRUCTION

Sustainable construction has in recent years been a major focus of attention. Governments, market parties and scientists alike undertake and write about various initiatives, experiments and approaches that aim at limiting the construction sector’s impact on our natural environment. /‘Sustainability’ is an over-used buzzword.

By Sustainable Construction, we mean: the practice of creating structures and using processes that are environmentally responsible and resource-efficient throughout a building’s life-cycle from initial planning approval to design, construction, operation, maintenance, renovation and deconstruction. This practice expands and complements the classical building design concerns of economy, utility, durability, and comfort. Sustainability is considered from an ecological, economical, social, functional and technical point of view.

*A more recent definition by the European Commission from 2007:*

*“Sustainable construction can be defined as a dynamic of developers of new solutions involving investors, construction industry, professional services, industry suppliers and other relevant parties towards achieving sustainable development, taking into consideration environmental, energy, socio-economic and cultural issues. It embraces a number of aspects such as design and management of buildings and constructed assets, choice of materials, energy use, the physical and functional performances of as well as interaction with urban and economic development and management. Different approaches may be followed according to the local socio-economic context; in some countries, priority is given to resource use (energy, materials, water, and land use), while in others social inclusion and economic cohesion are the more determining factors.”*

Sustainable construction is the responsible approach towards environment and the reasonable spending of limited resources.

The significance of these topics increases not only at national but also at European level. In this respect chartered engineers and consultants carry special responsibility.

In this respect chartered engineers and consultants carry special responsibility.

Taking into account the globalization and climate change as framework modifying factors, they face the task to create optimal conditions for life and work in buildings and in the same time to avoid or bring to minimum the possible negative effects on environment. It is their duty to produce plans in conformity to the principles of sustainable construction and offer long-term technical and economically optimal decisions.



## European policy and legislative developments

### EUROPE 2020 - A strategy for smart, sustainable and inclusive growth

"Europe 2020: a strategy for smart, sustainable and inclusive growth"

**Sustainable Development Strategy of the European Union (EU SDS)** is a framework for a long-term vision of sustainability.

In simple terms sustainability is living forever from nature without hurting it. Long-term, our chosen energy options must be sustainable, because energy is essential for services such as warmth (in buildings), mobility (transport) and mechanical power, lighting and electronics (from electricity). It is also essential for obtaining materials, by mining and refining, synthesis, and recycling.

Sustainable Development stands for meeting the needs of present generations without compromising the ability of future generations to meet their own needs – in other words, a better quality of life for everyone, now and for generations to come. It is an overarching objective of the European Union set out in the Treaty, governing all the Union's policies and activities. It is about safeguarding the earth's capacity to support life in all its diversity and is based on the principles of democracy, gender equality, solidarity, the rule of law and respect for fundamental rights, including freedom and equal opportunities for all. It aims at the continuous improvement of the quality of life and well-being on Earth for present and future generations. To that end it promotes a dynamic economy with full employment and a high level of education, health protection, social and territorial cohesion and environmental

In July 2009 the Commission adopted the **2009 Review of EU SDS**. It underlines that in recent years the **EU has mainstreamed sustainable development into a broad range of its policies**. In particular, the EU has taken the lead in the fight against climate change and the promotion of a low-carbon economy.

#### EU SDS key objectives:

##### *Environmental protection*

Safeguard the earth's capacity to support life in all its diversity, respect the limits of the planet's natural resources and ensure a high level of protection and improvement of the quality of the environment. Prevent and reduce environmental pollution and promote sustainable production and consumption to break the link between economic growth and environmental degradation.

##### *Social equity and cohesion*

Promote a democratic, socially inclusive, cohesive, healthy, safe and just society with respect for fundamental rights and cultural diversity that creates equal opportunities and combats discrimination in all its forms.

##### *Economic prosperity*

Promote a prosperous, innovative, knowledge-rich, competitive and eco-efficient economy which provides high living standards and full and high-quality employment throughout the European Union.

##### *Meeting international responsibilities*

Encourage the establishment and defend the stability of democratic institutions across the world, based on peace, security and freedom. Actively promote sustainable development worldwide and ensure that the European Union's internal and external policies are consistent with global sustainable development and its international commitments.

The EU's integrated climate and energy policy and an integrated approach to the sustainable management of natural resources, the protection of biodiversity and ecosystem services and sustainable production and consumption are among the drivers for achieving objectives under both the SDS and the Lisbon strategy.

#### Lead Market Initiative for Europe /LMI/

The Commission adopted in Dec. 2007 the communication on the **"Lead Market Initiative"** concerning a coordinated and concerted action to facilitate the **emergence of innovative products and services** in six areas (eHealth, protective textiles, sustainable construction, recycling, bio-based products and renewable

energies). Lead markets should provide solutions to economic and societal challenges such as health, energy, environment and transport.

### **Sustainable construction has been chosen as one of the six.**

The initiative aims to stimulate innovation and improve the sustainability of construction by addressing legislation, public procurement and standardisation, labelling and certification.

### **An integrated life-cycle-oriented approach**

Sustainable construction is one of the six markets in the Lead Market Initiative. It involves environmental concerns, health aspects and issues of convenience. Buildings account for the largest share of the total EU final energy consumption (42%) and produce about 35% of all greenhouse emissions.

### **The Sustainable construction sector**

Sustainable solutions in residential and non-residential buildings as well as in infrastructure constructions are included in this market area. It involves for example efficient heating installations, in-door air quality systems and issues related to elderly persons' independence. The construction market accounts for 10% of GDP and 7% of the workforce. More than 50% of all materials extracted from earth are transformed into construction materials and products. The sector is responsible for 30% of the global CO<sub>2</sub> emissions.

The construction sector exercises a wide influence on the rest of society, playing a central role in the major challenges currently facing us, including the economic crisis, energy efficiency, the need to find a more sustainable development and consumption path, health and safety, etc. This influence is also reflected in the wide variety of actions undertaken by the Commission that impact, directly or indirectly, on the construction sector.

The construction market is currently facing significant challenges, not only in terms of its influence on energy and climate change, but also in terms of its impact on natural resources (energy, water and materials) and users' convenience and welfare (accessibility, safety & security, indoor air quality, etc.). This is particularly relevant for the existing building stock which has a significant socio-cultural value for the society and at the same time accounts for by far the most carbon emissions and the greatest energy saving potential.

On 31 July 2012 the European Commission presented a strategy to boost the construction sector, in which the Eurocodes, a set of European standards for the design of buildings and other civil engineering works, play a key role. The Eurocodes strengthen the competitiveness of the sector, by helping European construction companies to work with greater ease in other Member States.

As a consequence of the financial and economic crisis and the housing bubble, building and infrastructure work fell by 16% between January 2008 and April 2012 across the EU-27. The strategy presented by the Commission proposes several initiatives to support the sector, including measures to make European construction companies more competitive both within the EU and on the global market through the further promotion of the Eurocodes.

Since 2010 the Eurocodes have reached the final stage of national implementation by the Member States as they are now replacing all national standards, assuring more uniform safety levels for buildings and critical infrastructures within the EU, although each country has the option of adapting the Eurocodes to their specific conditions and risk assessment regarding climate, seismic risk, traditions, etc.

At the end of February 2012 two draft mandates covering development of Eurocodes for glass products and improvement of existing Eurocodes, were almost finalized.

JRC proposed Eurocode Help Desk being developed in conjunction with CEN. It will be an IT platform for consolidating feedback on queries on EN Eurocode.

The roadmap (action plan) presented in the LMI Communication (Annex 1) outlined 11 actions, articulated around **3 core objectives**:

- Making the regulatory and standardisation framework for sustainable construction more coherent
- Developing a culture for innovation and Life Cycle Costing in Public Procurement
- Improving the functioning of the supply and the collaborative environment with customers

#### Construction topics:

- Legislation
- Standardisation, Labelling, Certification
- Green Public Procurement
- Life-cycle Assessment in Construction
- Life-cycle Assessment in Construction
- Life-cycle Costing in Construction
- Energy Efficiency in Buildings

Standardization has been identified as a key contributor to development in this area. CEN Technical Board (BT) has therefore set up a BT Working Group: BT/WG 206 - CEN contribution to the EC lead market initiative on sustainable construction - to identify the possibilities for improving the coherence, consistency and comprehensiveness of the portfolio of construction standards in the interests of sustainable construction.

After more than two years of activities, CEN/BT WG 206 has submitted its [final report](#) to the CEN BT identifying 7 actions needing further attention. In addition to the final report, BT/WG 206 also developed a report providing the [strategies for meeting the Construction Performance Requirements](#)

#### The recommended actions are:

*Action 1: CEN TCs should continue to review the needs for new standards within their scope, not restricting themselves to areas regulated under the CPD/CPR.*

*Action 2: A working group should be established by the CEN Construction Sector Network as a new project to explore urgently the needs and possibilities for new process standards that affect all aspects of performance of construction work.*

*Action 3: The Commission and CEN need to seek joined-up thinking in the field of sustainability and ensure the recognition of existing standards as far as possible.*

*Action 4: CEN Technical Committees responsible for standards for design should develop a consistent approach for demonstrating compliance with the BWRs, using relevant aspects of the methodology of the structural Eurocodes, particularly a "head" standard.*

*Action 5: Guidance should be developed by the CEN Construction Sector Network, in conjunction with CEN/TC 350, to ensure consistency between product standards and the standards for assessment of sustainable construction.*

*Action 6: The development of BIM (Building Information Modelling) should be encouraged. The basic standards for BIM are under development in ISO/TC59/SC13, and all members of CEN are asked to take an active part in this committee.*

*Action 7: CEN/BT is invited to consider revising the scope of CEN/BT/WG 206 to monitor and encourage attainment of the recommended Actions 1-6.*

BT/WG 206 final report was approved 2010 and the group has been maintained for a further 2 years period (under the revised scope: 'implementation of the CEN contribution to the EC lead market initiative on sustainable construction'), to monitor and encourage attainment of the recommended actions.

The formal phase of the Commission's Lead Market Initiative has been completed and an independent evaluation carried out of the six areas for initiative, including sustainable construction.

The two Actions on which most discussion is envisaged are Action 2 **on potential needs for new process standards** and Action 5 on guidance **for implementing standards from TC 350 in product standards**.

There is considerable urgency in completing and promulgating this guidance so that we can achieve a **consistent implementation of EPDs for products conforming to harmonised standards.**

On Action 3 on the need for coherence between Commission initiatives in the field of sustainability, CEN organized an information meeting (for all sectors) on the Ecodesign Directive on 10 February 2012.

### **EC Directives as a tool for harmonising and improving the sustainable construction regulatory frameworks in Member States of the European Union.**

#### **Directives affecting environment and the field of construction**

- Energy Performance of Buildings Directive (EPBD)
- Ecodesign Directive (energy related products)
- Energy Labelling Directive (energy related products)
- EcoLabelling Regulation
- EcoLabel for Buildings (first priority office buildings)
- Energy Efficiency Action Plan (2007-2012, 2013-2020)
- Green Public Procurement (GPP)
- Construction and Demolition Waste (Waste Framework Directive)
- Lead Market Initiative (on Sustainable Construction)
- Resource Efficiency Roadmap
- Construction Products Regulation (CPR) > **obligatory CE marking of CPs 1st July 2013**
- New: Basic Works Requirement BRCW 7 Sustainable use of natural resources

The [Construction Products Regulation \(305/2011/EU - CPR\)](#) which repeals the

#### **Construction Products Regulation (CPR)**

The new Regulation 305/2011 was approved on 4 April 2011 and came into force on 24 April 2011. The new Regulation repeals the Directive 89/106/EEC for construction products (CPD)

The key aspects affecting standards come into effect on 1 July 2013.

Construction Products Regulation (the CPR) is to ensure reliable information on construction products in relation to their performances. This is achieved by providing a “common technical language”, offering uniform assessment methods of the performance of construction products.

The aim of the Construction Products Directive (CPD), and now its successor Construction Products Regulation, has been to provide the means for satisfying national requirements by the use of harmonised European product standards, and so to remove barriers to trade. Responsibility for regulations for the performance of construction works lies with Member States.

Standards development in CEN for the construction sector has progressed tremendously in the last decade in response to the CPD. Over 400 standards have become harmonised (hEN) by virtue of notification in the OJEU and more are under development. Products placed on the market, and conforming to a hEN, enable construction works such as buildings and bridges to meet national regulations if the products have been properly selected and incorporated into the works. The national regulations must come within the scope of the Essential Requirements of the CPD (or, from 1 July 2013, the Basic Requirements for Construction Works (BRCW) of the CPR).

The two key elements of a performance-based harmonised product standard are the definition of the characteristics required to enable the performance of construction works to be met in all Member States and references to a single test method for measuring the value of each characteristic. As a matter of principle standards do not prescribe the value of these characteristics nor the criteria for deciding on the suitability of a particular product. These are matters for regulations or the user.

Other standards in the CEN construction portfolio deal with matters of design e.g. the structural Eurocodes. Although not necessarily the subject of regulation in the same way as product standards, they provide a common European approach and follow a similar principle of definition and procedure, reference to product standards and the facility to meet the requirements of Member States.

In parallel to these developments new challenges have arisen, firstly with specific environmental concerns and then with the wider subject of sustainability. The current response of CEN lies primarily in the fields of regulated dangerous substances and of assessment of sustainability. However, the same principles of definition and reference apply to standardisation in these fields.

For dangerous substances the aim is to define the relevant types of performance and to establish methods of test applicable to all products. The acceptability of measurements concerning a product will be judged against European or national legal requirements.

### III. CEN TC 350 / ISO TC 59 SC 17

Around the year 2000, the European Commission began to be concerned that the plethora of national environmental schemes across Europe could begin to create technical barriers to trade within the European Union. A formal mandate to CEN (Mandate M350) was issued by DG ENTERPRISE of the European Commission on 29 March 2004.

The stated goal of the Commission (DG Enterprise) was to provide a method for the voluntary delivery of environmental information that supports the construction of sustainable works including new and existing buildings. The proposed route to achieve this goal is was through voluntary Environmental Product Declarations (EPD).

CEN TC350 "Sustainability of Construction work began its work in late 2005.

The standards being developed by the CEN Technical Committee (TC350) are to provide a harmonized, horizontal (i.e. applicable to all products and building types) approach to the measurement of embodied and operational environmental impacts of construction products and whole buildings across the entire lifecycle. The standards are voluntary and will not set benchmarks or levels of performance.

Subsequently, the scope of the standards being developed in TC350 has been extended beyond that of Mandate M350, to include economic performance and social performance of buildings as well as environmental performance.

#### **The work of the Technical Committee 350 (TC350) has been divided into six working groups:**

- CEN/TC 350/TG "Framework"
- CEN/TC 350/WG1 "Environmental performance of buildings"
- CEN/TC 350/WG2 "Building life cycle description" (suspended in July 2009)
- CEN/TC 350/WG3 "Product Level" (EPDs, communication formats etc.)
- CEN/TC 350/WG4 "Economic Performance Assessment of Buildings"
- CEN/TC 350/WG5 "Social Performance Assessment of Buildings"
- CEN/TC 350/WG6 "Civil Engineering works" /November 2011/

CEN/TC350 standards provide the horizontal EN-standardised methodology and indicators for the sustainability assessment of buildings using a life cycle approach in a transparent way.

This is the main principle in the CEN/TC350 standards, because without a long-term perspective and life cycle approach it is not appropriate to refer to sustainability.

Manufacturers give environmental information in a form of Environmental Product Declaration (EPD) according to the unified European method by CEN/TC350 (EN 15804).

For manufacturers horizontal rules in EN 15804 should be implemented into product standards with the possible product-family specific explanatory rules by the product TCs

CEN/TC350 provides the European standardized basket of indicators for sustainable construction ASSESSMENT for building and EPD for product. If a specific indicator is not included in the assessment, it is marked as "INA" (Indicator Not Assessed)

From the regulatory point of view the Indicators defined in CEN/TC350 standards (e.g. in EN 15978 and rEN 15804) should be regarded as the basket of environmental indicators that have an existing European unified method

Environmental indicators defined in CEN/TC350 standards are offering the standardized European indicators with the unified European method for implementation of environmental issues defined in CPR

The assessment methods for environmental, social and economic performance of buildings given in the standards of CEN/TC350 take into account performance aspects and impacts that can be expressed with quantifiable indicators, which are measured without value judgements and which lead to a clear result for each indicator.

This means that the CEN/TC350 standards are purely technical instruments with the performance based approach as this is the basic precondition for a trade barrier free movement of construction products within the Internal Market and in the global market area.

For this reason, these standards do not provide valuation methods and do not set levels, classes or benchmarks for any measure of performance.

Valuation methods, levels, classes or benchmarks may be prescribed in the requirements for environmental, social and economic performance in the client's brief, national building regulations, national application standards, building assessment and certification schemes, etc.

TC350 standards take into account and respond to the EU legal framework, where the EU legal framework covers the same area as CEN/TC350 standards, i.e. environmental performance of construction products and buildings (e.g. Construction Products Regulation, Eco-design Directive for Energy related products, Energy-labelling Directive, Directive for Energy from Renewable Sources, Energy Performance of Buildings Directive, Waste Framework Directive).

**There are a number of key points included in the CEN TC350 standards, i.e. the following:**

- Methodology;
- Object of assessment;
- Levels and benchmark;
- Modularity;
- Comparison of assessments;
- Use of scenarios;
- Indicators.

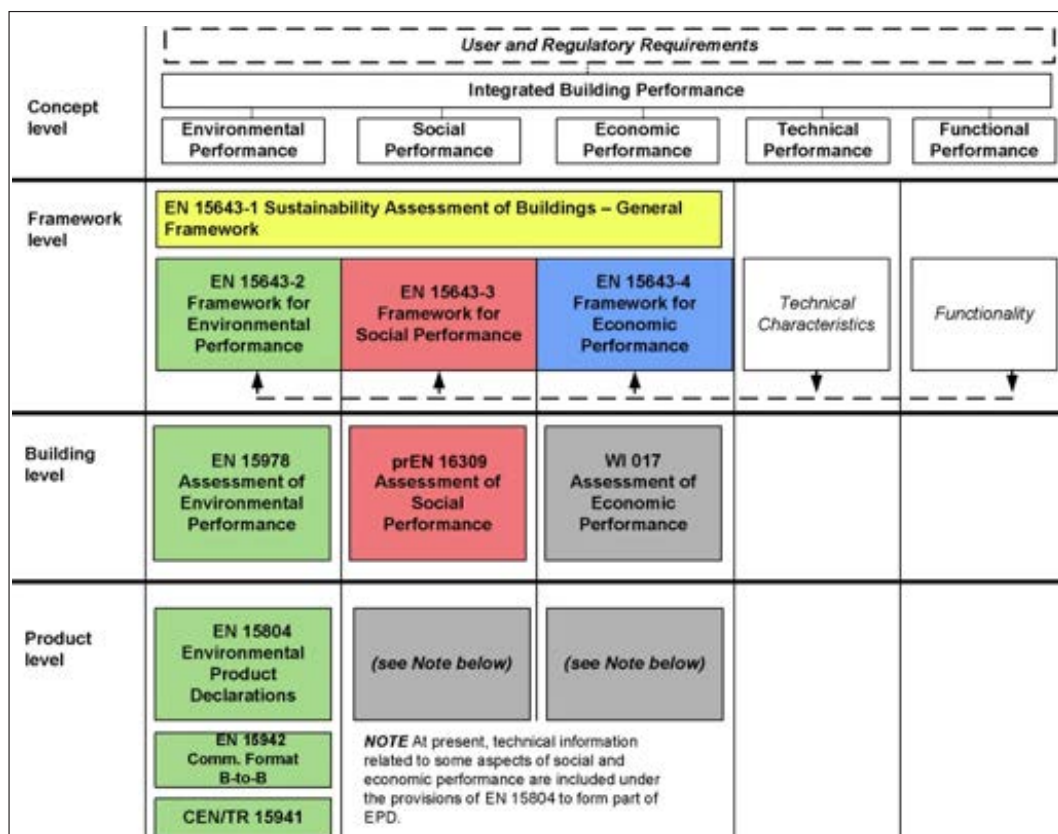

CEN/TC350 Standards package

## Framework level Standards

A framework document (EN 15643-1) and set of three documents based on sustainable pillars (ecology /EN 15643-2/, economic /EN 15643-4/ and social /EN 15643-3/)

### EN 15643-1:2010 Sustainability of construction works - Sustainability assessment of buildings – General framework

This European Standard provides **the general principles and requirements, expressed through a series of standards**, for the assessment of buildings in terms of environmental, social and economic performance taking into account technical characteristics and functionality of a building. The assessment will quantify the contribution of the assessed construction works to sustainable construction and sustainable development.

The framework applies to all types of buildings and it is relevant for the assessment of the environmental, social and economic performance of new buildings over their entire life cycle, and of existing buildings over their remaining service life and end of life stage.

#### general principles:

- The standards (EN 15643-2; EN 15643-3; EN 15643-4), developed under this framework provide a **European system for the assessment** of environmental performance, social performance and economic performance of buildings based on a life cycle approach.

A building assessment system may comprise more than one methodological part: quantifying, analytical part(s) of the method and a valuation part(s) including value judgements. The standards within this framework **only deal with the analytical part**, and for this reason, these standards do not provide valuation methods and do not set levels, classes or benchmarks for any measure of performance.

The assessment methodologies for environmental performance, social performance and economic performance of buildings given in the standards **only take into account performance aspects and impacts that can be expressed with the quantifiable indicators**.

The principles given in Clause 4 are developed into general requirements for the assessment methodology in Clause 5.

- **Relevance of technical and functional performance requirements**

The technical and functional requirements include for example structural safety, fire safety, indoor air quality, security, adaptability, energy efficiency, accessibility, de-constructability, recyclability, maintainability, durability and service life of a building or an assembled system (part of works). These requirements become fixed when they are prescribed in the client's brief or in the project specification.

The technical and functional requirements of the building are taken into account in the description of the functional equivalent.

- **Consideration of building life cycle**

In fulfilling the technical and functional requirements, environmental, social and economic impacts are incurred which extend over its entire life cycle. The building is the source of local, regional and global environmental

- **Objectives of assessment of the building**

- The results of the assessments are expected to contribute to *understanding the impact of the building* and its site. Assessments can provide an opportunity for the client, user and designer to make decisions and choices

- **Approach to assessment of environmental, social and economic performance**

According to the general principles of sustainability in building construction described in ISO 15392:2008, all three dimensions of sustainability of buildings (environmental, social and economic) are all necessary elements in a systemic approach and should be analysed in a systematic way.

This implies that when dealing with the sustainability assessment of a building all three dimensions

of sustainability shall be included in an **integrated assessment of the building's performance**, and communication shall be made accordingly.

Requirements for assessments of the individual dimensions of sustainability are defined in the clause 6 of prEN 15643-2, prEN 15643-3 and prEN 15643-4.

**The functional equivalent** derived from the technical and functional requirements **forms the basis for comparison**. The functional equivalent allows the results of assessments to be provided in a systematic and comparable way. Communication of the assessment results for the environmental performance, social performance and economic performance of a building or an assembled system (part of works) follows the requirements given for communication.

### Requirements for assessment methods

The assessment methodology within this framework shall (as far as possible) ensure that double counting of performance aspects and impacts is avoided.

#### Object of assessment

The building, including its foundations and external works within the area of the building site, is the object of assessments and the source of impacts over its life cycle.

#### Functional equivalent – requirements for basis for comparability

**Comparisons** between the results of assessments of buildings at design stage or whenever the results are used – shall only be made **on the basis of their functional equivalency**.

For sustainability assessment the functional equivalent used in the assessments of the individual dimensions of sustainability shall be identical.

The functional equivalent of a building or an assembled system (part of works) shall include information on the following aspects:

- type and use (required functions);
- area and/or volume;
- pattern of use (e.g. occupancy);
- design life and reference study period;
- location of the building;

#### Type of data and data sources in the assessments

Within this general framework **the building life cycle** starts with the consideration of the need for construction and acquisition of raw materials. It proceeds through the manufacture and procurement of products, construction work processes, actual use including maintenance, refurbishment and operation of the building and finally at the end deconstruction or demolition including reuse, recycling, recovery and disposal of construction materials.

#### Information from these activities is needed to assess the impacts of the building

*Information relating to the object of assessment and the technical and functional requirements shall be taken from the client's brief and from the project specification.*

#### Requirements for communication

##### – Results of the assessment

To ensure that the results of the assessment of environmental performance, social performance and economic performance of a building or an assembled system (part of works) can be understood and interpreted in a transparent and systematic way, **the results of the assessments shall be organized and made available for communication / results from product stage, construction stage, use stage and end of life stages of the building) and expressed with all the defined indicators given in clause 6.2 in EN 15643-2, EN 15643-3 and EN 15643-4 without any further aggregation of the defined indicators.**

Calculation rules and valuation systems for further aggregation of the results of the indicators may be defined in the national standards or schemes according to the national or local preferences.



The results of the assessments shall be organized in the following two main groups of performance results caused by:

- impacts specific to building life cycle excluding operational energy and water use (see 5.6.1.1);
- impacts specific to operational energy and water use (see 5.6.1.2).

– **Functional equivalent**

The technical and functional requirements defined in the client's brief taken into account in the establishment of the functional equivalent of a building or for an assembled system (part of works) shall be declared as part of the communication.

– **Demands for environmental, social and economic performance from client's brief and/or regulations**

If there are requirements for environmental, social and/or economic performance in the client's brief of a building or for an assembled system (part of works), in addition to the technical and functional requirements expressed in the functional equivalent, they shall be declared as part of the communication.

– **Declared technical and functional performance**

**EN 15643-2:2011 Sustainability of construction works - Assessment of buildings –**

**Framework for the assessment of environmental performance**

EN 15643-2 provides the specific principles and requirements for the assessment of environmental performance of buildings taking into account technical characteristics and functionality of a building. Assessment of environmental performance is one aspect of sustainability assessment of buildings under the general framework of EN 15643-1.

The framework applies to all types of buildings and it is relevant for the assessment of the environmental performance of new buildings over their entire life cycle, and of existing buildings over their remaining service life and end of life stage. In this series of standards, the environmental dimension of sustainability is limited to the assessment of environmental impacts and aspects of a building on the local, regional and global environment.

The assessment is on Life Cycle Assessment and additional quantifiable environmental information expressed with quantified indicators. It excludes the assessment of a building's influence on the environmental aspects and impacts of the local infrastructure beyond the area of the building site, and environmental aspects and impacts resulting from transportation of the users of the building. It also excludes environmental risk assessment. The standards developed under this framework do not set the rules for how different building assessment schemes may provide valuation methods. Nor do they prescribe levels, classes or benchmarks for measuring performance. NOTE Valuation methods, levels, classes or benchmarks may be prescribed in the requirements for environmental, social and economic performance in the client's brief, building regulations, national standards, national codes of practice, building assessment and certification schemes, etc. (...)

*The relevant ISO standard: (ISO 21931-1) Framework for Methods of Assessment of Environmental Performance*

**EN 15643-3:2012 Sustainability of construction works - Assessment of buildings –**

**Framework for the assessment of social performance**

This European Standard forms one part of a suite of European Standards and provides the specific principles and requirements for the assessment of social performance of buildings taking into account technical characteristics and functionality of a building. Assessment of social performance is one aspect of sustainability assessment of buildings under the general framework of EN 15643-1. The framework applies to all types of buildings, both new and existing, and it is relevant for the assessment of the social performance of new buildings over all stages of their life cycle, and of existing buildings to their end of life. NOTE 1 Although all stages of the life cycle are considered in this European Standard, the choice of what is practical to cover in the implementation of this framework is the subject of prEN 16309, which is under development. The first version of prEN 16309 may limit the application of the framework to fewer than all life-cycle stages, depending on what methods are appropriate for European standardisation at this time. Future revisions of prEN 16309 will include the assessment of social performance for other stages of the

building life cycle as appropriate methods for measurement are developed and become suitable for European standardisation. The social dimension of sustainability concentrates on the assessment of aspects and impacts of a building expressed with quantifiable indicators. The social performance measures will be represented through indicators for the following social performance categories: accessibility; adaptability; health and comfort; loadings on the neighbourhood; maintenance; safety / security; sourcing of materials and services; stakeholder involvement.

The European Standards developed under this framework do not set the rules for how building assessment schemes may provide valuation methods. Nor do they prescribe levels, classes or benchmarks for measuring performance.

NOTE 2 Valuation methods, levels, classes or benchmarks may be prescribed in the requirements for environmental, social and economic performance in the client's brief, building regulations, national standards, national codes of practice, building assessment and certification schemes, etc. The rules for assessment of social aspects of organisations are not included within this framework. However, the consequences of decisions or actions that influence the social performance of the object of assessment are taken into account.

### **EN 15643-4:2012 Sustainability of construction works. Assessment of buildings.**

#### **Framework for the assessment of economic performance**

EN 15643-4 provides specific principles and requirements for the assessment of economic performance of buildings taking into account technical characteristics and functionality of a building. Assessment of economical performance is one aspect of sustainability assessment of buildings under the general framework of EN 15643-1.

The framework applies to all types of buildings, and is relevant for the assessment of the economic performance of new buildings over their life cycle as well as existing buildings over their remaining service life and end of life stage.

The economic performance assessment of a building addresses the life cycle costs and other economic aspects, all expressed through quantitative indicators. It excludes the economic risk assessment of a building and return on investment calculations. It includes economic aspects of a building relating to the built environment within the area of the building site, it does not include economic aspects beyond the area of the building site, e.g. such as economic impacts of construction of local infrastructure or economic impacts resulting from transportation of the users of the building or economic impacts of a construction project on local community.

The standards developed under this framework do not set the rules for how the different assessment methodologies may provide valuation methods nor do they prescribe levels, classes or benchmarks for measuring performance.

NOTE Valuation methods, levels, classes or benchmarks may be prescribed in the requirements for economic performance in the client's brief, building regulations, national standards, national codes of practice, building assessment and certification schemes, etc. The rules for assessment of economic aspects of organisations, such as management systems, are not included within this framework. However, the consequences of decisions or actions that influence the economic performance of the object of assessment are taken into account.

### **Building level Standards**

#### **EN 15978:2011 Sustainability of construction works – Assessment of environmental performance of buildings – Calculation method**

EN 15978 This European Standard specifies the calculation method, based on Life Cycle Assessment (LCA) and other quantified environmental information, to assess the environmental performance of a building, and gives the means for the reporting and communication of the outcome of the assessment. The standard is applicable to new and existing buildings and refurbishment projects.

The standard gives:

- the description of the object of assessment;
- the system boundary that applies at the building level;

- the procedure to be used for the inventory analysis;
- the list of indicators and procedures for the calculations of these indicators;
- the requirements for presentation of the results in reporting and communication;
- and the requirements for the data necessary for the calculation.

The approach to the assessment covers all stages of the building life cycle and is based on data obtained from Environmental Product Declarations (EPD), their "information modules" (EN 15804) and other information necessary and relevant for carrying out the assessment. The assessment includes all building related construction products, processes and services, used over the life cycle of the building.

The interpretation and value judgments of the results of the assessment are not within the scope of this European Standard.

**Under development:**

**pr EN 16309** Sustainability of construction works - Assessment of social performance of buildings-Methods

**WI 00350017** Sustainability of construction works - Assessment of economic performance of buildings-Methods

**Product level Standards**

**EN 15804:2012 Sustainability of construction works - Environmental product declarations – Core rules for the product category of construction products**

/Relevant ISO standard - EPD of Build. Products (ISO 21930)/

EN 15804:2012 provides core product category rules for all construction products and services. It provides a structure to ensure that all Environmental Product Declarations (EPD) of construction products, construction services and construction processes are derived, verified and presented in a harmonized way. An EPD communicates verifiable, accurate, non-misleading environmental information for products and their applications, thereby supporting scientifically based, fair choices and stimulating the potential for market driven continuous environmental improvement.

EPD information is expressed in information modules, which allow easy organization and expression of data packages throughout the life cycle of the product. The approach requires that the underlying data should be consistent, reproducible and comparable.

This European Standard provides the means for developing a Type III environmental declaration of construction products and is part of a suite of standards that are intended to assess the sustainability of construction works.

This European standard provides core product category rules (PCR) for Type III environmental declarations for any construction product and construction service.

The core PCR:

- Defines the parameters to be declared and the way in which they are collated and reported
- Describes which stages of a product's life cycle are considered in the EPD and which processes are to be included in the life cycle stages
- Defines rules for the development of scenarios
- Includes the rules for calculating the Life Cycle Inventory and the Life Cycle Impact Assessment underlying the EPD, including the specification of the data quality to be applied
- Includes the rules for reporting predetermined, environmental and health information, that is not covered by LCA for a product, construction process and construction service where necessary
- Defines the conditions under which construction products can be compared based on the information provided by EPD.

Type III environmental declarations are defined as:

*"quantified environmental data for a product with pre-set categories of parameters based on the ISO14025, standard - together with ISO14040, 14044, and ISO 21930 (a development of ISO14025 for construction products)*

- with a set of rules including as a minimum: categories of parameters to measured, involvement of interested parties, verification and a declaration format”.

**EN 15942:2011 Sustainability of construction works - Environmental product declarations –  
Communication format business-to-business**

EN 15942 is applicable to all construction products and services related to buildings and construction works. It specifies and describes the communication format for the information defined in EN 15804 for business-to-business communication to ensure a common understanding through consistent communication of information.

NOTE This European Standard does not deal with business to consumer communication and is not intended for that purpose. Business to consumer communication format is planned to be the subject of a future document.

**CEN/TR 15941:2010 Sustainability of construction works – Environmental product declarations –  
Methodology for selection and use of generic data**

This Technical Report supports the development of Environmental Product Declarations (EPD). It assists in using generic data according to the core product category rules (EN 15804) during the preparation of EPD of construction products, processes and services in a consistent way, and also in the application of generic data in the environmental performance assessment of buildings according to EN 15978. The requirements for the use of generic data are described in EN 15804.

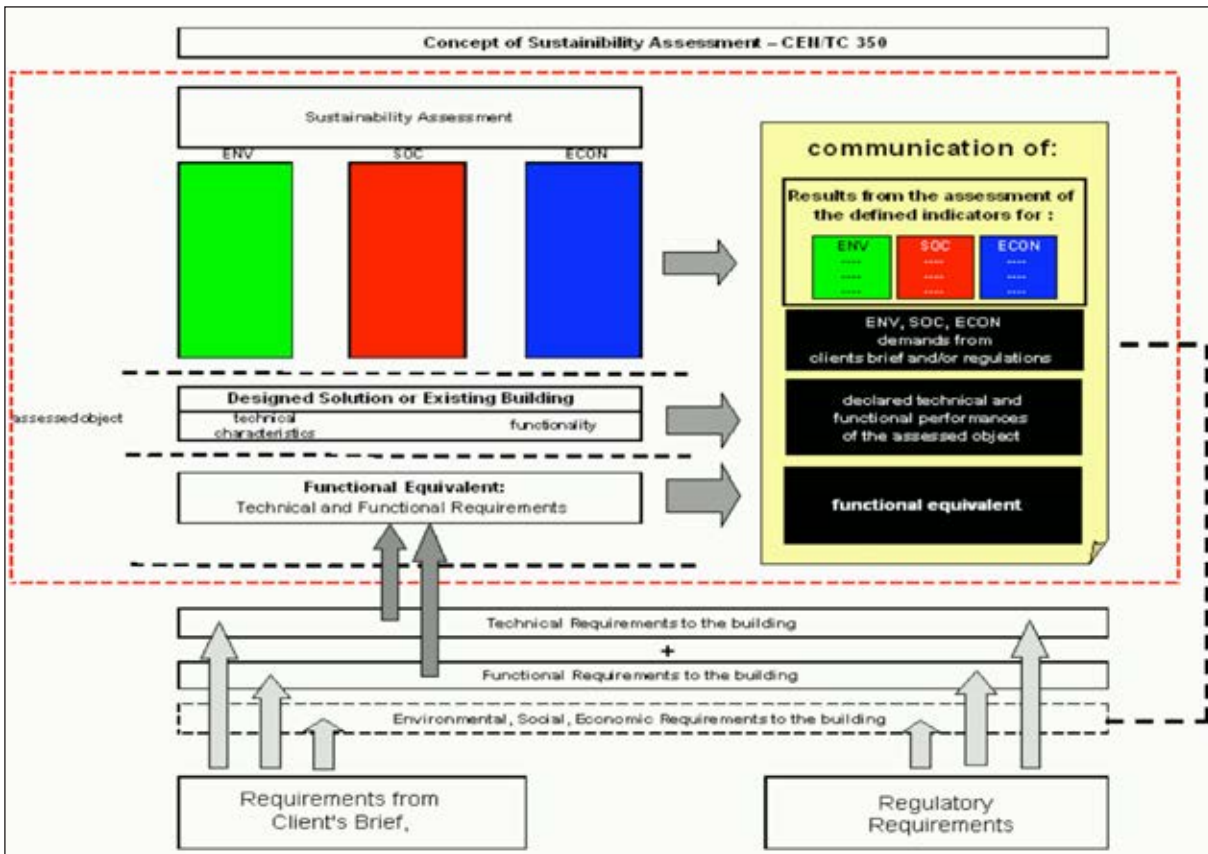

Concept of sustainability assessment – CEN TC 350

Framework level	prEN 15643-1 Sustainability Assessment of Buildings - General Framework (TG)				
	prEN 15643-2 Framework for Environmental Performance (TG)	prEN 15643-3 Framework for Social Performance (WG3)	prEN 15643-4 Framework for Economic Performance (WG4)	Technical Characteristics	Functionality
	Framework for Methods of Assessment of Environmental Performance (ISO/FDIS 21931-1)			Service Life Planning – General Principles (ISO 15686-1)	
Building level	prEN 15978 Assess. of Environ. Performance (WG1)	WI 015 Assessment of Social Performance (WG5)	Assessment of Economic Performance (WG4)	CEN Standards on Energy Performance of Buildings Directive (EPBD)	
	WI 003 Use of EPDs (WG1)		Life Cycle Costing (ISO 15686-5)		
Product level	prEN 15804 Environmental Product Declarations (WG3)	(see Note below)	(see Note below)	Service Life Prediction (ISO 15686-2), Feedback from Practice (ISO 15686-7), Reference Service Life (ISO 15686-8)	
	EPD of Build. Products (ISO 21930)	<b>Note:</b> At present, technical information related to some aspects of social and economic performance are included under the provisions of prEN 15804 to form part of EPD			
	prEN 15942 Comm. Form. B-to-B (WG3)				
	prCEN/TR 15941				

## LIST OF INDICATORS / CEN TC 350

<b>Environmental indicators</b>	<b>Output indicators for assessing the impact</b>	acidification of water and soil
		greenhouse effect
		destruction of the stratospheric ozone layer
		eutrophication photochemical
		formation of tropospheric ozone
	<b>Input indicators of material and energy use</b>	use of non-renewable resources out of primary energy
		use of renewable resources other than primary energy
		use of non-renewable primary energy
		use of renewable primary energy resources
		use of fresh water.
	<b>Output indicators for secondary raw materials, waste and energy exports</b>	materials for recycling
		materials for energy recovery
		Non-hazardous waste to landfills
		hazardous waste to landfills (except radioactive waste)
		radioactive waste to landfills
<b>Economic indicators</b>	<b>Cost</b>	Life Cycle Costs
	<b>Monetary value</b>	Income
<b>Social indicators</b>	<b>Health and comfort</b>	Thermal performance
		Quality of water for use in buildings
		Humidity
		Indoor air quality
		Acoustic performance
		Visual comfort
	<b>Safety and security</b>	Resistance to climate change
		Fire safety
		Security against intruders and vandalism
		Security against interruptions of utility supply (e.g. electricity, water, district heating...)
	<b>Accessibility</b>	Accessibility for people with specific needs (prams, children, etc.)
	<b>Maintenance</b>	Maintenance requirement
	<b>Loadings on neighborhood</b>	Noise
		Emissions
Glare		
Shocks/vibrations		

## International Standardization

### ISO TC59 SC17 - Building construction –Sustainability in building construction

Standards committee ISO TC59 SC17 is responsible for the development of standards relating to the Sustainability of Construction Works, which are among the main precursors to the work of CEN TC350 referred to above. The scope of the work in TC59 covers standardization in the field of building and civil engineering, including:

- general terminology for building and civil engineering;
- organisation of information in the processes of design, manufacture and construction;
- general geometric requirements for building, building elements and component including modular coordination and its basic principles,
- general rules for joints, tolerances and fits;
- general rules for other performance,
- requirements for buildings and building elements including the coordination of these with performance requirements of building components to be used in building and civil engineering; geometric and performance requirements for components that are not in the scope of other ISO TC.

Within this context SC17 is responsible for Standardization related to the built environment in the field of sustainability. This includes environmental, economic and social aspects of sustainability as appropriate.

The working groups of SC17 are as follows:

WG 1: General Principles and Terminology

WG 2: Sustainability Indicators

WG 3: Environmental Declarations of Building Products

WG 4: Framework for Assessment of Environmental Performance of Buildings

WG 5: Framework for the assessment of civil engineering works

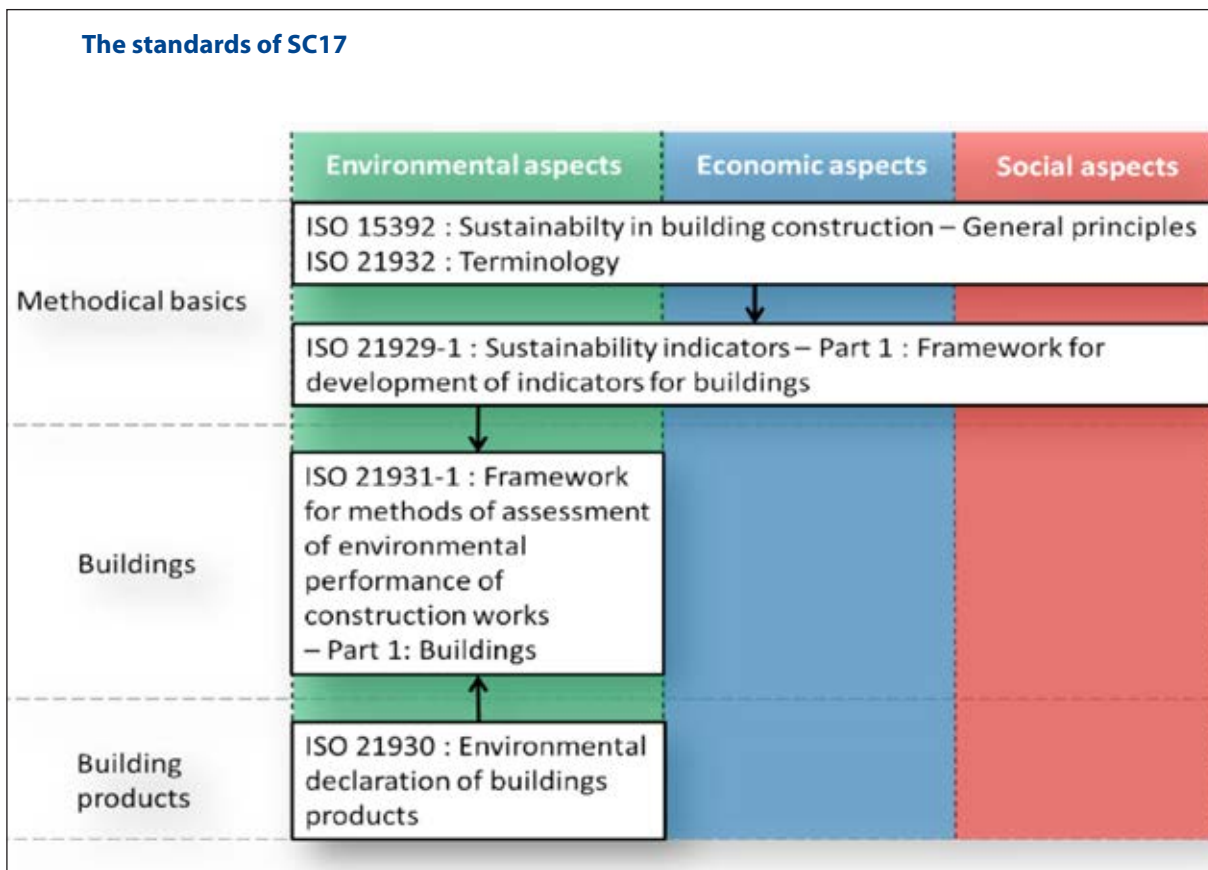

The suite of related International Standards for sustainability in building construction and other construction works is illustrated by the figure adapted from ISO 15392 "Sustainability in building construction: General Principles"[2]:

In the documents released by ISO TC59/SC 17, up to now only environmental indicators are clearly suggested (ISO 21931-1). For social and economic indicators, only recommendations regarding important topics are made (ISO 21929-1). So these social and economic "pillars" of sustainability are not treated sufficiently yet.

Concerning the structure of assessment methods and indicators the ISO 15392 considers the three primary aspects of sustainable development – **economic**, **environmental**, and **social** aspects (with equal importance), while meeting requirements for **technical and functional performance** of the construction works as well in regard to the whole life cycle of building (from their inception to the end of life).

### **ISO 15392 Sustainable building - General Principles**

This standard presents general principles of sustainability related to buildings and other construction works. These general principles form the basis for a suite of standards intended to address specific issues and aspects of sustainability relevant to building and civil engineering of construction works.

The aim of ISO 15392 is to set out the objectives for sustainability in building construction and from these derives general principles, The Standard forms the basis for deriving evaluation criteria and indicators for the assessment of the contribution of buildings to sustainable development and enables decision makers to apply the principles in their decision-making. The standard does not set the political agendas, or provide priorities related to specific concerns, which are established in international agendas, e.g. Agenda 21. However, requirements and targets related to political goals can be related to the identified general principles for sustainability in building construction.

The objectives for sustainable construction the standard sets are:

- improvement of the construction sector and the built environment;
- reduction of adverse impacts while improving value, where impacts as well as value may be judged against any combination of the three primary aspects of sustainability;
- stimulation of a pro-active approach;
- stimulation of innovation;
- decoupling of economic growth from increasing adverse impacts on the environment and/or society;
- reconciliation of contradictory interests or requirements arising from short-term and long-term planning or decision-making.

Principles:

#### **Continual Improvement**

This encompasses the improvement of all aspects of sustainability related to the built environment including the buildings and other construction works over time

#### **Equity**

This principle encompasses the balanced and objective consideration of intergenerational, interregional and intra-societal ethics, including environmental protection, economic efficiency and social needs.

#### **Global Thinking and Local Action**

This principle encompasses the consideration of the global consequences of local actions taking account of local and regional concerns, to ensure that: .

- 1) When acting locally, the regional and global relevance and consequences are considered.
- 2) When establishing and applying global strategies, the local implications, relevance, demands and resources are considered.

#### **Holistic Approach**

A holistic approach addresses all aspects of sustainability over the life cycle of the building or other construction works.



### Responsibility

This principle encompasses the moral responsibility for, rather than legal or financial consequences of, actions carried out by individuals or groups of individuals.

The development of local skills and institutional capacity supports the sustainability of construction works.

### Involvement of Interested Parties

This principle encompasses the taking into account of the contribution and requirements of interested parties relative to their respective areas of responsibility and timing of their involvement.

### Long-Term Consideration

This principle encompasses the taking into account of the short, medium and long term implications in decision-making.

As a minimum it includes the following:

performance over time (as the ability of fulfilling a defined level of function throughout the use phase);

life cycle thinking (i.e. considering the consequences of a choice made in one stage of the life cycle, on the other stages);

legacy – the consideration of the impacts that are handed down as a result of development. The legacy may extend well beyond the physical boundaries of the development.

The legacy can be physical (e.g. the buildings and infrastructure), environmental (e.g. environmental benefit or damage), social (e.g. cultural heritage, skills, capacity building) or economic (e.g. employment, economic growth).

### Precaution and Risk

This principle encompasses the avoidance of risks by applying the precautionary principle, or considering the most unfavorable impacts through risk management:

Precaution (avoidance of risks)

The precautionary principle aims to avoid risks - it sets concerns of future generations as the basis for the analysis of risk potentials.

Risk Management (management of identified risks)

Risk management is a set of coordinated activities including risk assessment, risk treatment, risk acceptance and risk communication.

### Transparency

This principle encompasses the presentation of information in a manner that is open, comprehensive and understandable.

*Note: SC17 WG1 has recently commenced work on a new document which will provide guidance on the implementation of the general principles given in ISO 15932.*

#### **ISO CD 21929-1 Building Construction Sustainability in Building Construction Sustainability Indicators- Part 1 Framework for the development of indicators for buildings and core indicators**

This Standard describes and gives guidelines for the development of sustainability indicators related to buildings and defines the core indicators of buildings.

The framework includes a list of core indicators, which consider the environmental, social and economic impact for levels: location specific indicators, site specific indicators and building specific indicators.

#### **ISO NWI21929-2 Sustainability in building construction – Sustainability indicators Part 2: Framework for the development of indicators for civil engineering works**

This work is still in its preliminary stages and focuses on the development of indicators for civil engineering works.

## **ISO 21930 Sustainability in building construction - Environmental declaration of building products**

The purpose of this standard is to describe the principles and framework for environmental declaration of building products, including consideration of the reference service life of the building products, over a building's life cycle. The standard forms a basis for type III environmental declaration programmes leading to type III environmental declarations of building products as described in ISO 14025.

The standard contains specifications and requirements for the EPD of building products in accordance with the principles and procedures set out in ISO 14025 and ISO 15392. Where the standard contains additional specifications and requirements specific to EPD of building products it complements ISO 14025 for the EPD of building products. In addition, the environmental declaration principles as described in ISO 14020 apply.

The standard provides a framework for and the basic requirements for product category rules (PCR) as defined in ISO 14025 for type III environmental declarations of building products.

The standard, along with ISO 14025, ISO 14040 and ISO 14044, provides the foundation for the TC350 standard EN15804.

According to ISO 21930 the following indicators shall be used to express the impacts and aspects related to building products:

### **Environmental impacts expressed in terms of the impact categories of LCIA**

- climate change (greenhouse gases);
- depletion of the stratospheric ozone layer;
- acidification of land and water sources;
- eutrophication;
- formation of tropospheric ozone (photochemical oxidants).

### **Use of resources and renewable primary energy — Data derived from LCI and not assigned to the impact categories of LCIA)**

- depletion of non-renewable energy resources;
- depletion of non-renewable material resources;
- use of renewable material resources;
- use of renewable primary energy;
- consumption of freshwater.

### **Waste to disposal – Data derived from LCA and not assigned to the impact categories of LCIA)**

The waste allocated to the building product during its life cycle is classified in the EPD as

- hazardous waste, or
- non-hazardous waste.

### **Emissions to water, soil and to indoor air**

Releases to ground- and surface water, as well as emissions to indoor air, are declared in accordance with national standards and practice. Information on human health and comfort due to chemical, biological and physical emissions is required for further evaluation on the building level of human health and comfort.

### **Additional environmental information**

An EPD shall include, where relevant, additional information, such as given in a) to j), related to environmental issues, other than the environmental information derived from LCA, LCI or information modules and other than emissions to water and to indoor air. This information may be:

a) information on environmental issues, such as

- 1) impact(s) and potential impact(s) on biodiversity,
- 2) toxicity related to human health, the environment or both, and
- 3) geographical aspects relating to any stages of the life cycle (e.g. a discussion on the relation between the potential environmental impact(s) and the location of the product system);
- b) data on building product performance, if environmentally significant;
- c) organization's adherence to any environmental management system, with a statement on where an interested party can find details of the system;
- d) any other environmental certification programme applied to the building product and a statement on where an interested party can find details of the certification programme;
- e) other environmental activities of the organization, such as participation in recycling or recovery programmes, provided details of these programmes are readily available to the purchaser or user and contact information is provided;
- f) information that is derived from the LCA but not communicated in the typical LCI or LCIA-based formats;
- g) instructions and limits for efficient use;
- h) hazard and risk assessment on human health and the environment;
- i) information on absence or level of presence of a material in the building product that is considered of environmental significance in certain areas; see ISO 14021:1999, 5.4 and 5.7 r);
- j) preferred waste management option for used building products;
- k) potential for incidents that can have impact(s) on the environment, such as
  - the end-of-life stage, from deconstruction, reuse, demolition, recycling and disposal,
  - energy-, water-saving etc. and other improvements, such as acoustical improvements,
  - energy content of the building product for energy recovery in the end of life,
  - recycled content (see ISO 14021:1999, 7.8.1.1) or recycling rates.

**ISO 21931-1 Sustainability in building construction –  
Framework for methods of assessment for environmental performance  
of construction works – Part 1: Buildings**

This International Standard provides a general framework for improving the quality and comparability of methods for assessing the environmental performance of buildings and their related external works. It identifies and describes issues to be taken into account in the use and development of methods of assessment of environmental performance for new or existing buildings in their design, construction, operation, maintenance, refurbishment and deconstruction stages.

This standard was one of the starting points for the TC350 standards, and follows similar principles, i.e. assessment is based on life-cycle principles, but use a much broader based set of indicators than those include by TC350. The indicators included essentially mirror those found in ISO 21930.

**ISO TR 21932 Sustainability in building construction –Terminology**

This technical report describes the results of work within ISO TC59 to establish consistent terminology for concepts related to the subject field of sustainability in building construction.

Standards of the ISO/TC207 "Environmental management" are the basis for assessment of environmental performance of buildings. A basic tool for assessment of environmental performance is the Life Cycle Assessment (LCA). In communication of environmental information a basic mean is Environmental Product Declaration (EPD). All of the standards of the ISO/TC207 are generic in nature because they can be applied to all materials, products and services.

ISO/TC59/subcommittee 17 is developing standards for assessment of sustainability in the building sector and subcommittee 14 for service life planning of buildings. The ISO TS (technical specification) for framework for methods of assessment for environmental performance of buildings forms a good basis for a horizontal European Standard for the assessment of the environmental performance of buildings. The ISO standard for environmental declaration of building products provides a sounded framework but need to be supplemented with European rules for the environmental product declarations.

As assessment of sustainability of buildings is based on life cycle thinking, it is impossible to assess

environmental or economic performance of a building without having scenarios on the use and durability of products incorporated in the building, i.e. information on the service life of building products in its intended conditions of use. Service life planning provides one of the necessary tools for sustainable design of buildings in terms of technical performance. Standards on this issue from ISO/TC59/subcommittee 14 would be taken into account.

International and European standards propose a common assessment structure based on the three pillars of sustainable development. But the Approaches used by ISO/TC 59/SC 17 differ from the one used by CEN/TC 350.

- At ISO level, it is a framework document with a construction approach then a product one.
- At CEN level, it is a product approach, then a construction one.

ISO and CEN have a different vision to treat the subject:

- At ISO level - A framework document (ISO 15392) and sustainable performance indicators documents (ISO 21929- 1, ISO 21929- 2)
- At CEN level- A framework document (EN 15643-1) and set of three documents based on the three pillars of sustainable development (ecology, economic and social).

Standards have an important role to play in supporting the competitiveness of European businesses in the global market, allowing them to access foreign markets and establish business partnerships around the globe.

The European standardisation system therefore recognises the primacy of international standards, by means of the Vienna and Dresden agreements, which set out the framework for cooperation between the ESOs and international standardisation bodies (ISO)

In order to avoid potential technical barriers to trade with the global perspective, CEN Standards are based, wherever possible, upon the internationally accepted standards of ISO, particularly the ISO existing standards from ISO/TC 59/SC 17 ("Sustainability in buildings"), ISO/TC 59/SC 14 ("Service life planning").

ISO 21930 was one of the starting points for the TC350 standards, and follows similar principles, i.e. assessment is based on life-cycle principles, but use a much broader based set of indicators than those include by TC350.

ISO 21930, along with ISO 14025, ISO14040 and ISO14044, provides the foundation for the TC350 standard EN15804.

#### **Recent European initiatives, concerning implementation of standards for products and sustainability assessment**

*Construction Sector Network Project Environment - CSNPE*

The objective of CSNPE is to provide a forum for discussion and development of environmental topics prior to their possible implementation by the CEN TCs in the construction sector. Its role is essentially advisory and it has a flexible membership.

#### **CSNPE objectives :**

- To focus on the consistency between EPD standards from CEN/TC 350 (EN 15804) and product standards
- To identify the possible guidelines for products CEN/TCs to provide information for EPDs and to help manufacturers to apply EPDs

The current priority of this work is on the interface between product standards and sustainability assessment standards, especially for Environmental Product Declarations (EPD).

CSNPE was identifying guidelines for product TCs to provide information for environmental product declarations carried out according to EN 15804. CSNPE had identified some key aspects to be covered, including systems and scenarios, and it was important for all product TCs to be involved in this work. A first draft was expected mid 2012.

*Commission initiatives on sustainability: industry concerns (BT/WG 206 Action 3\*)*

The Commission seemed to be ignoring the complex relationship between the three pillars of sustainability by just picking up one element. CEN/TC 350 had standardized on 22 indicators. Member States should

define which indicators to use for quantification of sustainability. Under the CPR each BRCW (Basic Requirement for Construction Works) had a few characteristics to be declared, but EN 15804 in addition listed 22 indicators. Construction products are intermediate products, with the final product being the building. Europe is suffering from proliferation of initiatives, with lack of coordination and coherence across the Commission on sustainability. The building defines the need for product information.

*Commission initiatives on sustainability: head standards' (BT/WG 206 Action 4)*

The aim was to develop a set of interoperable standards addressing all BRCWs, as introduced in EU2020 on globalisation and a strategic vision for European standards. Standards therefore had an important role to play. The set of Eurocode standards was described and the use of Nationally Determined Parameters. Head standards already existed for BRCW 1 and 2 (fire part), an umbrella standard for 6, and a framework standard of assessment of sustainability of construction, for which Action 4 of the CEN/BT WG 206 report set some requirements.

The Commission had mandated CEN (M480) to develop a second generation of ENs to support the revised EPBD. The current ENs were not consistently used in Member States, with only 20% to 40% being referenced completely. ENs supporting EPBD were to be revised, to be more usable for direct reference nationally, planned for 2015 – 2020.

To review potential difficulties in relation to data requirements in construction product standards supporting the revised EPBD

*CEN Construction Sector Network Conference on 9/10 June 2011 in Brussels - Interoperability and sustainability for construction*

<http://www.cen.eu/cen/Sectors/Sectors/Construction/Events/Pages/Allpresentations.aspx>

*Construction 2020 - Internal Market for Construction Products, CE marking – Quality construction products for safe works, 25 June 2012*

There should be **more coordination of the various initiatives and policies** at the various levels of the European Commission in many areas, with regard to Green Public Procurement, eco-labelling, ecodesign, recycling, waste management and 'green taxes' and subsidies. It was recommended to introduce an interdisciplinary or holistic approach from inside the Commission. The Commission should talk with one voice, or try at least to communicate the full picture relating the ongoing EU initiatives.

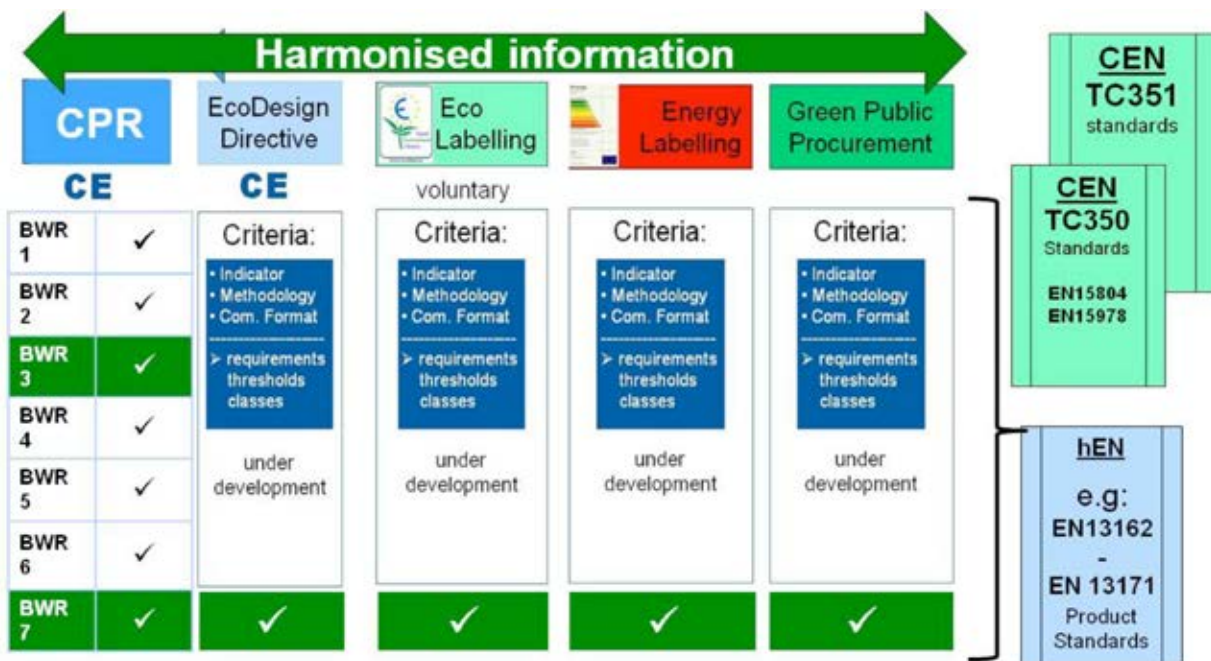

Coherence of EU legislation

## IV. EUROPEAN AND INTERNATIONAL INITIATIVES/PROJECTS

The CEN/TC350 standards provide a consistent framework and approach to collection, calculation and presentation of the data on a range of impacts and aspects for construction products and in the application this data as part of building level assessment.

These standards do not provide valuation methods and do not set levels, classes or benchmarks for any measure of performance. They are tools that can be used within existing national schemes providing a more consistent basis for the 'judgements' on performance that need to be made. The Standards are flexible and provide room for local adjustments.

A number of well-established European rating tools for buildings are applying LCA as a methodology for assessing the environmental performance of buildings: e.g. BREEAM, HQE/Elodie and DGNB/BNB. The Sustainable Building Alliance (SBA) is conducting a pilot study to assess the ability of an even larger number of partners, e.g. members of the World Green Building Council to apply the core indicators of SBA in their tools. These core indicators are based on the European Standards of CEN TC 350. The goal of this pilot study is to apply common indicators for assessing the sustainability performance of buildings in Europe and worldwide based on the European Standards of CEN TC 350.

Many of the countries have a non-governmental organization which aims to improve sustainable construction (e.g. Green Building Councils). The European GBC's work together.

The problem is that sustainability should be reached at a local level, and at the same time you might want to regulate it on a EU-level.

The number of certification systems has surged in the last decade, although their usage remains limited outside the UK and the US. There are four dominant sustainability certification systems for buildings in the World:

- BREEAM (British - BRE Environmental Assessment Method)
- DGNB (German -Deutsche Gesellschaft für Nachhaltiges Bauen)
- HQE (French - Haute Qualité Environnementale)
- LEED (US- Leadership in energy and environmental design).

### BREEAM

The British national tool **BREEAM** stands for BRE **Environmental** Assessment Method for Buildings that went into operation in 1990. There are various versions of BREEAM for different building types (e.g. offices, prisons, education, residential, etc.) and geographical locations (e.g. BREEAM Dutch, Gulf, Europe commercial, ...), but all **versions use a similar basic structure**.

### BNB/DGNB

Bewertungssystem Nachhaltiges Bauen (BNB) is a **German** assessment system for sustainable construction, primarily geared at **public sector buildings** (newly built office and administration buildings). It exists side by side with the DGNB (Deutsches Gütesiegel Nachhaltiges Bauen = German Seal for Sustainable Building) and went into operation in 2009.

### PromisE

PromisE is the **Finnish** environmental assessment and classification scheme for **residential, office and retail buildings**. It includes two systems, i.e. one assessment and classification system for **existing** buildings and one system for **new** buildings. The systems are used for the assessment of the **environmental** performance of buildings and for setting requirements for new buildings. It may lead to certification of the assessed building.

### HQE

The **French** building evaluation and certification tool for buildings HQE (haute qualité **environnementale** du bâtiment) aims at voluntary certification of buildings with outstanding **environmental and energetic**

performances that correspond to actual best practices. The **evaluation concerns the planning, realisation and use phase** of new buildings or major renovation of existing buildings.

HQE is applicable to **newly built and renovated offices** and **education buildings**, as well as to **individual houses** and **multi-residential buildings**. It went into operation in 2005 for tertiary buildings, in 2006 for individual houses and in 2007 for multi-residential buildings.

### Valideo

Valideo is the **Belgian** sustainable building evaluation system. It went into operation in 2008 and is used for the voluntary certification of **new, existing and renovated (office and multiresidential) buildings**.

### LEED

LEED is a national **buildings in the U.S.A.** It is applicable to new and renovated multi-residential buildings, offices, industrial buildings, schools, retail, healthcare and commercial interiors. LEED for homes is a particular version of LEED. LEED went into operation in 1998 and was updated many times since (last update in 2009).

These buildings tools are strategy tools, communication tools. The problem is not to have several systems/labels, but that they **are not interconnected, that they are not comparable**, that they measure things in several ways. That is the problem that the Sustainable Building Alliance is trying to solve by bringing common metrics

Bulgaria: the *Bulgarian Green Building Council (BGBC) certification scheme*. The main goal of the BGBC is the implementation of a national certification system based on the German DGNB's scheme. The BGBC was founded in June 2009 – initiated by private persons, companies (members), and other industry representatives. It was a follow-up of an international initiative. Respondents state that the BGBC's certification scheme "is catching on and is used in a small number of projects". It coexists with government regulation, but there is no direct relation. The scheme sets higher criteria for sustainable construction than formal regulation.

Harmonisation is needed.

With the CEN/TC 350 tools at least everybody can speak the same technical language. But It would be very helpful if all countries calculate their benchmarks on energy consumption, embodied energy, product quality, water consumption, social and economic criteria and so on, in the same way.

In the future there won't be different Green Building certification schemes which are not comparable. There should be one European system.

For an open European market, with contractors working in different countries, there needs to be a uniform European label for sustainability, so that the contractors don't have to study for each member state how to address the sustainability label. The EC currently supports the development of instruments for this.

### Projects supported by the European Commission

LEnSE project (FP6/EC) – Methodology Development towards a Label for Environmental, Social and Economic Buildings – European research project, supported by the European Commission within the Sixth Framework Program and responds to the growing need for assessing a uilding's sustainability performance.

Perfection project (FP7/EC) – European Coordination Action for Performance Indicators for Health, Comfort and Safety of the Indoor Environment – is within the Seventh Framework Program

SuPerBuildings (FP7/EC) "Sustainability and Performance assessment and Benchmarking of Buildings  
OPEN HOUSE (FP7/EC) "Benchmarking and mainstreaming building sustainability in the UE based on transparency and openness from model to implementation"

The main objective of OPEN HOUSE is to develop and to implement a common European transparent building assessment methodology.

The OPEN HOUSE project is closely linked to the SuPerBuildings project. The research and development activities as well as deliverables are exchanged between the projects to avoid duplication of work and to ensure an effective proceeding in both projects.



# **Sustainable Infrastructure**



# Prof. Abubakar Sani Sambo, J.S. Olayande & B.F.I. Sulu, Nigeria



## Estimation of Energy Demand in the Building and Construction Section of the Nigerian Economy

Energy Commission of Nigeria

E-mail: [assambo@yahoo.com](mailto:assambo@yahoo.com)

### ABSTRACT

The construction sector in Nigeria includes activities involving building of residential, commercial, industrial and public buildings. It also involves construction of roads, bridges, canals, airports, sea ports, power and energy facilities, irrigation and water supply facilities, pipelines and railways. In 2010, the value added in this sector was ₦394 billion amounting to 2.1% of the Gross Domestic Product of ₦29,108.0 billion. In the same year, the total final energy consumption by the sector was about 32,500 toe representing 0.11% of the total final energy demand in all the country's economic sectors. With the aspiration of the country to become one of the 20 most developed economies in the world by 2020, the country's infrastructure will have to be substantially transformed. This requires timely energy supply and other inputs. Planning for secured supply of energy in the building and construction sector requires estimation of the energy demand in the sector. The energy demand estimation was carried out using the Model for Analysis of Energy Demand initially developed by the International Atomic Energy Agency. Four economic growth scenarios were considered in the analysis with the reference scenario of 7% growth of GDP per annum showing that total energy demand would amount to about 94.0 million toe by 2020 and 191 million toe by 2030. The projected energy demand for the building and construction sector accounted for 11.10% and 12.50% of the total final energy demand in 2020 and 2030 respectively. A major challenge is how to supply the energy in a sustainable manner.

## 1. INTRODUCTION

The construction sector in Nigeria includes activities involving building of residential, commercial, public and industrial buildings. It also includes construction of roads, bridges, canals, airports, sea ports, power and energy facilities, irrigation and water supply facilities, pipelines, and railways. The construction sector's share of the Gross Domestic Product (GDP) is only 2 per cent. Nigeria along with India is predicted to have higher growth rates than China in construction output between 2009 to 2020 (GCPOE 2010).

Nigeria's government ambition for the country to be among the 20 most developed economies in the world by year 2020 means rapid growth in housing, improving public services, developing tourism sector, improving transportation systems, creating new jobs and eradicating poverty – all these are linked to the construction sector.

Energy utilization in building and construction is an important component of sustainable construction. Sustainable construction entails sustainability in direct energy use, in the amount of fuel used in obtaining the raw materials, and in the production process and transportation of materials. This study only addresses direct energy usage for building and construction. All energy usage for obtaining the raw materials such as mining of limestone for the manufacture of cement which is a major material used in construction is regarded as energy usage in the mining sector. Energy usage for the processing of raw materials such as cement is taken as energy usage in the manufacturing sector while energy usage for the transport of the materials is considered as energy usage for freight transport.

Energy supply infrastructure require long time planning and construction projects span over along period of time, therefore, a twenty-year period has been chosen for this study with 2010 as base year. Four scenarios were constructed based on GDP growth rates, namely, a Reference Scenario which represents the most likely future development of 7%, a High Growth Scenario (10%), Optimistic I Scenario (11.5%) and Optimistic II Scenario (13%) which will launch the country into the group of 20 most developed economies in the world by the year 2020 (Vision 20-2020). The scenarios reflect trends and effects of the government policies and private sector behaviours.

The construction sector in Nigeria contributed about 2% of the GDP of ₦29,108 billion in 2010, whilst the final energy consumed was only 0.11% of the total final energy demand of 32.5 million tonnes of oil equivalent (Mtoe) for the entire economy.

Due to the importance of the subject and the role of precise forecasting of energy demand in energy planning for the construction sector, this paper will provide the estimation of the energy demand of the construction sector of the economy, with special attention to the requirement of the Vision 20-2020 of Nigeria's government.

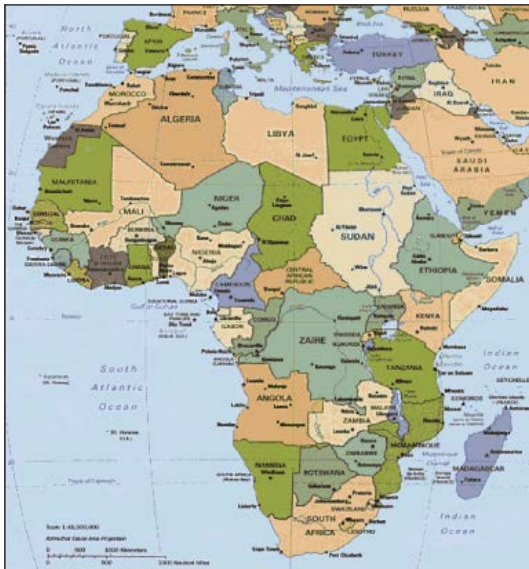

Table 1: Socio-Economic Parameters

<b>Total Area</b>	<b>92.4 million hectares (Land 86%, Water 14%)</b>
<b>Forest and Woodlands</b>	11.6%
<b>Polity</b>	Democracy (Presidential System)
<b>Population</b>	158.80 million (2010)
<b>Economic Indicators</b>	
• GDP growth rate	7.9% (2010)
• Inflation rate	11.8% (2010)
• Interest rate	15.74%, Prime (2010)
• Exchange rate	1\$ = N162 (2012)
• Major contributor to foreign Exchange earnings	Oil (approx. 87.57% in 2010)
<b>Social Indicators (2009)</b>	
• GDP/Capita	\$1,235.92 (2010)
• Energy Intensity	0.1 kgoe/\$
• Energy Consumption/Capita	100 kgoe
• Electricity Consumption/Capita	130 kWh
• Urbanization	40%
• Electricity Access	55.2%
• Population Growth rate	3.2%
• Adult Literacy rate	64%
• Life Expectancy	54 years
• Incidence of Poverty	54%

Apart from this introductory section, the paper contains four other sections: sections 2 and 3 discuss the methodology for conducting the energy demand estimation and, input data, application and results of the analysis respectively. Section 4 is on practical steps on the path to sustainable housing while the concluding remarks are provided in section 5.

## 2. METHODOLOGY

The analysis of the energy demand and projection was carried out using the International Atomic Energy Agency (IAEA) Model for Analysis of Energy Demand (MAED). The MAED allows for the differentiation between energy demand for specific uses and substitutable energy demand. Energy demand is disaggregated into a number of end use categories, each corresponding to a given service or to the production of a certain good in the construction sector. Each main sector was subdivided into a maximum of ten user-defined subsectors. This free split of sectors into subsectors allows for a high flexibility in reflecting the industry structure pattern.

The energy demand of the construction sector is driven by the level of economic activity of the subsector evaluated in terms of its value added and the energy intensity of each energy form. The level of economic activity of construction sector is obtained from the data on total GDP and GDP structure.

For each sector the energy demand is calculated separately for three end-use categories:

1. Electricity for specific uses (lighting, motive power, etc.);
2. Thermal uses (water heating, steam generation, furnace and direct heat);
3. Motor fuels for driving of construction equipment such as bulldozers, excavators, etc.

Of the end-use categories of energy demand considered, motor fuels and electricity for specific uses are non-substitutable forms. On the other hand, substitution possibilities exist for the thermal uses, in particular for the displacement of fossil fuels (mainly oil). For non-substitutable forms (i.e. electricity and motor fuels) energy intensities are specified in terms of final energy per unit of value added, and for substitutable forms (thermal uses) in terms of useful energy per unit of value added.

The required information for the base year have been collected from documents published by the National data producing organizations. The remaining data which are mostly related to entrance data for forecasted year was gathered through extensive survey conducted and utilization of stakeholders' points of views.

## 3. INPUT DATA, APPLICATION AND RESULTS OF THE ANALYSIS

Activities in construction require energy consumption. Energy usage in this sector includes motor fuels and electricity in machinery and motors. It also includes thermal energy for heating asphalt for road surfacing. For calculation of motor fuel, electricity and thermal energy consumption, energy intensity and building and construction value added have been used. All the energy forms were first calculated at the useful levels and then converted to final energy.

Data requirements for the analysis include the GDP for the entire economy and growth rates, sectoral value added and growth rates, total population and population growth rates, energy intensity of each type of energy source, urbanization rates, etc. While the study was conducted for the entire economy only the data that are relevant to this paper are presented and discussed.

Table 2 shows the percentage contribution to the GDP by sectors. While construction accounted for 2.1% of the GDP in 2010, it is projected to account for 5.4%, 5.5%, 5.5% and 5% in the Reference, High Growth, Optimistic I and Optimistic II scenarios respectively by year 2030. These projections were estimates arrived at following consultations with the National Planning Commission.

Table 2: Percentage Sectoral Contribution to GDP

	2010	2020				2030			
	Base year	Ref	HG	Opt I	Opt II	Ref	HG	Opt I	Opt II
Agriculture	41.7	38.0	33.5	33.5	29.0	34.0	27.4	27.4	20.0
Construction	2.1	4.5	4.6	4.6	3.9	5.4	5.5	5.5	5.0
Mining	0.4	0.5	0.5	0.5	0.4	0.6	0.6	0.6	0.5
Manufacturing	4.3	11.0	12.5	12.5	15.0	14.0	19.5	19.5	23.0
Energy	17.4	11.0	9.7	9.7	20.0	8.0	6.0	6.0	12.5
Services	34.1	35.0	39.2	39.1	31.7	38.0	41.0	41.0	39.0
<b>Total</b>	<b>100</b>	<b>100</b>	<b>100</b>	<b>100</b>	<b>100</b>	<b>100</b>	<b>100</b>	<b>100</b>	<b>100</b>

111

Another major input required for the energy demand projection in the construction sector is the intensity of motor fuels, electricity and thermal energy utilization. Spot survey was conducted on some construction companies in the large, medium and small categories in the Federal Capital Territory Abuja where most of the construction works take place at the moment. The survey entailed obtaining the consumption of various energy forms by the construction firms and their annual turnovers in the base year. These data were applied to compute the energy consumption per unit of value added in each firm and an average obtained for the surveyed firms. It must be stated that the motor fuels, electricity and thermal energy intensities were obtained separately. Factors that would shape the evolution of energy intensities in the future were analyzed. These include the efficiencies of the technologies, prices and tariffs of energy carriers, energy conservation and efficiency policies.

Improvements in technologies would tend to reduce the energy intensities while increasing tariffs and prices would force the construction companies to embrace cost saving measures which include minimizing cost of fuel for their operations. Moreover, much manual labour is involved presently, it is therefore, expected that there would be increased penetration of machinery to replace the manual labour. This will increase the energy intensity. Application of thermal energy (for heating asphalt used in road surfacing), the major source of thermal energy application in the construction sector in Nigeria, is currently done in an inefficient manner. It is expected that the technology for the heating will improve, hence a reduction in thermal energy intensity. Table 3 shows the estimates of the energy intensities obtained for the construction sector in Nigeria.

Table 3: Energy Intensities in the Construction Sector, kWh/Naira

Energy forms	2010	2020				2030			
	Base year	Ref	HG	Opt I	Opt II	Ref	HG	Opt I	Opt II
Motor fuels	0.03	1.31	1.31	1.35	1.35	1.52	1.52	1.58	1.58
Electricity	0.018	0.194	0.194	0.200	0.200	0.203	0.203	0.220	0.220
Thermal energy	0.006	0.005	0.005	0.0045	0.0045	0.005	0.005	0.0045	0.0045

## ESTIMATION OF LONG RUN ENERGY DEMAND IN THE CONSTRUCTION SECTOR

The energy demand was first calculated at the useful level and then converted to final energy. Though the MAED model lumps together the useful and final energy demand projections for all industry sub-sectors (agriculture, construction, mining and manufacturing), in this study, we separated energy demand projections for the construction sector from the rest of industry.

The electricity demand for the construction sector is given in Table 3; the consumption of electricity will increase from 0.11TWh in the base to between 12.44 – 27.93TWh in 2030 for the Reference and Optimistic II Scenarios. There is a high increase in electricity demand for the first period; the periodic growth between 2010 and 2015 is about 1,800% for the Reference Scenario to 2,700% for the Optimistic II Scenario (Fig. 2). This increase is due to the massive infrastructural development expected in several sectors of the economy. More power plants, houses, and roads will be constructed for the country to achieve the MDGs and be able to be among the 20 most developed economies by 2020. Subsequently periodic growth decreases with time to about 200% by 2030 for all the scenarios.

Table 4: Final Electricity demand projection in TWh

Scenario	2010	2015	2020	2025	2030
Reference	0.11	2.03	4.94	7.27	12.44
High Growth	0.11	2.37	5.69	9.64	19.27
Optimistic I	0.11	2.87	6.31	12.26	23.65
Optimistic II	0.11	3.02	6.85	14.21	27.93

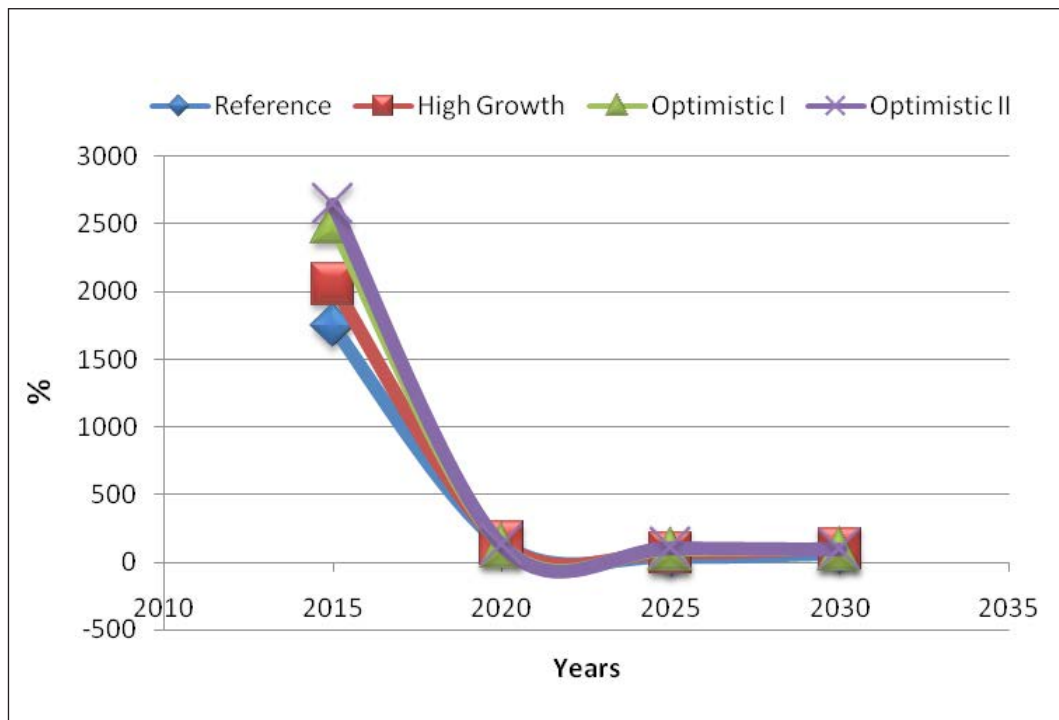

Fig.1 Final Electricity demand projection, TWh



The final motor fuels demand projection for the construction sector as shown in Table 5 that will need about 10 Mtoe by the 2020 and about 33 Mtoe in 2030. To achieve the Vision 20-2020, the projected demand will be about 13 million tonnes by 2020 and increase to 46 million tonnes in 2030.

Table 5: Final Motor fuels demand projection, Mtoe

Scenario	2010	2015	2020	2025	2030
Reference	0.14	4.56	9.99	14.91	22.64
High Growth	0.14	4.77	11.34	20.75	34.33
Optimistic I	0.14	4.93	12.47	24.40	44.04
Optimistic II	0.14	5.21	12.79	26.80	46.17

Table 6 shows similar trend for the final thermal fuel demand, with an initial high demand from 2010 to 2015 followed by a steady increase for the rest periods.

Table 6: Final Thermal fuel demand projection, Mtoe

Scenario	2010	2015	2020	2025	2030
Reference	0.010	0.024	0.056	0.913	0.159
High Growth	0.010	0.029	0.076	0.115	0.276
Optimistic I	0.010	0.034	0.087	0.153	0.345
Optimistic II	0.010	0.040	0.092	0.186	0.394

The total final energy in the construction sector will reach about 24 Mtoe in the Reference Scenario by 2030, whilst in the fast GDP rate of 13% of the Optimistic II Scenario the total final energy demand will be about 50 million tonnes (Table 6). There is an annual increment of 1.2, 1.8, 2.3 & 2.5 Mtoe in the Reference, High Growth, Optimistic I & Optimistic II Scenarios, respectively.

Table 7: Total final energy in construction, Mtoe

Scenarios	2010	2015	2020	2025	2030
Reference	0.158	4.756	10.466	15.63	23.870
High Growth	0.158	5.000	11.910	21.690	36.261
Optimistic I	0.158	5.210	13.099	25.604	46.417
Optimistic II	0.158	5.505	13.475	28.203	48.961

## 4. PRACTICAL STEPS ON THE PATH TO SUSTAINABLE HOUSING

### 4.1 Energy Efficiency and Sustainable Housing

Below are some of the activities of the Energy Commission of Nigeria that have direct impact on sustainable housing for people:

**Voluntary Energy Audit:** In fulfilment of its mandate, the Energy Commission of Nigeria promotes voluntary energy audit and simple Energy Efficiency measures in Residential and Public buildings through nationwide awareness creation programme, studies, energy audit of public buildings and Implementation of ECN/ECOWAS/CUBA 1 Million Compact Fluorescent Lamps Replacement pilot project.

**R and D Centre of Excellence:** in effort to give energy efficiency scientific base and nationwide coverage, in 2007 the Federal Government of Nigeria established the National Centre for Energy Efficiency and Conservation (NCEEC) at University of Lagos under the supervision of the Energy Commission of Nigeria. The Centre is mandated to carry out the following functions:

- Develop guidelines for energy efficient end-user products and advise on their implementation;
- Develop energy efficiency codes, standards and specifications for domestic, commercial and industrial facilities and set up laboratories for the testing and calibration of equipment and appliances to ensure compliance;
- Serve as a centre for training of high-level manpower in energy efficiency and conservation;
- Develop and execute pilot demonstration projects highlighting energy efficiency;
- Disseminate information on energy efficiency and conservation concepts through public awareness programmes such as seminars, workshops and publications.

**ECN Partners UNDP-GEF to Promote Energy Efficiency:** The Energy Commission of Nigeria and the Federal Ministry of Environment Partner UNDP-GEF to Promote Energy Efficiency in Residential and Public Sectors in Nigeria. The project is scheduled to last for four years (2011 – 2015) and it aimed at identifying and overcoming the barriers to implementing energy efficiency measures across the country through improving the efficiency of a number of end-users energy equipment in the residential and public buildings.

It also sets out to focus on strengthening the existing regulatory and institutional framework as regards to energy efficiency, and develop enforcement mechanisms amongst others.

- Under the programme 100 hotel owners, managers, maintenance officers had been trained in energy efficiency opportunities in hotels;
- A team of about 100 electrical engineering professionals were trained (field training) in fundamentals of the energy efficiency as a prelude to successfully carry out the study in the six (6) geo-political zones.
- Training workshop was held for the Manufacturers Association of Nigeria (MAN) in order to enhance the capacity of technicians and machine operators in the industrial sector of the country;
- Also, Study of End Use Appliance Metering in selected households – representing high, medium and low income families – in Abuja and other major cities across the six geopolitical zones of the country is currently ongoing.
  - Monthly and annual baseline data that will be obtained will be used to design the Minimum Energy Performance Standards (MEPS) and Label for mostly cooling appliances so as to be able to monitor the efficiency of these imported energy appliances.

It is expected that introduction of Standards and Labels will enable the Country to reduce national energy demand. Standards and Labels programme for ACs alone may save the Country over ₦124 billion and between 250–500 MW of generating capacity by 2020.

## 4.2 Sustainable Rural Habitat Initiative

The rural community constitutes over 65% of the country's population predominately agrarian. However, the acute energy crisis in the country is decaying the rural social infrastructure, housing and economy, hence, making the rural community livable through provision of affordable and energy efficient housing is very crucial. Two Nigerian institutions – Energy Commission of Nigeria (ECN) and the Nigerian Building and Road Research Institute (NBRRRI) – have developed and adapted energy, housing and road construction technologies using rurally available materials which if integrally applied can transform rural community to sustainable habitat for Nigerians.

The ECN is mandated to research and develop renewable energy technology that can be produced locally to meet the national energy needs, while, the NBRRRI is mandated to conduct integrated applied Research and Development in the building and construction sector. Over the year the two have record significant breakthroughs in their respective fronts and recently initiated process of integrating their technologies to provide sustainable housing for Nigerians.

**Green Energy:** these technologies use inputs that are readily available in the rural and semi urban communities for powering both domestic and cottage industries and they can be conveniently operated and maintained by the rural dwellers.

- Biogas digesters use abundantly available **agro residues** in the rural community for thermal and electric power applications
- Solar thermal Application for production of hot water
- Solar PV stand alone home system and street light
- Solar PV powered boreholes
- SHP

**Green Construction (Building) Materials:** all technologies developed by NBRRRI take cognizant of **Laterites** which occur abundantly in Nigeria.

- Cement-Stabilized Bricks for walling in place of sandcrete blocks
- Interlocking Blocks for walling without using mortar except at first course, gable course and the ring beam
- High Quality Paving Stones for pedestrian and light trafficked road
- Fibre Concrete Roofing Tile (Mador Tiles), Semi Sheet and Clay Roofing Tile Technology

### Expected Outcomes

- Integrated application of these technologies will significantly improve housing problems and better access to energy will positively impact on the rural economy and education, primary health care delivery and other social services.
- The rural-urban migration can be reversed with all aforementioned impacts which consequently will bring additional impacts on the rural community through the presence of skilled and learned inhabitants.
- The cost of building modern houses is reduced by at least 30% and the period of housing delivery is reduced by 30% to 40%.

### Fast-tracking Introduction of the Integrated Initiative

- Putting in place appropriate legislation for promotion of this initiative would be the ideal solution; however, with current low political will to enact energy law another opening must be searched;
- The ECN and NBRRRI can joint work in lobbying both the public and private stakeholders who charged with the responsibilities of providing goods and services at the rural level.
  - The Universal Basic Education Commission (UBEC) can key in by using these technologies in building classrooms for schools;
  - The National Directorate of Employment (NDE) can collaborate in training Nigerians in the technologies and hence, generate employment;

- Ministries of Agriculture can create modern bioenergy Extension workers;
- Millennium Development Goals (MDGs);
- State and Local Governments;
- Federal Ministry of Housing.

## 5. CONCLUSION

The study that produced this article shows that demand of the total final energy demand in the construction sector will increase remarkably up to 2020 and 2030. Motor fuels will contribute the majority of the energy demand with minimal contribution of thermal fuels. The estimated annual growth rates for the final energy demand are 650, 1,042, 1,363 and 1,444% for the Reference, High Growth, Optimistic I and Optimistic II Scenarios, respectively. The ability to provide the forecast energy in a sustainable manner is an important aspect of sustainable construction.

Improvements in the technical efficiencies of equipment used in construction can reduce energy intensity and hence contribute to sustainable construction. Hence attention needs to be paid to energy efficiency and conservation in the sector.

Though fossil fuels use considered as the major source of thermal energy usage in construction, in many instances traditional biomass is utilized as a source of thermal energy to heat asphalt, especially in road maintenance. Traditional biomass would be replaced by modern bioenergy in the future.

Use of grid electricity in construction sites is not common. Most construction firms use diesel generators to provide electricity for their construction sites. Our interaction with them indicates that they would prefer grid electricity if it is available as it should be cheaper. Solar energy may become viable in providing lighting in construction sites in place of captive electricity provided for the sites with diesel generators.

Renewable energies and energy efficient appliances and measures are already making positive impacts on energy demand and cost in both residential and commercial sectors of the economy.

All these should contribute to sustainable building and construction.

## REFERENCES

- Assessment of Energy Options and Strategies for Nigeria: Energy Demand, Supply and Environmental Analysis for Sustainable Energy Development (2000-2030). ECN, 2007. National Energy Masterplan
- Central Bank of Nigeria (CBN) Annual Report 2010, Abuja
- Federal Ministry of Energy (Power Sector), 2008. Investment Opportunities in the Nigeria's Power Sector
- Global Construction Perspectives and Oxford Economics (GCPOE), 2010
- International Atomic Energy Agency (IAEA), Model for Analysis of Energy Demand (MAED-2) User's Manual 2006 Vienna
- International Atomic Energy Agency (IAEA), 2003. Model for Energy Supply Strategy Alternatives and their General Environmental Impacts, *MESSAGE* – User Manual
- National Bureau of Statistic (NBS) Annual Bulletin 2010, Abuja
- Sambo, A. S., 2008. Paper presented at the "National Workshop on the Participation of State Governments in the Power Sector: Matching Supply with Demand", 29 July 2008, Ladi Kwali Hall, Sheraton Hotel and Towers, Abuja.
- Sambo, A. S., 2008. Matching Electricity Supply with Demand in Nigeria. IAEE Fourth Quarter Publication.



**Dr. Vilas Mujumdar,  
U.S.A.**

## **Sustainable and Resilient Infrastructure and Housing – A Need for Enhanced Quality of Life**

American Association of Engineering Societies

E-mail: [v\\_mujumdar41@yahoo.com](mailto:v_mujumdar41@yahoo.com)

### **ABSTRACT**

All communities need properly functioning civil infrastructure, economic systems and societal networks for their daily operations. These systems are parts of the total community system. Sustainability requires rethinking in use of available resources without undue economic burden on future generations. Creating community resiliency is essential for long term sustainability. As the populations grow, existing physical infrastructure and social systems become inadequate, get stressed beyond their capacities and do not keep up with the demands. The stress on the physical civil infrastructure is further aggravated due to aging of the facilities and lack of proper maintenance. The civil infrastructure systems, i.e. transportation systems, utilities, and communication networks are also exposed to hazards, whether natural or man-made. To minimize the impact of these causes on the functionality of a community, it is necessary to build resiliency. A complete community systems approach is necessary. Only then a sustainable community can be established. This paper focuses on specific framework of resiliency at the community level that combines engineering, economic and social issues. Increased resiliency leads to more sustainability.

# 1. GENERAL

Community systems comprise engineered systems such as physical infrastructure along with socio-economic systems. These systems are essential for daily functioning of a community. Their functionality gets impacted when stressed beyond capacity. Stress in the system could occur due to damaging hazard events, whether natural or man-made, aging of the systems, inadequate capacity due to population growth, and lack of proper maintenance. Economic systems of a community could be disrupted due to global economic events as the world economic systems are globally interconnected today. All these causative actions result in disrupting the functionality of a community considerably. As an example, Figure 1 shows the impact of a gas explosion in underground utility line in New York City that disrupted the financial markets causing havoc worldwide.

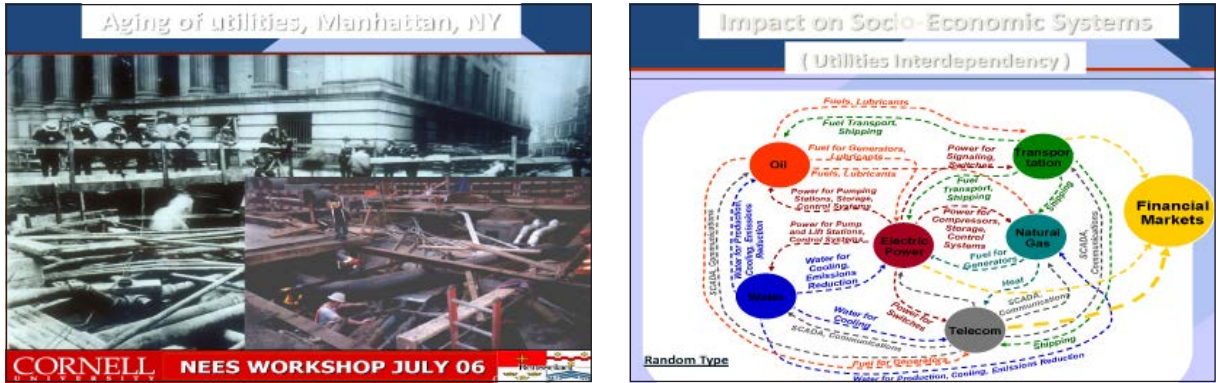

Fig.1 Impact on New York Stock Exchange and Economic disruption – Gas Explosion- NY City

## Aging and Lack of Proper Maintenance of Underground Utility Systems

Civil infrastructure systems go beyond just the physical structures. However, for this paper the discussion is limited to transportation systems, water and waste-water systems, gas pipeline networks, electrical network, and communication systems.

Although each system is designed as a separate engineered system, it has interdependent relationships with other systems, e.g. the transportation network depends on electrical power for its signaling and switching functions, and railroads need electrical power to operate. Similarly, water and waste-water systems need electrical power to operate pumps. If electrical network is damaged these dependent systems are impacted. Each individual system is merely a sub-system within the total community system.



Fig.3 Osaka Port- Kobe EQ '95  
25% of Japanese export through port.  
Disrupted world - wide shipments



Fig.4 Kobe EQ '95- Extensive Damage to Transportation network. (Total Loss- \$150 B)

**Impact of Natural Hazard on Infrastructure Systems and Socio-Economic Systems of a Community & Global Interdependence**

The infrastructure systems, as a group make an overall engineered system for a community. The vulnerability of the overall engineered system depends on the nature and extent of interdependency among various systems. It is necessary to derive joint fragilities to understand the true nature and extent of the engineered system vulnerability. This engineered system in-turn interacts with social and economic systems in ways which are not always understood, and the relationships with them are non-linear.



Fig. 5 Haiti –EQ. -2012 – (2 years after)  
Situation about the same as 2010



Fig. 6 Haiti –EQ. -2010, 316,000 dead, \$8B  
Loss- 100% of GDP

**Inadequate Capacity of Infrastructure Systems –Before and After Earthquake Hazard Event**

The overall impact on the community can only be properly assessed when interaction of the overall engineered system with socio-economic systems is considered. The community complex system and linkages within its sub-systems are conceptually shown in figure 7.

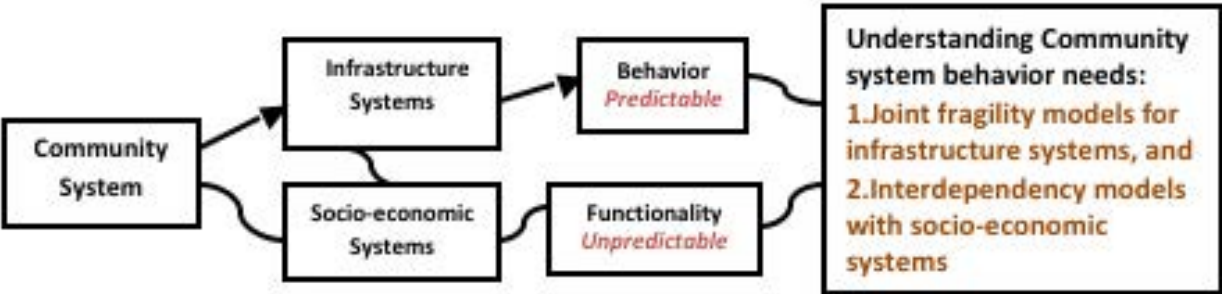

Fig.7 Complex Community System – Sub- systems and Behavior

## 2. SUSTAINABILITY

*Sustainability* as a term is in vogue and is used by different people very loosely in different contexts. Classic dictionary definition of sustainability is: "A state which is maintained at a certain level for a long time (indefinitely)". For development purposes, it is the "development that meets the needs of the present without compromising the ability of future generations to meet their own needs" (*The World Commission on Environment and Development, 1987*). We will use the broadly accepted definition for this paper: "**Sustainable development is one that is environmentally-conscious, economically-viable, and socially-acceptable**" (2005, UN - Brundtland Commission)



Fig.8 Sustainable development- Complex Community- based - Systems Approach

The table, titled "ESI for Selected Countries", shows the Environmental Sustainability Index (ESI) for various countries. The caption below the table states: "(The higher the number, the greater the effort towards sustainability)".

Country	ESI	Country	ESI
Japan	57.3	India	45.2
Italy	50.1	Philippines	42.3
Germany	56.9	Iran	39.8
U.K.	50.2	Russia	56.1
USA	52.9	Nigeria	45.4

Fig.9 Environmental Sustainability Index (ESI) (World Economic Forum, 2005)

Community sustainability comprises of following components:

1. Institutional sustainability
2. Economic and Financial sustainability
3. Ecological sustainability

For the civil infrastructure systems, i.e. transportation systems, water and waste-water utility networks, gas network, electricity generation and distribution systems, and communication networks, sustainability needs to have following considerations:

- minimal the use of additional resources for long term duration,
- choice of materials that are durable for long-term,
- use of recyclable materials,
- use of efficient processes for construction, and
- systems engineered to build operational efficiency on a life-cycle cost assessment basis

## 3. RESILIENCY

*Resiliency* is defined in the dictionary as "the human ability to recover quickly from disruptive change, or misfortune without being overwhelmed or acting in dysfunctional or harmful ways". Resiliency has different dimensions for physical systems and socio-economic systems. Physical systems need to be *redundant* and *robust* while socio-economic systems need to be *robust* and *resourceful*. Community resiliency consists of *built environment resiliency, economic resiliency and social resiliency* (Fig.10).



Resiliency can be generated in two ways: *design of the system*; and the *operation of the system*. Once a system is designed, *resiliency is built-in and cannot be changed*; however, *operational changes may result in increased resiliency*. When infrastructure systems possess little resiliency, systems fail and the results can be devastating.



Fig. 10 Community Resiliency



Fig. 11 Resiliency – Determinants

#### 4. INTERDEPENDENCY AMONG SYSTEMS

As noted before, various infrastructure systems are interdependent. Some examples of interdependency are given here: Water and waste water systems are dependent on electrical network; transportation network is dependent on power; communication network is dependent on power etc. These are *inherent dependencies* when the system is designed, but others actions such as turning off gas lines when electricity lines are broken; and the breaking of water pipes/tubes making the water from faucets not safe to drink are *operational dependencies*. Specific dependency relations need to be assessed and evaluated. An example of water system dependency is shown in figure 12. When the systems are interdependent, it is essential to determine their joint fragilities for a given event that would affect their functionality. *Once the Interdependency relationships are established, systems can be evaluated for enhancing resiliency to reduce the impact of damaging events and increase sustainability.*

The interdependency relationship of engineering systems with socio-economic systems is non-linear and cannot be determined by numerical models. Some of the powerful models that are being developed essentially try to determine the needs and behavior of an agent (client) subjected to a damaging event. Such methods are called *agent-based modeling*. While one may not be able to determine the exact nature of such relationships, it suffice to state that it gives an insight into the behavioral aspects of socio-economic systems and helps us understand the behavior of the overall complex community system. Appropriate decisions then can be made towards design and operations of infrastructure systems to increase resiliency and sustainability.

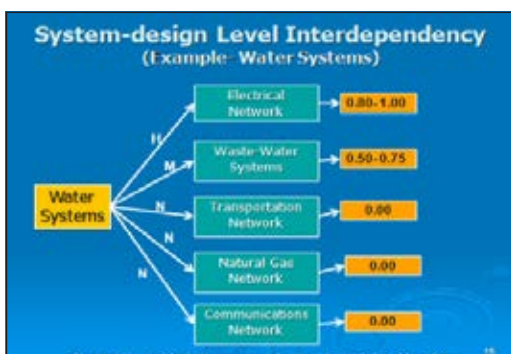

Fig.12 Water System Interdependency Components – Inherent and Operational

## 5. INFRASTRUCTURE SYSTEMS- EXISTING AND FUTURE

It is important to differentiate between infrastructure systems that *exist* and that are going to be *built in future*. The considerations for increasing resiliency and sustainability for each are different. It is also important to differentiate between infrastructure systems in the developed world and in the emerging economies as the causes of stresses have different dimensions and magnitudes.

### a. Existing Infrastructure Systems

In most of the global cities of the world, infrastructure exists to serve the populations. The pressures in emerging economies are that of *increasing population and mass migration* to urban areas for a better economic future. This leads to primarily a condition of **inadequacy in capacity and operations**. Some areas in major cities of Asia do not have basic utilities such as drinking water, waste –water, or power. They may be well connected to public transportation networks and may have communication networks. There is a tremendous challenge in such areas to provide basic services let alone think of sustainability for the future. More than 10 % of the population in Mumbai, India, lack housing, has no power, drinking water or sanitation (*Wall street Journal May, 2012*). Primary problems in existing infrastructure systems to be addressed are: *physical constraints, increasing the size and capacity of existing networks, and financial & economic constraints*.

In the developed world where the pressures of migration to urban areas are minimal, condition assessment of existing infrastructure is necessary as it may be old and aging and is in need of repair. Some underground utility systems are hundreds of years old, with little knowledge of their exact geographical locations and condition of materials used. Electrical generating and distribution systems are particularly vulnerable to damaging events causing serious disruptions in daily function of society and leave psychological scars. Transportation networks may be inadequate due to increase in motor vehicles which also results in environmental pollution. American Society of Civil Engineers (ASCE) grades America's infrastructure every few years. In the latest report (2009) it graded the infrastructure as **"D"** and noted that an investment of \$2.2 Trillion would be needed to fix it. Some examples of infrastructure failure in the US are noted below:

- **The Northeast power blackout of 2003**, during which 50 million people lost power for up to 2 days, at an estimated cost of \$6 billion;
- **The collapse of the I-35W bridge in Minneapolis, Minnesota in 2007**, resulting in 13 deaths, numerous injuries, the disruption of commerce for more than 1 year, and the need for a new bridge at a cost of \$233 million, and
- **The levee failures in New Orleans in 2005**, resulting in approximately 1,500 deaths; between \$20 billion and \$22 billion in property losses; \$4 to \$8 billion in economic losses; \$16 billion to \$20 billion in emergency assistance, and economic, social and environmental effects that were felt more than 3 years later.

(Source: NAE study on Sustainability of Critical Infrastructure- 2009)

**Natural disasters** are particularly damaging to existing infrastructure systems and the society if little resiliency exists. In 2011 alone the total global bill due to natural disasters was \$265 billion. These included floods, tornados, fires and earthquakes. Electricity is the first thing that is lost when certain disaster like tornado, floods, earthquakes, and terrorist's attacks occurs on certain places. Various necessities of life are gone when such disaster happens. Several precious life, livelihood and properties are instantly lost due to these disasters.

Some examples for 2011 alone are:

- **Queensland, Australia rain triggered flooding, loss \$7.3 billion**
- **Catastrophes in the United States caused \$32.6 billion in direct insured losses**
- **Hurricane Irene was the single costliest natural disaster in the U.S. in 2011**. Much of the damage was to infrastructure

- **Severe floods - Bangkok, Thailand, loss \$40 billion.** More than 1,000 factories were shut down and 700,000 people were out of work. Over 800 people died in the floods (UNISDR)

Some unanticipated but disturbing consequences of infrastructure failure could be such as:

- The trial of six Italian scientists and a former government official has begun in Italy after the 2009 L'Aquila earthquake.
- The defendants are accused of manslaughter after giving a falsely reassuring statement before the 6.3 magnitude quake struck, devastating the city and killing 309 people.

(Source- Euro news)

## b. Future Infrastructure Systems

An opportunity exists, specifically for engineers to contribute to the total system approach for designing the infrastructure systems of the future. According to some reports, by 2050, China will have 150 new cities and India will have 100 new cities. These are tremendous opportunities to design infrastructure systems from scratch that are resilient and sustainable for a long time in future. Decision-makers, public policy officials, urban planners, architects and engineers will be designing these cities. Engineers can bring a rich data base, knowledge of systems and their interdependencies. Such knowledge is crucial in making right decisions. It is urged that engineers become full-participating and proactive members of this group right from the start rather than engaged as consultants later.

## 6. CONCLUSIONS

- The overall impact on the community depends on the behavior of the coupled engineered system with the socio-economic system,
- Rethinking the relationship of infrastructure systems with society and quality of life is needed,
- Such rethinking requires a vision based on conservation of resources, life-cycle cost considerations, long-term durability of materials and systems, environmental sustainability, social acceptability and economic viability,
- A system-based approach is necessary that involves various disciplines and stakeholders with multiple objectives,
- A condition assessment of existing infrastructure is required,
- Solutions to upgrade the infrastructure must incorporate the recognition of *the interdependencies* among infrastructure systems,
- Engineers must engage in the public policy process, and provide robust data on economic and financial consequences in upgrading/new infrastructure systems in the overall prioritization of resource use,
- Engineers must demand a seat at the decision-makers table,
- Society expects reliable, resilient, efficient and sustainable infrastructure systems. Engineers can deliver on these expectations in a professional manner with team work approach and other collaborative mechanisms,
- Cities are becoming more sustainable and reducing their risk to disasters through partnerships and collaboration. (UNISDR) However, cultivating a Disaster-Resilient Society for Sustainable Development is important.

## REFERENCES

- American Lifelines Alliance Power Systems, Water, Transportation and Communications Lifeline Interdependencies March 2006 (DRAFT)
- ASCE and American Society of Civil Engineers, 2009 Report Card for America's Infrastructure, ASCE, March 25, 2009

- Department of Homeland Security, National Infrastructure Protection Plan 2006. Department of Homeland Security
- Mujumdar, V, "Multi-hazards, Vulnerability, Mitigation, and Decision-making in Public policy Context", *University of Illinois*, Urbana-Champaign, IL Feb.2009
- Mujumdar, V., "A Need for Risk-Consistent Approach to Multi-Hazard Engineering", *Symposium on Emerging Developments in Multi-Hazard Engineering*, New York, New York, Sept. 18, 2007
- Mujumdar, V., "Quantitative Risk Assessment, Public Policy, and Decision-making", *Proceedings, International Conference on Vulnerability and Risk Analysis and Management (ICVRAM)*, Baltimore, MD, Apr. 2011
- Mujumdar, V., "Interdependency – A necessary Consideration for Risk assessment and Management of Critical Civil Infrastructure Systems", *First Asian-Pacific Symposium on Structural reliability and its Applications*, Singapore, May 23-25, 2012
- Rinaldi, S, Peerenboom, J, and Kelly, T. Identifying, Understanding and Analyzing Critical Infrastructure Interdependencies. *IEEE Control System Magazine*; 21:11-25.

## Mag. Danijel Zupančič, Slovenia



125

DANIJEL ZUPANČIČ

### The Aspect of Sustainable Development in Engineering Practice

Trimo d.d.

E-mail: [danijel.zupancic@trimo.si](mailto:danijel.zupancic@trimo.si)

#### ABSTRACT

When creating solutions for the development of products, systems and technologies engineers are primarily focused on the final objective – i.e. operation, functionality and creation of new added value or even “self-profit”. Often other aspects are often forgotten, but they may have sustainable consequences for the society or the planet. Sometimes these aspects are overlooked under the impact of capital or other known narrow interests, which sooner or later result in an unbalanced situation in the society or the environment. In addition to the provision of new professional and legal solutions it is the responsibility of engineering to influence the decisions in the wide sociological context. It is also a commitment to the concept of the balanced sustainable development. The experience of Trimo shows that this responsibility can reflect in a good result only in the environment that can tolerate open and equal communication that encourages co-operation in interdisciplinary teams, supports innovations, exchange of knowledge and experience at a global level and that develops a business model of balanced interests among all the parties involved. When intertwining information and in the search for mutual common good for people and the planet engineers can count on the critical mass of widely acting persons who are in favour of the most essential changes in the society.

## INTRODUCTION

In today's world, full of changes and unpredictable events and influences, we are often faced with a dilemma when considering the position, role and responsibility of an engineer. Are we as engineers faithful to our profession and ethical rules? Are these ethical rules solid enough, understood in a similar manner all over the world and used in practice? Is it possible to always consider all aspects of engineering to the same degree? Do engineers favour some aspects and neglect others due to the narrow interests of clients or other similarly narrowly-focused reasons? What is the remaining extent of responsible planning with a comprehensive overview of the present and the future of people and the planet as a whole? Is it possible that engineers are adapting to different ways and rules through the prism of capital influence and the power of individuals, lobbies or even countries? Are they still following the course of sustainable development? We are facing an issue that each one of us engineers must find the right answer to. **This means focusing our work on progress that benefits mankind and the planet now and in the future.** It means not abusing progress for the benefit of a single group of people and to the detriment of others or future generations.

This looks like an ethical issue, but it is also a professional issue for engineers since it is often more difficult to find a solution that complies with all the aspects and interests than a more unilateral idea that will satisfy the interest of an individual or a society in the short-term. This issue is also not related to a single moment or a single event, but rather to the implementation of professional tasks of engineers based on strict ethical values and within an engineer's entire professional life and activity. **It is also notable that engineers determine and promote proper ethical values of the engineering profession and practice through associations, chambers and engineering academies.** The engineering profession's communication with the public is clearly expressed through the declared values and ethical standards. This is how engineers set the proper criteria and benchmarks for themselves, encouraging and enriching them in terms of their professional development. On the other hand, this is how they point out limits that are unacceptable for the long-term sustainable development of society and the public may even identify them as irresponsible conduct of engineers or their clients when there are any discrepancies.

Over the last few decades, the decision makers and the engineering sphere have often run into the dilemma of whether the ratio of highly educated people from the social and natural science fields is appropriate. Does training and education still proceed according to the balanced natural way despite the changed attitude to work and way of life? Or is this attitude moving away from the balance that is needed for society to develop properly? Education system reforms that are often too sloppy and not sufficiently thought through, the relatively rigid and late transfer of professional tasks to the successor in educational and research institutions and the high levels of unemployment in individual professions compared to the shortage of certain professions needed for the development of society indicate a lack of balance and an abnormal flow of these events. It is essential for engineers to assume their share of the responsibility in the process of societal development. When such changes occur, it is good to highlight the role models that the engineering profession has in each part of society. Engineers in Slovenia can look up to these role models whose vision and enthusiasm led to the great achievements in science that the whole world is now using to its advantage. This means that we engineers can contribute to the balance and a sort of sustainable development of society through our social responsibility and role models. **Through its social responsibility, the engineering profession must ensure the promotion of professions by virtue of its achievements and by advocating the engineering profession in society.**

Small communities, such as companies integrated into the modern social situation, also face the same dilemmas. Trimo is an international company whose mission statement states that it provides comprehensive solutions in the area of prefabricated buildings, especially building envelopes. In developing its business model, Trimo set out to achieve "a balance of interests among stakeholders", i.e. among owners, buyers, employees, suppliers and the wider community. Achieving some kind of consensus on these stakeholder interests is very important, but what is most important is to keep the "added value cake" big enough and to

make sure that everyone involved in the process contributes their share. The profit category can be understood and interpreted differently from various points of view, but the term added value is easy to understand for everyone involved in the real sector's processes, making the added value indicator one of the key performance indicators. The second most important point in Trimo's business model is for the company to have clearly recorded and communicated values, which every employee can understand and implement in everyday practice. The third important part of the development of Trimo's business model is the employee structure and the balancing of engineering professions in comparison with the social science professions. This is the only way to ensure a large enough potential of development engineers that must follow the strategic objective of achieving a sufficiently high share of income from new products. At the same time, the development of new products, systems and own technologies is systemically managed by taking into account every aspect, including emphasis placed on sustainable development.

Over the course of 50 years, Trimo has progressed through various stages of its own development, the development of society and the industry in which it operates. The small local company of the first 30 years grew into an important supplier of assembly halls for the Yugoslav market. After the breakup of Yugoslavia, Trimo restructured, developed its own business model and went on to become an internationally recognised company. Its solutions and own product and technology development have secured its place in the world as an innovative and flexible company and one of the industry leaders in the sustainable development of products and technologies.

The management's task is to ensure balance among stakeholders, to work out ways to communicate with them and to reach consensus on investments in product and market development as well as the development of new proprietary technologies. The engineers' task is to stay ahead of the competition with new products and to deliver better solutions that will ensure a competitive edge, sales momentum and higher added value. Using such a strategy quickly leads to temptation to have engineers follow only the basic requirements that the market analysts provide as input data. In order to prevent this, Trimo supports and encourages its engineers to meet customers, to be actively involved as sales support at fairs, to meet the competitors and to observe events to see the direction in which the technical field is heading. At the same time, Trimo's engineers are now holding meetings in various associations with experts and developers from institutes that are studying the properties of existing and new building envelope products (roofs and façades). Such products are basically load-bearing components that require special licences for sale to enter the market. For this reason, Trimo's engineers have made contact with the institutes across Europe which are testing individual product properties. They are also participating in common research projects on insulation materials, sandwich panels and energy-efficient building. At Trimo, engineers have a very important advantage – we can try out our products and systems in practice and see their strengths or weaknesses by way of implementing projects for customers. During implementation and even in the validation period, we see what needs to be modified or improved and what is providing added value for the user in a technical sense.

**Through joint participation with clients and fellow engineers in particular, engineers have the opportunity to see firsthand the results of the customers' expectations while the professional circles can identify what is good for the development of products and technologies and for the expansion of new systems in the industry in the long-term.** We meet with engineers from the West and East, from the developed and the developing world, and while there are cultural differences between us, there are no major differences in how we think because we all want to create something new that will be helpful, useful and functional. Although we are competitors on the one hand, on the other we also know that we get satisfaction and motivation for further work by completing certain general tasks together, by being professionally excellent and working for the good of the people using these products and systems.

It does sometimes happen, even among engineers, that a long-term goal is skewed in favour of a short-term goal, local interests, lobbies or prestige. Let me give the example of how the sandwich panel product standard was prepared and its adoption procedure in the European Union in the period from 1990 to 2010.

These panels have been in production in Europe for almost 60 years. This means that at the time the expert task force began its work, the sandwich panel industry already had 40 years of experience. There were also quite a few local regulations and procedures in place that were a good basis for a new common standard. The required product characteristics were mostly already known thanks to the manufacturers and were tested in laboratories and test fields of institutes. Despite the excellent work of the international expert engineer group that drew up the draft standard very systematically, many additional obstructions were created and the draft was rejected. One time it was because of the problematic nature of polyurethane foams (fire, toxicity), another it was because of the harmfulness of mineral wool (the degradability of fibres in a biological solution). The procedures for reviewing the draft standard and verification in national professional bodies took up an enormous amount of extra time. Throughout that time, products were being manufactured and installed in buildings according to local regulations, which required the manufacturers to perform numerous tests on practically the same properties at various institutes in various countries. I joined the task force for the preparation of the standard later on and have recognised the influence of prestige and lobbying as well as the excessively narrow angle of view of development engineers in various countries who were following lobbies instead of their professional commitments. The delay in adopting the standard has caused a great deal of damage to sandwich panel manufacturers which were present in international markets and which had verified the properties (in terms of sustainable development among others) during the development process.

An extremely important part of the strategy throughout Trimo's development over the years includes environmental friendliness in the development of products and own technologies. Actually, the development of the business model and sustainable development were simultaneous, running in harmony and without any preference for any individual aspect. If we understand the business process as a natural and balanced process, then this type of development is perfectly logical. And it is treated as such by Trimo in terms of open dialogue and an atmosphere of good collaboration between various disciplines, i.e. through innovative solutions that generate added value in the long-term. With a passion for new technical achievements, work and the results of designing something together. With a responsibility for achieving results, the satisfaction of process participants and a responsibility to the environment. With mutual trust, which is based on competencies, understanding and respect between employees and partners in the process. And with sustainable development that directs how we engineers work towards superior product quality, achieving excellent technical characteristics of products and a systematic development process. In this process, each stage of product or technology development is studied in terms of its environmental impacts and through the prism of the product's entire life cycle from the basic raw material and up to disassembly.

In the development of products, systems and technologies, Trimo's development engineers follow a strategy of balanced aspects and objectives:

- The quality aspect of products makes it possible for users to use them with the same or very similar properties for as long as possible, which means that making products with a short life cycle is not the goal.
- The diversified product family allows clients to choose among products with standard characteristics and products whose technical characteristics are above-standard compared to the requirements prescribed by technical regulations, e.g. opting for better thermal insulation than presently prescribed by legislation.
- Technological solutions that allow the same or better characteristics using less material – “less is more”. This reduces the need for natural raw materials and energy products.
- Self-developed computer controlled technologies with a high degree of flexibility (high productivity and a very high diversification of products).
- To use the most natural materials which can be recycled and are easy to separate and return to the primary processes of suppliers.
- Together with suppliers, to develop a closed material flow after the end of a product's life cycle – “cradle to cradle”.



- To carry out development in collaboration with the best experts and knowledge centres at home and abroad.
- To actively participate in professional associations and engineering organisations with a view to observe ethical standards and put into practice the values of the engineering profession.

With a long-term sustainable development strategy, Trimo's engineers have developed and achieved the following:

- A product life cycle of up to 50 years (products have been tested in practice for over 40 years).
- Advanced products with above-standard characteristics that even meet upcoming (planned) technical requirements for the next 5 to 10 years.
- Diversified products in more than 100,000 different combinations – an almost complete adjustment to the needs and requirements of customers.
- Over 98% recyclability, closed circuits for secondary raw materials implemented in practice (wool, PE, FE sheet metal, etc.).
- Measured CO<sub>2</sub> footprint throughout the supply chain and product life cycle – a programme to reduce it by 2.5% annually.
- The development of a product that uses CO<sub>2</sub> as a filler in the insulating core.
- Excellent references – Airbus, McLaren, Mercedes, international airports.

Where are the challenges for us engineers today? Sustainable development that is balanced in the long-term now requires responsible engineers to demonstrate even greater responsibility and more collaboration and integration in the profession than ever before. The values or ethical standards of the engineering profession need to be re-evaluated, incorporated into everyday practice and communicated to the wider public. These must also include the value of integrating sustainable development into each engineering solution. We need to achieve a balance of all aspects of engineering work, i.e.:

- promote achievement-oriented engineering that generates added value, benefits mankind and does not cause negative consequences for the current generation and future generations;
- clearly and publicly express our values and the ethics of the engineering profession and live by them in everyday practice;
- care for our successors, which we are obligated to include timely in professional tasks and in responsibility and work together with them to correct the mistakes this generation has made for the benefit of future generations;
- follow the example of engineers from the past, carry out engineering with enthusiasm and courage with the aim of increasing prosperity and reducing differences between people;
- continue to encourage and enrich professional collaboration between engineers to exchange good practices and innovative solutions;
- seek solutions and develop products and technologies with less exploitation of natural resources and energy;
- study professional decisions and impacts a product has on the environment and society throughout its life cycle;
- become more actively involved in the development of society.

In designing solutions for the development of new products, systems and technologies, engineers are primarily focused on the technical objective – operation, functionality and manufacturing. In this, we tend to forget other aspects that could lead to sustainable consequences on society or the planet. Sometimes, this happens under the influence of capital or other narrow interests, which sooner or later causes imbalance in society or the environment. In light of this, besides designing new professionally correct solutions, it is the responsibility of engineers to influence decisions in the wider sociological sense. It is a commitment to the concept of a balanced sustainable development. Trimo's experience shows that this responsibility can only lead to a good result in an environment that is receptive to open and equitable communication, that encourages collaboration in interdisciplinary teams, that opens ways for innovations and a global exchange of knowledge and experience, and which develops a business model of balancing interests between all

stakeholders. We as engineers can create the critical mass needed to bring about the crucially needed changes in society through close collaboration and by seeking the common good for all people and the planet.

# Prof. Dr. Carsten D. Ahrens, Germany



## Offshore Wind Energy and Civil Engineering in Germany – A Green and Sustainable Partnership

World Council of Civil Engineers

E-mail: [carsten.ahrens@jade-hs.de](mailto:carsten.ahrens@jade-hs.de)

### ABSTRACT

The contribution of wind power plants to green and sustainable energy is increasing rapidly worldwide. More and more wind power plants in Germany “go offshore”. Some German construction companies go offshore, too. Their involvement in the offshore energy sector is to do normal civil engineering work like piling down the fundament tubes. But economical and ecological reasons demand a new method, which takes into account rough soil conditions and the unbearable acoustic impact on marine mammals. This new method is a vertical shaft drilling method and will be brought into the offshore energy market by the German companies Hochtief and Herrenknecht.

## INTRODUCTION – EUROPEAN BACKGROUND

In spring 2010, European and international climate experts at PwC, the Potsdam Institute for Climate Impact Research and the International Institute for Applied System Analysis published 100% Renewable Electricity – A roadmap to 2050 for Europe and North Africa. The report examined the potential for powering Europe and North Africa with renewable electricity exclusively by 2050. It set out a series of financial, market, infrastructure and government policy steps that would need to occur if such a 'what if' vision was to be achieved [1].

The European Wind Energy Association (EWEA) published in its latest reports, see also table 1:

Till 29 November 2011 over 141 gigawatts (GW) of offshore wind energy capacity is built, under construction, consented, or planned in Europe: enough to power 130 million average EU households. These wind farms - representing 35 times more capacity than the just under 4 GW installed today - would provide 13.1% of Europe's total electricity production.

EWEA has been analysing all existing offshore wind power projects in 17 EU member states, mostly in north-western Europe. New offshore wind farms with a capacity of 5.6 GW are currently under construction in the UK, Germany and Belgium. It estimates that offshore wind energy offers the growth and jobs that Europe desperately needs. 169,000 jobs in the EU offshore wind energy sector are expected to be created by 2020, going up to 300,000 by 2030, according to the EWEA report.

The wind energy sector's contribution to GDP till 2020 will have increased almost three-fold. If the industry were a Member State, it would rank 19th in 2020 in terms of its contribution to EU GDP, above Slovakia and just below Hungary, and the number of jobs will go up by over 200% to reach 520,000 by then, says the report.

European companies are currently global leaders, with over 99% of the world's installed offshore capacity in European waters. Areas for growth in offshore wind energy include turbine and turbine component manufacturing as well as substructures, vessels, electrical infrastructure including high voltage subsea cables, and ports.

	Online	Under construction	Consented	Planned	Total projects	Size of government concession zones or foreseen future tender zones
Belgium	195	462	750	450	1,857	2,000
Denmark	854	0	418	1,200	2,471	4,600
Finland	26	0	765	3,502	4,294	n/a
Estonia	0	0	1,000	0	1,000	n/a
France	0	0	0	6,000	6,000	6,000
Germany	195	833	8,725	21,493	31,247	8,000
Greece	0	0	0	4,889	4,889	n/a
Ireland	25	0	1,600	2,155	3,780	n/a
Italy	0	0	162	2,538	2,700	n/a
Latvia	0	0	200	0	200	n/a
Malta	0	0	0	95	95	95
Netherlands	247	0	1,792	3,953	5,992	6,000
Norway	2	0	350	11,042	11,394	n/a
Poland	0	0	0	900	900	n/a
Portugal	0	0	0	478	478	n/a
Spain	0	0	0	6,804	6,804	n/a
Sweden	164	0	991	7,124	8,279	n/a
UK	1,586	4,308	588	42,114	48,596	47,000
<b>Total Europe</b>	<b>3,294</b>	<b>5,603</b>	<b>17,341</b>	<b>114,737</b>	<b>140,976</b>	<b>73,696</b>

Table 1: Offshore wind power generators in Europe (online, under construction, consented, planned)

However, the new report warns that if the offshore wind energy sector's potential is to be fulfilled in Europe, it is imperative that sufficient levels of financing are brought in by investors. Also crucial are the financing and building of offshore power grids in the northern and Baltic seas, which would enable huge amounts of electricity to be transported to consumers. For the industry itself, there is a risk of a high-voltage subsea cable shortage in the next few years which has to be addressed urgently, says the report, as well as a possible shortage of trained workers. "The offshore wind energy sector can replicate the success of the onshore wind technology development, which is now a mainstream source of power competitive with new coal and gas plants, and a major European industry", said Zervos. "However, to ensure this happens, EU-decision-makers need to set ambitious renewable energy targets beyond 2020, invest more in research and develop offshore grid".

## FUTURE DEVELOPMENT AND STATUS IN GERMANY

"We are becoming more and more aware of the climate change that we humans have caused. At the same time, we are worried about the security of our energy supply. For this reason, we must make our energy supply viable for the future and place greater emphasis on energy efficiency and renewable energies.

Therefore, with the Renewable Energy Sources Act the Federal Government is pursuing the goal of generating at least 12.5 % of Germany's electricity needs from renewables by 2010, and at least 20 % by 2020.

To achieve this goal, the enormous potential of offshore wind power generation must be tapped. The aim is to construct offshore wind parks with a total capacity of 20,000 - 25,000 megawatt in the North and Baltic Seas by 2030. These can cover around 15 % of Germany's electricity needs.



Fig. 1: Offshore wind power development in Germany [4]

This would give rise to a highly innovative branch of industry, which would create jobs especially in the coastal federal Länder. It would also enable us to reduce Germany's dependence on energy imports and keep electricity prices under control.

I am convinced that offshore wind energy will thus become a major pillar of energy supply in the 21st century”, see figure 1. These words are given by S. Gabriel, former German Environment Minister [4].

The political statement and possible wishes are underpinned by the actual status and the detailed prognosis for the offshore wind power development as described in table 2 respectively figure 2 [2].

Installed	No of WEA	Power [MW]
Total Germany	55	215,3
North Sea	33	164,5
Baltic Sea	22	50,8
under construction	ca. 140	700
Planned		up to 40.000

Table 2: Status in Germany April 2012 [2]

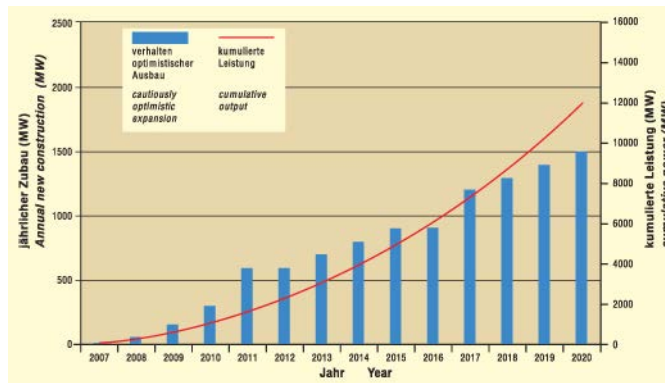

Fig. 2: Forecasted expansion of offshore wind power Generators (WEA) – cautiously optimistic ex-pansion according to Deutsche WindGuard [5]

The priority of offshore wind power generation is clearly described in figure 3, as it compares on- and offshore power generation till the year 2030. Whereas onshore wind power remains stable at a high level, offshore wind energy increases rather rapidly [5].

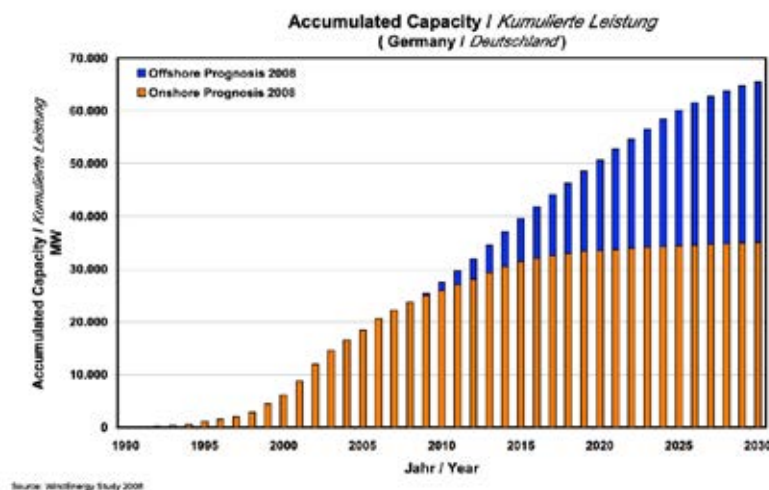

Fig. 3: Accumulated on- and offshore capacity [6]

## CONNECTION TO GRID

In future a significant proportion of Germany's wind energy will come from offshore wind farms in the North Sea, see figure 4, and the Baltic Sea. These farms have to be connected to the land-based power grid. According to the dena Grid Study II [5] different electric connections, including cluster connections, see figure 5, have to be taken into account.



Fig. 4: Wind farm

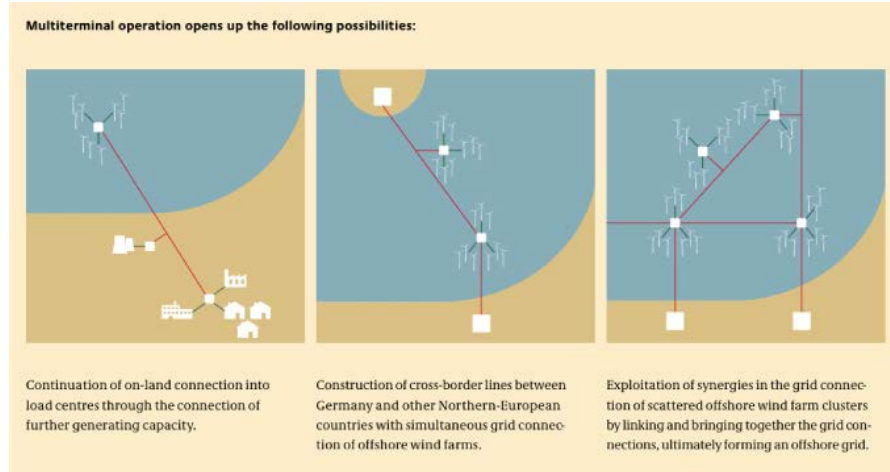

Fig. 5: Connection of wind farms to the land grid

To connect the wind farms to the land grid, by 2020 marine cables extending to a total length of about 1,550 km are needed, resulting in annual costs of 340 million €. The cumulative cost are given in figure 6 [3].

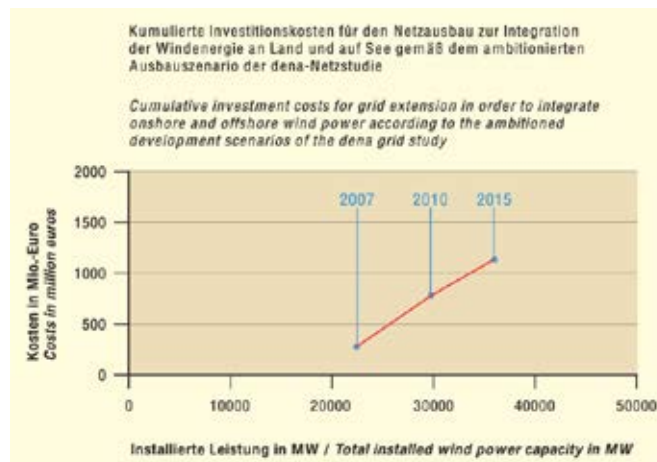

Fig. 6: Cumulative investments for grid extension

The further expansion of wind energy in Germany will reduce relative regional fluctuations and a higher availability of the Germany-wide electricity feed-in from wind energy will be reached.

In accordance to table 1 it is clear that Germany is just one of the many "European wind farmers". Therefore it is reasonable to connect these wind farms with a so called supergrid in Europe and, thus, opens the electricity market within Europe.

The "friends of the supergrid" [7] are much emphasising such a grid to balance regional shortages and/or overproduction of electric energy. This project includes all kind of renewable energy and could include in a later phase also North Africa.

Figure 1: Supergrid Phase 1



Fig. 7: The European supergrid Phase 1

### INVOLVEMENT OF HOCHTIEF AS A CIVIL ENGINEERING COMPANY

Under the motto “Civil Engineering and Marine Works” the internationally active building company Hochtief is very much engaged in offshore wind power plants. By this Hochtief offers normal civil engineering know-how and work in soil investigation, piling of tubes as tower fundamentals, marine logistics, but also comes up as a ship owner. This is “competence far from the coast”, as one of the advertising papers is describing this new business segment [10].

Figure 8 is showing that the spectrum of engagement covers all topics as described earlier. Even laying sea cables is a new work of this – old and settled - civil engineering company [10].

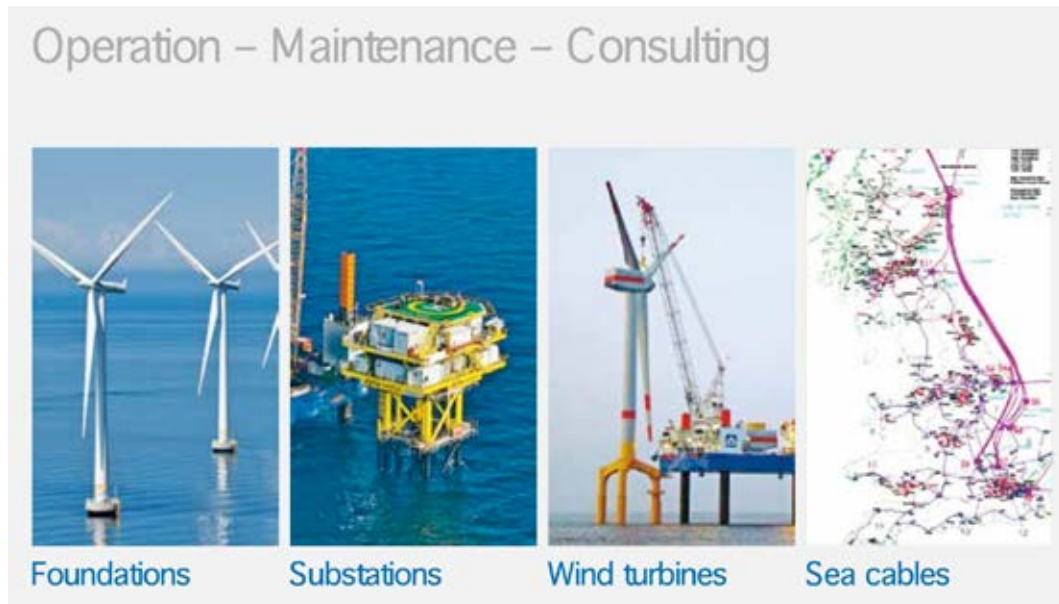

Fig. 8: Involvement of Hochtief as a civil engineering company at high seas [10]

The offshore market is booming. In mid-2012 the first jack-up vessel will be launched for implementing large-scale wind farms: far away from the coasts, in deep waters and operating big turbines. From 2012 more than 800 wind power plants will be installed each year in Europe, and 80% of these will be set up more than 50 kilometres from the coast. The majority of the projects are to built in water depths from 35 to 50 meters. Because the power of the turbines becomes bigger and bigger (more than 6.5 MW) the foundation structures of the wind generator towers have to be adequately strong.



With the offshore jack-up platform Odin, HOCHTIEF has had its own specialized equipment available since 2004. In 2010, the jack-up vessel Thor was added. From the beginning, HOCHTIEF Solutions has assembled its own offshore crew, from deckhands to captains. Since 2010, HOCHTIEF Offshore Crewing GmbH has been responsible for recruiting. In partnership with IG BAU, the pioneering company has introduced its own in-house collective agreement for its crew. “Our crew has many years of experience and expertise in services for wind power plants at sea and offers a sound level of education and training. In addition to professional qualifications, it is qualified to carry out any crew change by helicopter or to provide medical care or fire fighting services”.

Out on the open sea near Borkum Hochtief was involved in the installation of the first German offshore wind farm Alpha Ventus. It completed the soil investigation and built the transformer station and half of the twelve foundations with its own jack-up platform ODIN, see figure 9.

In Öresund, seven kilometres off the Swedish coast near Malmö, Hochtief manufactured and transported 48 heavy weight foundations, see figure 10.

In the Bard Offshore 1 field Hochtief piled down the so called tri-piles with its own heavy lift platform Thor, see figure 11.



Fig. 9: Farm Alpha Ventus

Fig. 10: Lillgrund close to Malmö

Fig. 11: Thor at Bard Offshore 1

Hochtief Offshore Solutions offers a tailor-made maintenance strategy for wind power plants. This combines logistic, constructional and service measures in an early project phase, includes also regular inspection and repair routines, for example for foundation structures, substations and sea cables.

## OFFSHORE FOUNDATION DRILLING (FOD) BY HERRENKNECHT

Up to now Herrenknecht was one – or is now - of the world leaders in horizontal drilling techniques. All over the world big tunnel projects for railways, underground trains, express highways, water flow etc. have been built by Herrenknecht. The last development in drilling started with the so called vertical shaft machine technique by which numerous shafts for underground stations, parking towers, water distribution and inspection [11].

“In partnership with Herrenknecht AG, HOCHTIEF Solutions has developed a more efficient and, most of all, more environmentally friendly way of emplacing wind turbine foundations.” So far the citation of Hochtief.



By this technique, called **offshore foundation drilling**, foundation structures for wind turbines are anchored to the sea floor by a drilling process. This method is highly adaptable, thus, offshore foundation drilling opens up various other technical options, such as drilling pile diameters bigger than the six meters that mark the limit for conventional pile driving.

Herrenknecht started a feasibility study from 2007 – 09 together with the Technical University Hamburg-Harburg TUHH) and the Institute for Applied Physics (ITAP), Oldenburg [12]. The study concerned the technical stability of the foundation, its economical feasibility - and the noise reduction.

The next step forward took place with Hochtief to develop the complete concept, especially with respect to the detailed drilling procedure and necessary ship support. In 2012 an electricity company (EnBW) joined the consortium. A prototype of the offshore drilling machine has been installed, tests have been made for certification. Additional scientific guidance and monitoring has been agreed upon.

This new drilling device offers the possibility to bring down huge foundations, where the normal piling method fails. And it can successfully work also in gravel and clay sea beds.

But the most ecological and future oriented advantage of this technique is its noise reduction of the foundation process to a very low sound pressure level.

The resulting underwater noise pressure of normal piling processes can seriously harm marine fauna, especially harbour porpoises – not only in the German North Sea and Baltic Sea.



Fig. 12: Sea bed and animals

The advantages of the offshore foundation drilling method are obvious. Huge foundation from 4 to 7 m in diameter - and possibly more - can be brought to the sea bed as they are used for monopole wind power towers. The new system on the other hand and with another drilling device can drill also smaller tube foundations e.g. for tri-piles or tri-pods, which have diameters of 2 - 3 m, as figures 13 and 14 show.



Fig. 13: Large Scale drilling Technique (OFD-LD) for monopole foundation

Fig. 14: Small Scale Drilling Device (OFD-SD) for dissolved structures

## ECOLOGICAL IMPACT AND SOUND REDUCTION

The greatest problem connected with the foundation of wind power towers is the great noise impact onto the sea mammals, especially porpoises. The sound pressure reaches values of up to 190 dB in a distance of 750 m from the piling process. Due to German law as published by the German Federal Water Authority (BSH) only 160 dB are allowed in that distance. So, each of the German wind power generators have been built "out of law".

As this is a specific German issue, there are currently no effective measures for the reduction of impact noise that might be integrated into complex installation logistics. In other European countries, where large numbers of offshore wind farms have already been built, the relevant licensing authorities simply require applicants to ensure that sea mammals are kept temporarily at a distance. Using sonar buoys – so-called pingers – acoustic signals are emitted before the installation of the foundation, ensuring that sea mammals are kept at bay. Whale watchers then monitor the area around the construction project and provide feedback on the effectiveness of the pingers. Moreover, during the piling process, a "soft start" ensures that fish and porpoises are kept at a distance from the project area.

Huge efforts have to be done to reduce the noise. At the very first installation Fino 3 a cylindrical curtain of air bubbles has been installed – with relative poor results, see figure 15. Another trial to reduce the piling noise is shown in figure 16. A huge (hand sewn) cylindrical bubble curtain is pulled around the piling hammer and foundation [13]. The proud information as given on the advertising paper talks about 50% noise reduction. This sounds quite a lot, only half of the noise. But as the sound is measured in a logarithmic scale one half is only a reduction of just 3 dB. So, from e.g. 180 dB the value goes slightly down to 177 dB, which seems to be really nothing.



Fig. 15: Air bubbles around platform Fino 3



Fig. 16: Air bubble curtain around pile [13]

A research programme for the evaluation of systems for the reduction of piling noise (ESRA) [3] is planned to be launched in cooperation with eight builders of German offshore wind farms. The purpose is to protect porpoises during the building phase and thus to ensure the unhindered construction of offshore wind farms. On 17th May 2011, eight builders and operators of German offshore wind farms have concluded this joint venture agreement under the umbrella of the German Offshore Wind Foundation. The aim is to research and develop the efficiency of various noise reduction methods in the construction of offshore wind farms.

One special feature of this project is the inclusion of the greatest possible number of German offshore planners and operators to make the benefits accessible to the entire German offshore industry. Having analysed the readings, the joint venture partners will provide all project partners with the final report, which will include their recommendations for each of the technologies. This will also benefit licensing authorities and manufacturers of noise protection systems. Numerous workshops will be held, explaining the results and discussing the further procedure.

Herrenknecht in co-operation with Hochtief will have the “best cards” with its new offshore foundation drilling technique. Figure 17 shows the different sound measures according to the different methods or law respectively. The data are taken or calculated for a distance of 750 m. The thick red bar describes the continuous sound level during piling, the value is between 165 and 175 dB. The blue line represents the value of 160 dB as fixed by BSH. Far below, namely more than 40 dB, lies the value of noise as generated by the new offshore foundation drilling method of Herrenknecht. – The description is in German language: Schalldruckpegel – sound level, Dauerschall – continuous sound, Grenzwert – limit of measures, Bohren – drilling, Rammen – piling, Schalldruck [Pa] (logarithmisch – sound pressure [Pa] (logarithmic), Unterschreitung – sound pressure difference below blue level.

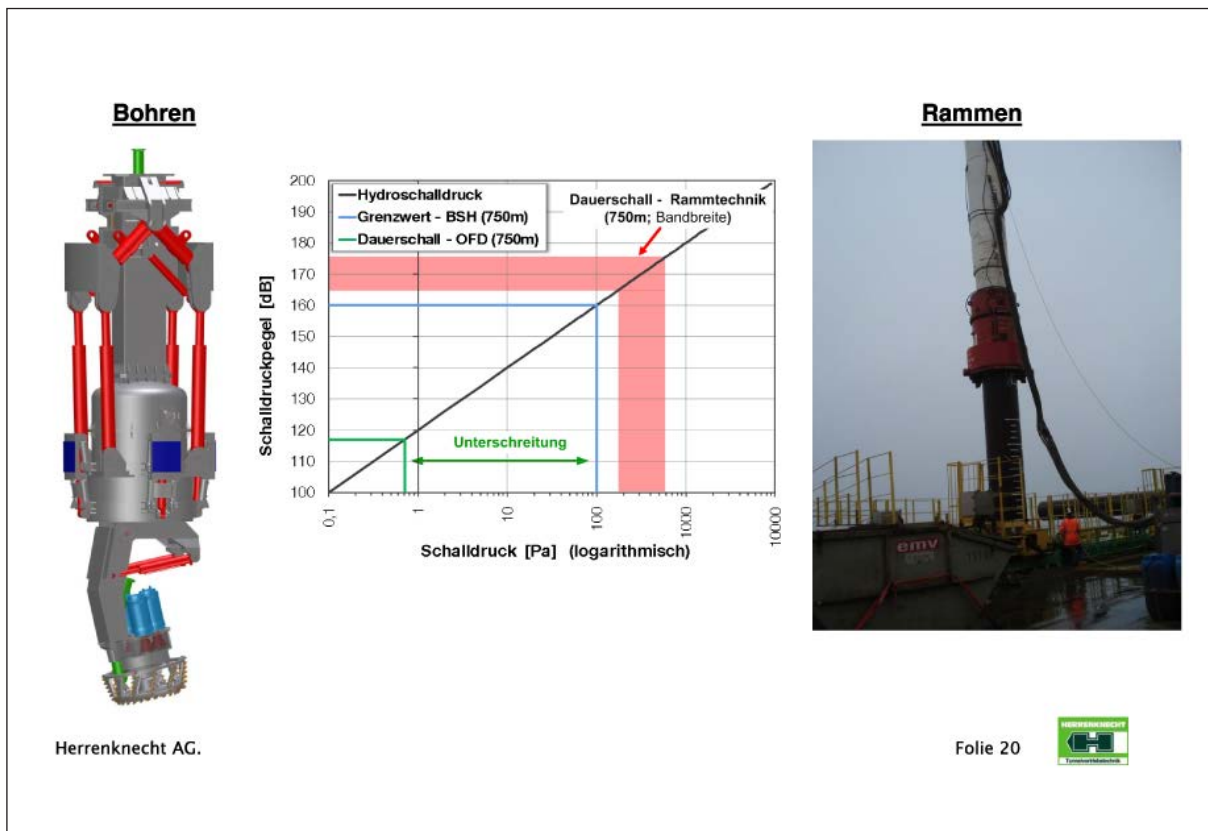

Fig. 17: Sound level measures OFD (green) – BSH-value (blue) – piling (red)

## SUMMARY

Offshore wind power is one of the strong green energies of the future in Germany. Foundation works for the wind power generators, marine logistics service, laying down sea cables and building onshore cable networks are new, very interesting and future oriented work fields of the German companies Hochtief and Herrenknecht as members of the civil engineering world.

## BIBLIOGRAPHY

- [1] [www.pik-potsdam.de](http://www.pik-potsdam.de) (Arthouros Zervos, President of EWEA, 2011)
- [2] [www.ewea.org](http://www.ewea.org)
- [3] [www.offshore-stiftung.de](http://www.offshore-stiftung.de)
- [4] [www.offshore-windenergie.net](http://www.offshore-windenergie.net) (Sigmar Gabriel, former Federal Environment Minister of Germany)
- [5] [www.dena.de](http://www.dena.de)
- [6] [www.husumwindeneergy.com](http://www.husumwindeneergy.com)
- [7] [www.friendsofthesupergrid.eu](http://www.friendsofthesupergrid.eu)
- [8] [www.dewi.de](http://www.dewi.de)
- [9] [www.wind-energie.de](http://www.wind-energie.de) (bwe)
- [10] [www.hochtief.de](http://www.hochtief.de), [www.hochtief-solutions.com](http://www.hochtief-solutions.com)
- [11] [www.herrenknecht.de](http://www.herrenknecht.de)



- [12] [www.itap.de](http://www.itap.de)
- [13] [www.menck.com](http://www.menck.com)

Figures 8, 9, 10, 11 have the copy right of Hochtief, figures 12, 13, 14, 17 that of Herrenknecht.

# Pradeep Chaturvedi, India



## Renewable Energy Systems

WFEO Energy Committee

E-mail: [pradeepc08@gmail.com](mailto:pradeepc08@gmail.com)

### ABSTRACT

Energy security has become a serious issue in view of limited access to fossil energy sources. Construction sector is growing at a fast pace, and most of that is happening only in the developed world. Innovative technologies and practices have evolved that make maximum use of renewable energy sources. The war in Afghanistan and Iraq has forced the United State to provide larger fund support for speedy promotion of renewable energy systems so that distributed and large habitations can be self-sufficient. At the same time the developing countries have also searched solutions that can make electricity availability a reality in remote areas. This compulsion has made all countries to identify sources of energy and technology most suitable to them.

Recent actions have made larger applications practically in the domain of the sustainable technologies. Various studies under WFEO have shown that enough sustainable energy technology options are available that can be promoted through appropriate policy decisions and financial support mechanism that will not necessarily be based on market mechanism only.

The Paper will focus on global efforts and the global possibilities of renewable energy systems in creation global infrastructures now and by the year 2030, resulting in their increasing contribution.

## INTRODUCTION

The World Energy Council and the World Federation of Engineering Organisations, along with the International Energy Agency have projected that by 2035 the world energy consumption is going to rise more than 50%. We are going to be just as reliant on fossil fuels as we are now. And our carbon emissions problem is going to get worse – much worse. But the International Energy Outlook has pointed out that it does not take into account any policy changes that may affect the energy mix across the world. The renewable industry knows better than anyone else that policy is king, and that the success of a growing industry is tied directly to that government support.

The world currently revolves around crisis of fossil fuel, especially oil. Recently the coal prices have also started making their impact on the global energy scene. There are other factors at play that could make renewable energy a bigger player in the decades ahead.

## SUPPORT OF UNITED NATIONS

UN Secretary General, Ban Ki-moon has said that renewable energy will lead developing nations out of energy poverty. The UN programme on Sustainable Energy launched in January 2012 is a step in that direction. It tends to reason that in places like Sub Saharan Africa and India, renewable energy will find a growing market. Some experts may feel that his statements are in stark contrast to the reports, which find that developing nations will drive the energy consumption, but not necessarily with renewable sources. There are, however, some hopeful signs led by large corporations and small communities. In areas often powered by fuels like kerosene, there is little existing infrastructure with which to compete. Some large scale projects, such as what we have seen in Kenya, India and China may prove that massive wind farms are the best way to power growing economies. One look at solar insolation map shows how vast and untapped large scale solar is as a global energy source. Or will the solution include more small scale and localised approaches, such as what is being done in Bangladesh? Developing nations are fairly new as investment areas, so successful projects early on have to go a long way toward turning economies towards renewable and away from fossil fuels.

## GRID PARITY WILL DECIDE FUTURE OF RENEWABLE POWER

The biggest challenge for solar energy application is the comparison of grid parity for electricity supply with conventional sources of energy. The basic issue considered by experts is whether the grid parity will be attained by year 2035 or early. Feedback from different areas indicate that in certain localised conditions the grid parity have already been achieved and in larger such areas the grid parity will be attained within the next five years. It is not the technology or the funding that will be crucial for larger use of renewable energy based system but it will basically be the pricing that will truly be the transformative force that will redefine the world's energy mix. Once we are at true grid parity, it will become a matter of retiring existing fossil fuel plants. Two glowing examples by the end of 2011 have shown that major players are making huge strides toward grid parity. First Solar, announced that it is developing a thin film cell with a 15% efficiency in mass production. GE, in the meanwhile was working to create a 10-15 MW wind turbine. Advancements like these will combine the inevitable gains that come with greater scale to make grid parity a reality sooner than later. The Chinese solar PV manufacturers have already shown their determination in the manufacturing sector and have virtually driven out all major players of photovoltaic out of the solar PV market. There are controversies and the US has placed an extra import duty on the basis that the Chinese government is supporting through extra subsidies which virtually results in dumping of Chinese photovoltaic cells into the international market. No doubt the Chinese are fighting it out into the WTO regime, because no such countervailing customs duties can be imposed on international trade. We have still to wait and watch the outcome of that tussle, but it is quite representative of the fact that determined



efforts of the industry has shown the way that the prices of the renewable energy products can be brought down and make the renewable energy based system attain grid parity at a much earlier date than it was predicted.

India's solar mission programme which an emphasis on putting 20,000 MW of solar power by the year 2022 is another example where the grid parity in the country is expected to be achieved in next two to three years.

The success of the renewable energy system will also depend on how its competing sources grow or vanish. In the US, environmental concerns are likely to force the closer of some of the most inefficient coal plants. Solar and wind are likely to compete or partner with natural gas as the replacement source once the older coal plants go offline. Across the rest of the world, coal use is expected to remain relatively flat. But in Asia, it is expected to continue its meteoric rise. Will the trend last? Residents across Asia – and especially China – are becoming more vocal about the effects of industry on the environment. In a consumer poll released in June 2011, about 53% of respondents in China listed climate change as the world's greatest challenge. There is no doubt that coal will remain the main source for China and India as the power generation medium. Citizen in both the countries are becoming environmentally conscious and are demanding cleaner use of coal and introduction of clean technologies in cradle-to-grave principle so as to make it essential that coal mining, coal combustion and the residue disposal are all environment friendly.

Nuclear had gained its significance and had also positioned as a stable and sustainable energy supply option. However, the Fukushima nuclear crisis may go down as the single natural event that has had the greatest impact on our energy future. The political fall out from the Tsunami stricken plants have moved two of the industries biggest supporters – Germany and Japan – to-re-evaluate their energy policies without the use of nuclear power. As a result both nations have positioned themselves as leaders in renewable integration into their current mix. The anti-nuclear shock waves were felt in the business world, when Siemens cited Germany's move as the reason for the company pulling out of the nuclear industry all together.

The new wave of marketing is affecting the consumer interest. Despite the inroads made in recent years, a surprising number of consumers have given little thought to how energy is generated. May be that will be one of unintended consequences. The bottom line is that more and more consumers consider where their power comes from, and more they may then tailor their buying habits accordingly. That is the hope for the wind industry, which recently launched a WindMade Label, that is telling consumers what percentage of energy was used for certain projects on store shelves in US. The thinking is that once you go straight to consumers, they will drive the market through their purchasing decisions. The same could happen at the pump, if drivers are presented with real, competitively prices renewable fuel options.

Reality or the construction sector has a large possibility of utilising renewable energy systems without adding to the cost to the exchequer. Often the debate is about the costing of adding solar energy to existing systems. But what if the energy system was integrated into the design from the beginning? What if you did not need to calculate how much it would cost to add solar panels to your roof because all roofs are already incorporated solar and this was a mandate for all new constructions? Often times, integration means that the costs of the solar embedded into the roof or the walls is offset by savings in construction material. Renewable energy systems built into a policy structure would make new construction more energy efficient and more cost effective in long-term. Some countries have already made solar for hot water system and solar lighting system as a compulsory part of their work.

## THREE SIGNIFICANT EXAMPLES OF RENEWABLE ENERGY INNOVATION AIMED AT INVESTMENT

The renewable energy entrepreneurs are losing no opportunity to achieve breakthroughs on the basis of innovation that will attract investments.

### Cost-Effective Concentrating Solar Power (CSP)

Concentrating Solar Power (CSP) has struggled to keep up with the rapidly falling prices of PV, making the technology a hard sell to investors.

3M's Renewable Energy Division and Gossamer Space Frames have teamed up to design a parabolic trough technology that they say sets a world benchmark for solar concentration and could ultimately reduce the installed cost by 25 percent. The companies say they achieve the new highs in capacity and new lows in costs by combining 3M's Solar Mirror Film 1100 with the designs of Gossamer Space Frames. The demonstration facility is fully operational in Daggett, California, at the Sunray energy facility, which is owned and operated by Cogentrix Energy.

The new system, which had its ribbon-cutting ceremony in early April, began operating in October 2011 and provides a peak of approximately 275 kw of electricity. A second project using the system design is underway in a separate location and project commissioning is scheduled for June.

The National Renewable Energy Laboratory (NREL) has verified performance of the system, measuring an optical accuracy of more than 99 per cent.

### Abandoned Mines and Geothermal Energy

Abandoned mines are costly to monitor and maintain, and a potential danger to surrounding communities. They are also an untapped source of geothermal energy.

Researchers at McGill University in Canada have investigated a method to determine energy potential when flooding mines with water. This technique has already been used at certain sites in Europe and Canada, but McGill researchers hope to expedite adoption with a model that engineers can use to predict a mine's geothermal potential.

The process seems to be straightforward: flood a mine with water, allow the water temperature to rise from naturally hot rock, pump the water to the surface, extract the heat to create steam and ultimately energy, and pump the cool water back into the mine.

According to the researchers, each square kilometre of mine could produce about 150 kW of capacity. Up to one million Canadians could benefit from this method, and the potential rises in more densely populated nations.

### Atlantic Wind

*N mid May* the Department of the Interior, USA gave the Atlantic Wind Project permission to move ahead with an environmental impact statement for an underwater transmission line that would span 350 miles from Virginia to New Jersey.

Once transmission cable is dropped along the ocean floor, the project would serve as a backbone for an offshore wind industry that so far has struggled to get in the waters off the Atlantic coast.

The project \$5.5 billion has some serious high profile backing with Google and Elia, a Belgian-based transmission system operator. It would enable integration of up to 7 GW of offshore wind, and it'd serve some of the major metropolitan areas of the East Coast.

The Atlantic Wind project is among the many major global transmission projects that have been proposed in the first half of 2012. And many of these projects have a stated goal of linking renewable sources to far away population centres. Iceland has proposed a transmission line along the ocean floor nearly 1,000 miles long that would bring geothermal energy to the U.K., China started building out its transmission superhighway that will bring solar and wind to growing population centers, and India and Pakistan are among the nations in South Asian Association for Regional Cooperation that are in talks to build out regional transmission lines that would allow power sharing between nations.

## **WBCSD: ENERGY NEEDS OF 9 BILLION PEOPLE CAN BE MET SUSTAINABLY**

A new publication released on 23<sup>rd</sup> May 2012 by the World Business Council for Sustainable Development (WBCSD) outlines how the 30 per cent increase in global energy demand forecasted for 2050 can be met sustainably. The Energy Mix: Low-Carbon Pathways to 2050 explores the challenges and dilemmas of meeting this demand at the same time as halving 2005 GHG emissions levels.

The report identifies challenges that imply a radical departure from historical energy pathways. They require government policy intervention and public support at a level not seen in the past, in order to unleash the market forces needed to deploy massively low-carbon solutions. Three overarching issues need to be addressed in order to set a course towards establishing a sustainable energy mix:

The first is the significant risk of lock-in to the GHG emissions trajectory, due to high capital costs and the longevity of energy assets. This creates a barrier to change and, unless it is addressed now, will reduce the possibility of halving emissions by 2050.

A clear, unambiguous and well structured energy policy framework is required in all countries. It has to be effective across different economies and sectors in order to shift the energy mix and deliver emission reductions faster than dictated by historical energy trends.

Finally the role of carbon pricing is critical. A carbon price is one of the most powerful mechanisms available to reduce greenhouse gas emissions within an energy policy framework. Research shows that in the absence of technology breakthroughs in the longer term, a global carbon price needs to be in the range of US\$ 100-200 per ton of CO<sub>2</sub> to have a substantial impact.

## **POLICY THRUST: KEY TO RENEWABLE ENERGY REVOLUTION**

The global performance of renewable energy despite strong headwinds has been a positive achievement in turbulent times. Today, more people than ever before derive energy from renewables as capacity continues to go, crisis continue to fall, and share of global energy from renewable energy continues to increase.

Renewable energy policies continue to be the main driver behind renewable energy growth. By early 2011 at least 119 countries had some type of policy targets or renewable support policy at the national level, more than doubling from 55 countries in early 2005. More than half of these countries are in the developing world. At least 95 countries now have some type of policy to support renewable power generation. Of all the policies employed by governments, feed-in tariffs remain the most common.

Beyond Asia, significant advances are also seen in many Latin American countries, and at least 20 countries in the Middle East, North America and Sub Saharan Africa have active renewable energy markets.

Renewable energy even in the most remote areas is ensuring that the world's people are gaining access to basic energy services, including lighting and communications, cooking, heating and cooling and water pumping, while also generating economic growth through services such as motive power.

The policies in China and Germany and the subsequent investment flow promoted mushrooming of renewable industry. This also led to the proliferation of me-to companies. discussions of consolidation and decreased growth prospects became common. The industry learnt through experience that consolidation becomes primary path to sustained growth and profitability in segments, such as solar energy, wind power and bio-fuel. China, which is now one of the leading manufacturers of renewable energy equipment, reflects that the foreign investors require to look harder for quality opportunities to serving an increasingly domestic markets.

The recent stage presents significant potential return for foreign investors that invest time in developing a deep understanding of the domestic markets, and in building relations with experiences local partners to uncover unique, harder to find opportunities.

## WFEO AND SUSTAINABLE ENERGY

The Energy Committee of the WFEO closely followed the recommendations of the Commission on Sustainable Development of the United Nations. CSD-9 in May 2001 observed that foremost in the developing countries' is the eradication of poverty for the furtherance of sustainable development. Efforts need to be made to ensure that energy policies are supported to those priority, with financial assistance as appropriate. Subsequently CSD-14 in 2006 and CSD-15 in 2007 focused on the thematic cluster of energy for sustainable development. WFEO was continuously involved to review five years of the action on energy issues that affected energy flows on the global level.

Realising the need to study deeper a Study Group on "Status of Sustainable Energy Engineers" was set in late 2008 under my Chairmanship. Its report was released in September 2009 and for the first time highlighted the role of engineering in ensuring sustainable energy supply.

WFEO's lead in this direction was widely appreciated.

## CONCLUSION

Renewable energy systems are getting centre stage in energy supply in the globe for reasons of technological developments and competitive pricing of the products. It is really contributing to greening of the environment and the processes. The sustainable development revolution is moving in the direction of green technologies, green energy, cleaner technologies in various production processes and also in infrastructure, housing and transportation. Advancements in renewable energy systems has given renewed hope to follow the path of sustainable development and still keep global warming within 2 degree centigrade – as it will reduce GHG emissions and in effect promote growth and wealth creation in poorer countries.

# Prof. Mauricio Porraz, Mexico



## Ocean and Coastal Engineering

Academia de Ingenieria

E-mail: [mauricio@porraz.com](mailto:mauricio@porraz.com)

### ABSTRACT

In view of the ever growing need for renewable and clean energy sources in face of a global energy challenge an intensive study was carried out to determine the feasibility for using sea tidal resources in Mexico for a power plant, which led to a group of Mexican engineers to find a different alternative using new technologies.

The site chosen was the Gulf of Santa Clara where tides are of great magnitudes. Two principle elements were considered: constructing a barrier using non-conventional technology and a double basin scheme. The barrier would be constructed using a recently developed material called Seacrete®, consisting of marine concrete formed through a bio-electrochemical accretion process, anchored on concrete columns.

## INTRODUCTION

Distinguished ladies and gentlemen attending this very important and crucial forum regarding the sustainable construction for people it is a great pleasure and honor to be here and to be able to present some thoughts and ideas regarding this matter.

As we are all very aware nowadays the problems arising from the threats to mankind due to climate change has passed from being a slight matter to a really dangerous situation.

It is now a fact, which cannot be disputed that this problem has arisen from the greenhouse effect due to the everyday bigger emissions of gasses produced by factories and transportation modes.

This effect has given way to a series of phenomena which were unforeseen several decades ago but have become an undisputed problem today, such as in increase in global temperature, severe weather patterns causing droughts in some parts of the world and flooding in others, bigger and more stronger hurricanes, melting of the ice in the polar caps which are causing the sea levels to rise.

These last two are presenting a severe threat, especially to the coastal zones worldwide, where every day we find more human settlements, more touristic developments, more costal infrastructure such as roads, factories, fisheries, etc., etc.

We cannot keep on depending forever on fossil fuel for everything, this has to be reduced wherever possible developing and strengthening technologies not dependent on this sources, such as energy obtained from wind, tides and waves, which are natural, renewable and sustainable and present everywhere on the coastal zones with varying magnitudes.

They are a free source of energy, although the mechanisms and technologies are not and must be subject to research and development in order to be able to attain economic solutions.

One of these issues is producing electric energy, which is in greater demand from day to day, and in this case I will specifically refer to the effort that should at the same time increase for producing electricity harnessing the great and always present and available energy in tides.

As we all know the sea is in a perpetual state of motion, and apart from the waves, the tides, which depend on the gravitation influence of the sun and the moon and of the bathymetry and configuration of the sea floors vary from site to site, but are always there, although with different magnitudes depending on these factors.

Nowadays there have been constructed some tidal electrical energy producing plants in several parts of the world with different types of arrangements, equipment and capacities and which should serve as an example that it can be done in other parts of the planet if governments and private sectors work together to make it become a reality.

In this forum I am presenting a paper named "Renewable Energy With Sea Tides" where a very plausible solution is being taken into account making use of the great tidal variations found in the Sea of Cortes, also called the Gulf of California in the northwestern part of Mexico.

For those interested I point out that details of this project can be seen in the paper. But here it is to be mentioned that the concepts considered are very innovative from the construction point of view, starting from the strategic location of the plant, the manner in which a series of columns will be constructed and placed and an extremely new concept of using the minerals found in the sea water to fabricate the enclosure walls.

All of this leads us to take into consideration that the fact is that new and sustainable solutions can and must be researched by the scientific community in profiting from the energy the tides offer us for producing clean energy which will avoid keeping on contaminating the atmosphere and the seas.

To this last matter the global changing climate, which is, as has been said before, warming our environment and which besides the rising of the sea levels is limiting the capacity of the sea water to keep on absorbing more carbon dioxide and which at the same time is increasing the acidity of the waters, damaging the corals, sea life and affecting the fisheries worldwide.

It is time to reduce the consumption of oil and gas, which besides being a contaminating factor is not a renewable source of energy. It is time to focus more on available and existing alternative and sustainable sources of energy. It is time to strengthen research and development to harness the natural energy we have all around us.

And lastly I wish to thank the organizing committee of this forum of Sustainable Construction for People for giving me the opportunity to present my point of view to all the attendees.  
Thank you ladies and gentlemen for your kind attention.







**Dr. Ana Mladenović<sup>(1)</sup>,  
Darko Kokot<sup>(1)</sup>, Alenka Mauko<sup>(1)</sup>,  
Zvonko Cotič<sup>(2)</sup>, Stanislav Lenart<sup>(1)</sup>,  
Karmen Fifer Bizjak<sup>(1)</sup>, Slovenia**

## **Waste as a Resource in Building and Civil Engineering – the Current Situation in Slovenia**

<sup>(1)</sup> Slovenian National Building and Civil Engineering  
Institute,

<sup>(2)</sup> Primorje d.d., Slovenia

E-mail: [ana.mladenovic@zag.si](mailto:ana.mladenovic@zag.si)

### **ABSTRACT**

Sustainable thinking in building and civil engineering assumes that recycling and demolition (R&D) waste, and industrial waste, is reused or recycled. Since R&D waste represents approximately 25-30 % of the total waste generated every year in Europe, this waste, together with industrial waste, should be reused in new applications, i.e. for new products which will have the same functional characteristics as if conventional materials were used. If appropriate treatments are chosen, adverse effects on the environment become negligible. This paper discusses the current situation in Slovenia, and includes some examples of good practice and research in the field in sustainable waste management. These include the use of two types of steel slag, recycled rubber, and road pavement in-situ cold recycling.

## 1. INTRODUCTION

Rapid industrial growth during recent decades has resulted in the production of a wide variety of waste that imposes severe environmental problems on mankind. On the other hand there is an increased need for reducing the negative environmental impact of conventional building materials, especially cement and concrete. A huge synergistic effect could be achieved by marrying the building sector and the waste sector, and particularly by focusing on materials that are principally derived from industrial by-products. It could be said that the field of building and civil engineering is ideal for the implementation of these materials [1, 2]. This is because, in this field, it is possible to use up large quantities of waste, since new composites frequently have better properties, and the toxic components in such waste will, in the long-term, become stabilized and fixed [3, 4].

Re-use of industrial and building waste in the construction industry is possible, desirable and permissible from the legislative aspect. The European Directive on Waste 2008/98/ES (which has been adopted by the Slovenian parliament through the Decision on Waste (Official Gazette of RS, No. 103/2011)) introduces a five-level hierarchy with regard to the treatment of waste: (a) prevention, i.e. reduction of the quantity of waste, (b) preparing for re-use, (c) recycling, (d) recovery, and (e) disposal, which is the poorest and least acceptable option. The Directive also requires that Member States adopt waste management plans and [waste prevention programmes](#). The basic idea of the Directive is that an item of waste is a material or an object which the owner cannot or does not wish to use himself, but that it is simultaneously a raw material for somebody else who has the suitable technology for re-use of the material, as well as the necessary knowledge and available markets. There are also other obligations which have been defined within the scope of the common European environmental policy (e.g. a move to a low-carbon society by the year 2050, with a planned 80 % reduction in the quantity of emitted greenhouse gasses), which make it imperative for us to accept new paradigms. The latter will encourage environmental sustainability, as well as supporting a fair policy in the field of global development, and changes in value systems and lifestyles, including a much higher degree of recycling and the better preservation of natural resources.

## 2. EXAMPLES OF GOOD PRACTICE AND CURRENT PROJECTS

This paper is concerned with the present state in Slovenia, where some cases of the routine treatment of waste have been implemented, and will also present the early results of the most promising investigations in this field. This includes the ReBirth project, which through its activities will be able to popularize and promote the use of recycled aggregates in industrial by-products in the fields of building and civil engineering.

### 2.1 Use of EAF C steel slag aggregate in wearing asphalt courses

In the 1970's and 1980's, Siemens-Martin furnace slag aggregate was used to quite a large extent, mainly in the northwestern parts of Slovenia, as an unbound layer in various construction projects, and in particular for road construction, as a substitute for natural aggregate. Due to uncontrolled and unsuitable use of this material, many road surfaces began to show severe damage, resulting in very high economic (i.e. repair and reconstruction) costs. The word "slag" got a negative connotation. It is only in recent years that there have been significant efforts to rehabilitate some types of slag as an excellent type of artificial aggregate, primarily carbon steel slag from electric arc furnaces (EAF C), in the most demanding applications in road construction.

EAF C slag is a by-product of the steel-making process in electric arc furnace. The slag is poured from the furnace in a molten state at the end of the process. About 15 to 20 % of EAF C slag per equivalent unit of steel occurs as a by-product. The principal components of this slag are calcium silicates and ferrites, together with oxides and compounds of iron, magnesium, and aluminium, which together make up 95 % of the slag. The main minerals are wüstite, polymorphic forms of the dicalcium silicate group, tricalcium silicate, brownmillerite, chromite, mayenite, gehlenite, and small quantities of free CaO and MgO. Both of the latter

components are unstable. In the presence of moisture they transform into  $\text{Ca(OH)}_2$  and/or  $\text{Mg(OH)}_2$ , which occupy a larger volume than the primary components. The result is swelling of the composite into which the slag has been placed. The slag must therefore “rest” long enough for the  $\text{CaO}$  and  $\text{MgO}$  to be transformed into stable forms. This process can be accelerated by quenching the slag. During such controlled cooling the slag can develop a micro-texture which ensures long-term toughness and roughness.

Aggregate made of EAF C steel slag has already been used to some extent in Slovenia in the construction of roads, mostly as a replacement for high-quality natural aggregates. Within the framework of the SPENS project [5, 6], several test fields were constructed, whose purpose has been to validate the suitability of this type of slag aggregate for use in wearing asphalt courses. So far, successive monitoring of the test fields has shown excellent behaviour of the asphalt layer, both with regards to its mechanical parameters and its pavement properties.

The behaviour of the test field which was constructed in 2008 on the Ljubljana-Koper motorway, on a section near Razdrto, is shown in Figure 1. The different coloured lines show the results of the continuous monitoring and chronological development of skid resistance, measured by the SCRIMTEX device. The full lines represent the condition of the steel slag section, whereas the dashed lines represent the condition of comparable sections constructed using natural volcanic aggregate (just before and after the steel slag section). The successive measurements that were performed during the 3 years after the construction of the test field show the very good skid resistance of the steel slag wearing course. When compared to the values obtained on comparable asphalt concrete sections, the steel slag also shows very good behaviour.

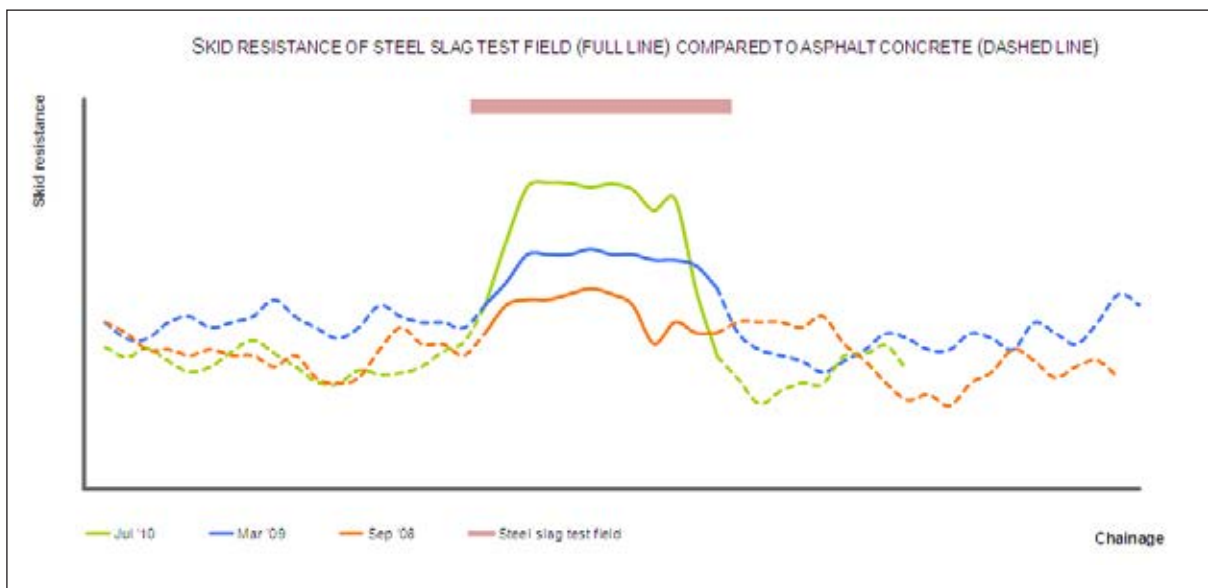

Figure 1: Development of the skid resistance of an EAF C steel slag aggregate wearing course

## 2.2 Use of poroelastic pavements made of scrap tyres

The specific feature of poroelastic road surfacing (PERS) is that it consists mainly of rubber granules obtained from recycled car tyres. These granules are sometimes supplemented by aggregate or other friction-enhancing additives. The surfacing also contains a binder to hold the mix together, which is designed in such a way that the void content is at least 20 % (usually above 30 %).

Early PERS test tracks in Japan and Sweden demonstrated that high noise reductions can be achieved (up to 12 dB(A)) in comparison with conventional dense asphalt concrete or SMA pavements. This makes PERS a feasible alternative to noise barriers or other noise-abating measures. At the same time it would benefit the environment by helping to solve the problem of over three million tons of used tyres that have to be dumped or burned every year in the twenty-seven EU Member States, resulting in ground and air pollution.

PERSUADE (<http://persuade.fehrl.org>) is an EU-subsidized project which aims at developing such an experimental poroelastic concept into a fully applicable low-noise pavement [7, 8]. The project programme

comprises extensive investigations in the laboratory in order to develop a durable mixture, the construction of seven test sections in five partner countries, monitoring of the test sections (noise, rolling resistance, skid resistance, durability, winter behaviour, etc), and a study of all conceivable environmental and economic aspects. In the two and a half years since the project began, a lot of laboratory work has been carried out to define an optimum mixture.

ZAG, the Slovenian National Building and Civil Engineering Institute, has, as a partner in the project, contributed to this work by means of laboratory tests of the durability of PERS pavements, as well as tests of the poroelastic material, focusing on tensile strength. Based on the results of these tests it was shown that the investigated PERS material had more durable behaviour, as well as higher strength, than the asphalt concrete. Figure 2 shows the differences in the tensile behaviour of asphalt concrete and PERS material.

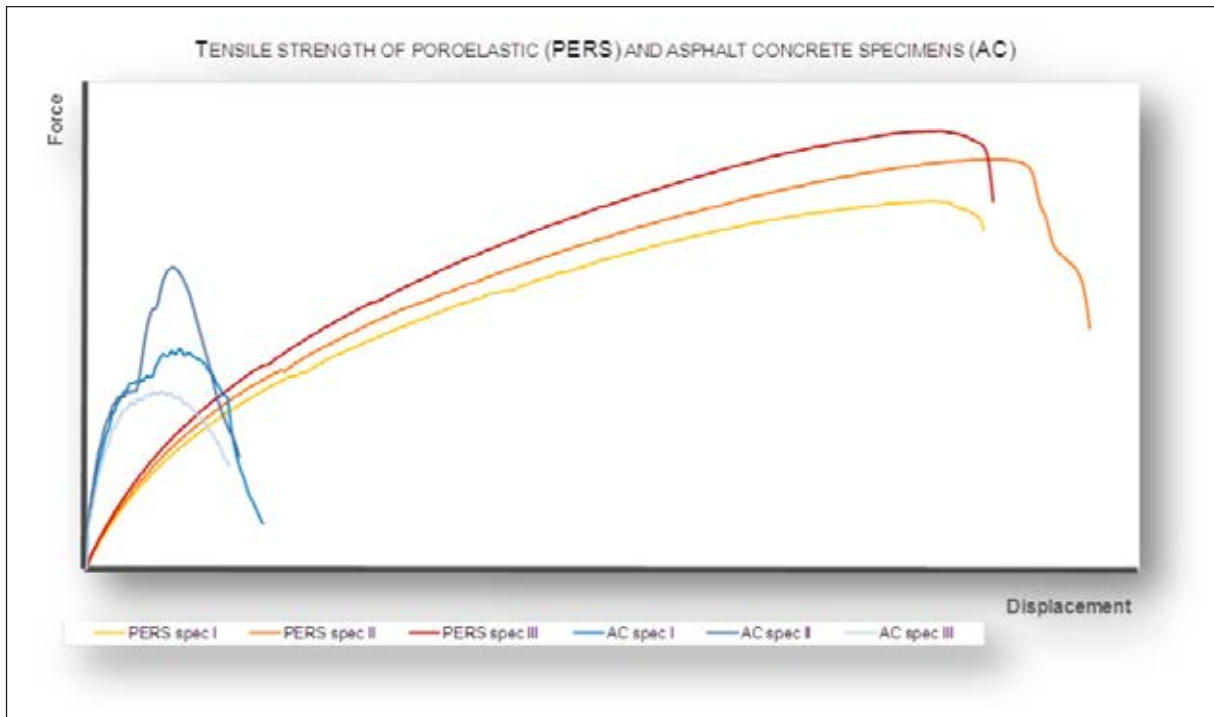

Figure 2: The measured tensile strengths of test specimens made of poroelastic and asphalt concrete

### 2.3 Cold recycling for lower energy consumption and CO<sub>2</sub> emissions during construction

The tendency of Europe's environmental policy is to become a low carbon society, and to greatly reduce greenhouse gas emissions (GHG) through a new quality of economic and environmental development. Sustainable roads are classified as safe, efficient and environmentally friendly, where the main criteria for sustainability are:

- minimization of the extraction and use of natural materials, and increasing the use of recyclable materials,
- reduction of energy consumption,
- reduction of greenhouse gas emissions,
- reduction of pollution (air, water, noise, etc.),
- increase the safety levels.

The road infrastructure construction and maintenance sectors are large consumers of energy, and they require large amounts of building materials – thus new materials (recycled/reprocessed) and new processes are essential to lower energy consumption and GHG emissions [9].

In 2011, the bituminous layers of a short stretch of a regional road Črmošnjice-Črnomelj were replaced during planned maintenance activities. Contrary to the usual replacement procedure, the authorities chose to perform these works using in-situ cold recycling with foamed bitumen. Within the scope of this case study, the works were broken down, for both maintenance alternatives, into small processes, from the extraction of raw materials and the production of mixtures, to the construction and maintenance stages. In the next step the consumed energy and greenhouse gases released to the atmosphere were calculated and compared, the results showing which alternative is more appropriate from the environmental point of view.

Road pavements usually last for between 18 and 25 years before major renovation works are needed. For the selected road section an LCA (Life Cycle Assessment) analysis [9] was made in order to compare emissions during the two maintenance alternatives:

- renovation of the asphalt layers and the unbound base layer (Rehabilitation), and
- in-situ cold recycling (Cold remix).

The calculations for each of the alternatives were broken down into three parts, corresponding to (1) material production, (2) material transportation, and (3) processes which were needed to complete the works. The results are shown in Figure 3. In all cases the CO<sub>2</sub> emissions were lower for the cold recycling method. Finally, the total CO<sub>2</sub> emitted during the maintenance works was found to be much lower for the recycling method than for the usual renovation method.

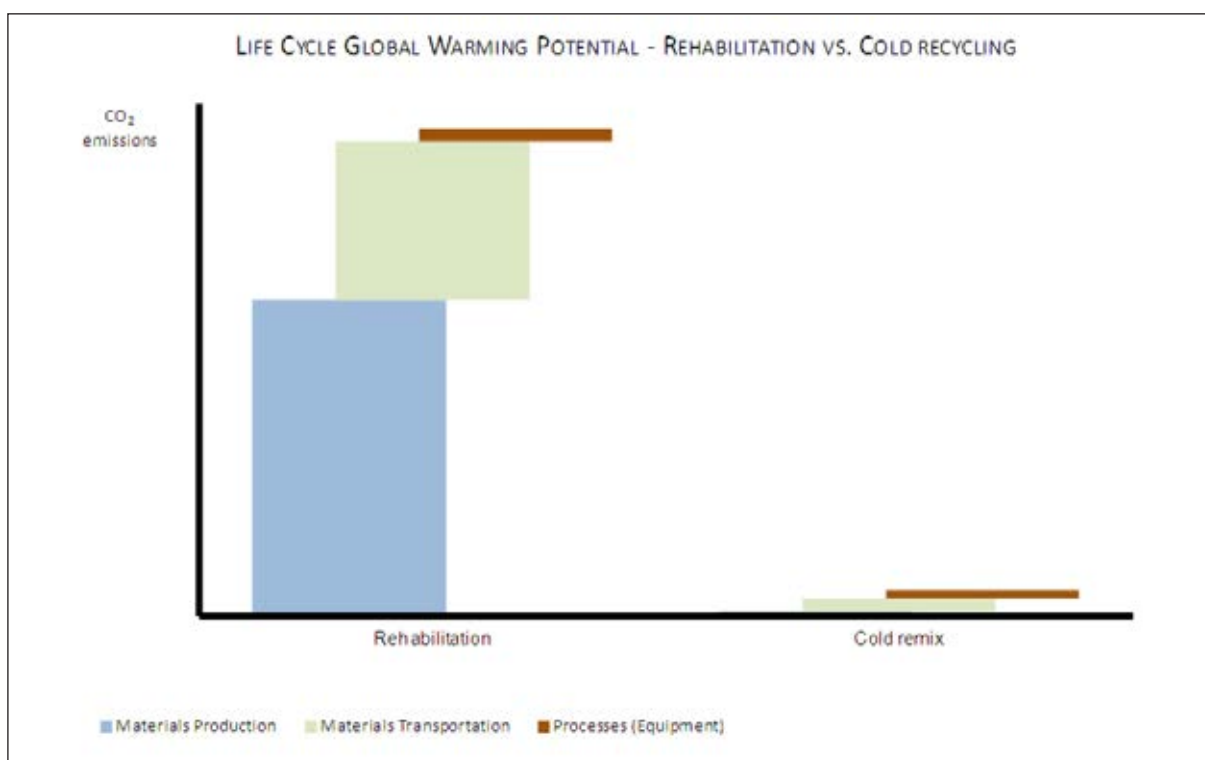

Figure 3: Global warming potential in the case of the investigated asphalt and unbound layers

## 2.4 EAF S and SMS slags

These slags occur in two processes: EAF S slag originates from electric arc furnaces (together with EAF C slag), and SMS slag is a by-product in the processes of the enrichment and further treatment of steel in secondary metallurgy. In steelworks, these different types of slag are not deposited separately, so that the final product is a mixture of both types of slags, in different proportions, depending on the type of production at the time. Such mixtures are not environmentally inert, and due to the somewhat raised

concentrations of some metals (Cr, Mo, Ba) they have the status of non-hazardous waste, for which controlled disposal is required by the legislation. During the cooling process, due to the presence of unstable dicalcium silicates disintegration of the slag into a kind of grey dust, with individual larger pieces, occurs. Since the mineral composition of the slag is such that it contains several minerals with hydraulic properties (apart from the dicalcium silicates mainly brownmillerite, as well as bredigite, alite, mayenite, gehlenite and various types of calcium aluminates - see Fig 4), this type of slag has potential as a binder, and is thus a partial alternative for conventional cements [11]. Intensive research is presently being performed into the mechanism of hydration occurring in composites with such slag, in order to determine the optimum replacement ratio of cement clinker and to find out to what extent such replacement can have an effect on the durability of new composites (resistance to sulfate corrosion, resistance to carbonation, etc.).

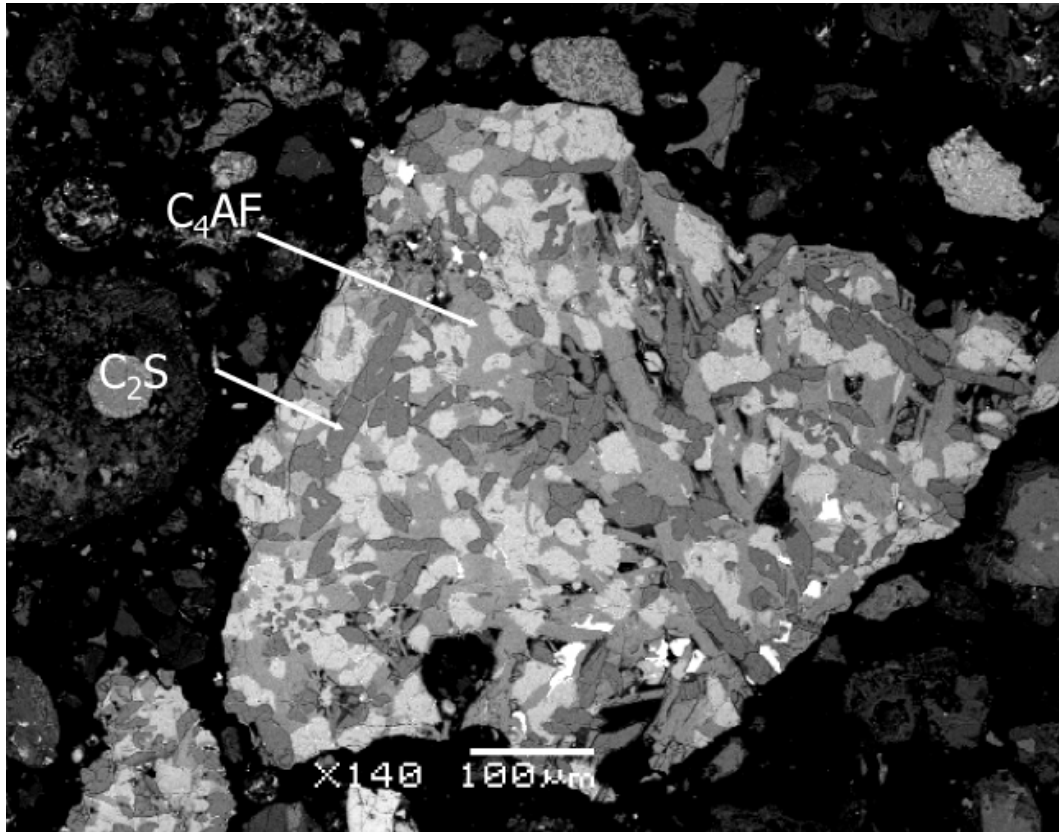

Fig 4: A grain of slag with a large proportion of hydraulic minerals – dicalcium silicate ( $\beta\text{C}_2\text{S}$ ) and brownmillerite ( $\text{C}_4\text{AF}$ )

## 2.5 The Rebirth project

The ReBirth project (Promotion of the Recycling of Industrial Waste and Building Rubble for the Construction Industry) is an information and awareness raising project, co-financed by the European Commission, LIFE+ programme [12]. The idea for the promotion and dissemination of best practice through practical demonstrations of existing technical possibilities, information on successful administrative measures and tools, such as green public procurement, environmental taxes and charges from other EU countries, through channels of communication open to professionals, state and local authorities, and to the general public, was initiated in 2010. The main objective of the ReBirth project is to stimulate the necessary trends towards an increase in the proportion of recycled industrial waste and building rubble and to create awareness of the beneficial use of recycled industrial waste and building rubble in the construction industry in Slovenia. The key information / messages to be passed to the target audience (in compliance with the EU legislation and policy) are the following:

- (1) Construction and demolition waste, as well as different types of industrial waste, is an excellent substitute for the natural materials which are used in construction, and can be even advantageous in comparison with such natural materials.
- (2) Waste materials are lost resources which burden the landscape through disposal either at legal landfills or at illegal dump sites, leading to adverse effects on biodiversity and landscape deterioration.
- (3) Natural resources need to be conserved. Fresh materials are commonly used unsustainably, leaving dents and scars in the natural landscape, and disrupting biodiversity.
- (4) The technical procedures used to process C&D wastes and industrial non-hazardous waste are well established and have been verified practically, whereas the legal requirements for waste used as recycled material for construction products need to become easier to understand, more comprehensive and more compatible.
- (5) Successful examples of market instruments, such as green public procurement, taxes and charges supporting material sustainability, exist, and can be substantiated through life cycle assessment.
- (6) The requalification of waste to raw materials is an opportunity for the development and growth of new environmental goods and services.

These messages are passed to target audiences through various activities which promote the increased application of identified waste streams as sustainable construction materials. The target audiences are construction and demolition operators, professionals working in waste recycling and industrial facilities, local and public authorities, state, specialized, regional and local media, secondary schools, universities, and the general public. Although the goals are common, each target audience requires a different set of information in order to contribute to a shifting society with a more sustainable future. Such information is distributed through conferences, workshops, demonstrations of good practice, exhibitions, papers, guidelines, and other means. The slogan "No waste here, just resources" reinforces the knowledge and awareness which is passed to the audience. It is expected that by 2015 the ReBirth project will have a significant impact on the different domains of construction and demolition waste and industrial waste recycling. It is also expected that it will be possible to achieve a permanent increase in the recycling rate for both C&D waste and industrial waste during the duration of the project, i.e. up to 10 % for C&D waste and up to 15 % for inert industrial waste, by the end of the project's duration. A turn-around in illegal dump practices is needed, i.e. no further increases in the number of illegal dump sites with C&D waste. It is also expected that the results of the project will ensure a long-term national beneficial effect in the form of a constantly increasing recycling rate, with the main goal of a 70 % recycling rate by 2020. Over the past 5 years Slovenia has had an annual demand for approximately 20 million tonnes of mineral raw materials for construction purposes. The recent crisis in the construction sector has lowered this demand, but nevertheless it is expected that approximately 1.5 % of natural materials will be saved as an impact of the project by the end of 2014. This will be seen through waste to raw material redistribution in industry and construction and demolition activities. Increased awareness will be identifiable through the test answers from training activities and awareness-raising contests, which will be held in targeted groups.

#### 4. CONCLUSIONS

The concept of sustainability in building and civil engineering requires that the present generation should live in such a way that similar life conditions will be assured for future generations, and that the environment will be degraded to the least possible extent. The re-use of waste is one of the priorities of such sustainability, since this concept will ensure the preservation of natural resources, as well as alleviating the pressure on waste disposal sites. The re-use of waste materials, if correctly implemented, should not be environmentally questionable. The consumption of energy and the carbon footprint will be reduced. These activities are permitted by the legislative framework, but it is the task of all of us to make sure that they actually occur in practice.

## REFERENCES

- [1] Kumar Mehta, P. 2009. Global concrete industry sustainability. *Concrete International*, 31, 2: 45-48.
- [2] Motz, H., Geiseler, J. 2001. Products of steel slags - an opportunity to save natural resources. *Waste Management*, 21, 3: 285- 293.
- [3] Chen, Q.Y., Tyrer, M., Hills, C.D., Yang, X.M., Carey, P. 2009. Immobilisation of heavy metals in cement-based solidification/stabilisation: A review. *Waste Management*, 29, 1: 390-403.
- [4] Paria, S., Yuet, P. K. 2006. Solidification-stabilization of organic and inorganic contaminants using portland cement: a literature review. *Environmental Reviews*, 14, 4: 217-255.
- [5] SPENS project (Sustainable Pavements for European New Member States; <http://spens.fehrl.org>)
- [6] Mladenovič, A., Bianco, L., Cotič, Z., Said, S., Tušar, M., Ravnikar Turk, M., Kokot, D.: Steel slag from electric arc furnace as a high-quality road-aggregate. In: Žnidarič, A. (Ed.). TRA, Transport Research Arena Europe 2008, Ljubljana, Slovenia, 21-24 April 2008. Greener, safer and smarter road transport for Europe, Proceedings. 2008, 7 pages.
- [7] Goubert, L, Sandberg, U. The poro-elastic road surface (PERS): a powerful tool for traffic noise reduction, PIARC XXIVth World Road Congress, Mexico city, 26.-30. September 2011
- [8] Kokot, D. Comparing stability of poroelastic pavements with a cement screed- and a sand bedding layer. In: BISMOR, Dariusz (Ed.). 16th International Congress on Sound and Vibration [also] ICSV16 Krakow, Poland, 5-9 July 2009. Recent developments in acoustics, noise and vibration : proceedings of the 16th International Congress on Sound and Vibration [also] ICSV16, Krakow, Poland, 5-9 July 2009. Gliwice, Poland: The International Institute of Acoustics and Vibration, 2009, paper 272 (8 p.).
- [9] Best Practice guide for the dismantling of asphalt roads and use of recycled materials in asphalt layers, EU project DIRECT\_MAT (Dismantling and RECYcling Techniques for road MATerials – Sharing knowledge and practices) Deliverable D19, 2011
- [10] Bingisdotter, H. 2005. Life cycle assessment model for road construction and use of residues from waste incineration. Ph.D. Thesis, DTU.
- [11] Adolfson, D., Robinson, R., Enegrö, F., Björkman, B. 2011. Influence of mineralogy on the hydraulic properties of ladle slag. *Cement and Concrete Research*, 41, 8: 865-871.
- [12] ReBirth project (Promotion of the Recycling of Industrial Waste and Building Rubble for the Construction Industry, <http://www.re-birth.eu>)





**Dr. Marjana Šijanec Zavrl,  
Dr. Henrik Gjerkeš,  
M. Sc., Miha Tomšič,  
Slovenia**

## **Integration of Nearly Zero Energy Buildings in Sustainable Networks – a Challenge for Sustainable Building Stock**

Building and Civil Engineering Institute ZRMK, Slovenia

E-mail: [marjana.sijanec@gi-zrmk.si](mailto:marjana.sijanec@gi-zrmk.si)  
[henrik.gjerkes@gi-zrmk.si](mailto:henrik.gjerkes@gi-zrmk.si) / [miha.tomsic@gi-zrmk.si](mailto:miha.tomsic@gi-zrmk.si)

### **ABSTRACT**

Nearly zero energy buildings (nZEB) are the key priority of the 2020 climate and energy policy. Directive EPBD – Recast (2010/31/EU) required the implementation of cost optimal minimum requirements for new buildings and renovation of existing buildings and by 2020 also the upgrade of building regulation with nZEB targets. In order to successfully meet this requirement the energy efficient buildings and systems have to be integrated in the sustainable energy supply networks that are as rule based on the local and renewable resources. In sustainable energy action plans (SEAPs developed under EU Covenant of Mayors) EU municipalities are committed to substantial reduction of CO<sub>2</sub> emissions preferably by self-sufficient energy supply. This contribution is focused on Slovenian national nZEB criteria and the potential of local energy supply and national sustainable energy networks in order to meet EPBD Recast targets for new buildings and to make the renovation of existing buildings more sustainable. Moreover, the role of the above concept in the green (public) procurement rules will be evaluated with respect to the improvement of the built environment sustainability.

## INTRODUCTION

The implementation of the requirements of Directive EPBD – Recast (2010/31/EU) on nearly zero energy buildings (nZEB) has initiated various approaches in EU member states (MS). According to EPBD Recast nZEB must have very high energy performance while nearly zero or very low energy demand must be covered to a very significant amount by energy from renewable energy sources (RES) including energy produced by renewable sources produced on-site or nearby. By 2020 (by 2018 for public buildings) all new buildings will have to correspond to the national nZEB definition. The EU overview of the drafted nZEB regulation prepared under IEE CA EPBD III project showed [1], that three main questions were essential for formulation of nZEB criteria: (a) How to define “nearly” zero energy demand; (b) How “nearby” are renewable allowed; (c) What “energy aspects” are included in nZEB definition. In addition, the energy efficiency minimum requirements of the building codes must be based on cost effectiveness from the life-cycle perspective, moreover the requirements may only go beyond the threshold of cost effectiveness.

## ENERGY EFFICIENCY CHALLENGE FOR SLOVENIAN BUILDINGS

Slovenia has implemented EPBD [2] based minimum requirements for energy efficient buildings in the year 2002, and accepted two revisions in 2008 and 2010 building codes. In 2002 regulation the minimum requirements for new buildings and major renovations were expressed by maximum energy needs for heating (PTZURES 2002) and complemented with maximum U values; in 2008 regulation (PURES 2008) an intensive reduction of transmission losses through the building envelope as well as new requirements on obligatory 25% use of RES in final energy use were introduced, and more recently, as a part of the implementation of EPBD Recast, the latest 2010 building code (PURES 2010) put focus also on the calculation of primary energy and CO<sub>2</sub> indicators, set additional minimum requirements in terms for primary energy for heating, limited the heating and cooling needs and added many new minimum requirements for energy systems.

The process of setting national minimum requirements was based on the advanced but market available technologies for energy efficient buildings and defined in accordance with the national targets and obligations set by the 20-20-20 policy.

Slovenia has adopted a target to achieve a 1% annual energy savings or 9% in the period from 2008 to 2016 (Slovenian NEEAP, in line with ESD directive). Furthermore, a very ambitious target (binding by RES directive) – to achieve a 25% share of renewables in gross final energy use (currently 15%) by 2020 and 10% share of renewables in final energy consumption in transport, was accepted. In the new National energy program (NEP 2030, in public hearing) is thus based on a number of operational objectives by 2030, i.e. improvement of energy efficiency to 20% by 2020 (27% by 2030), 25% RES by 2020 (30% by 2030), reduction of GHG from fuel burning by 18% to 2030. The above targets assume gradual increase of the share of near-zero energy buildings among new and renovated buildings by 2020 and in the public sector until 2018, moreover it is planned to reduce the energy costs in the public sector by 40 million / year by 2015, 85 million / year to 2020 and EUR 130 million / year until the 2030. These objectives will be implemented through the measures of the new NEEAP 2010-2016, which has planned among other measures also a large scheme of financial incentives for energy efficient renovation and sustainable residential buildings.

## COST OPTIMALITY OF MINIMUM REQUIREMENTS

In order to investigate the cost optimality of minimum requirements in Slovenian building code the national study [3] was initiated based on the EC comparative methodology framework for calculating cost optimal levels of minimum energy performance requirements for buildings and its elements. Firstly the effort was focused on the cost optimality at financial level (with consideration of the end consumer perspective),

aiming at definition of cost optimum minimum requirements for new single family houses (SFH are the most numerous and represent 75% of the residential sector floor area, and 55% of the entire Slovenian building sector).

The assumption of the calculation period of 30 years for the residential buildings differs from the building lifetime of 60 years defined in the national regulation for maintenance of residential buildings, although in practice the most common period for the major renovation in residential sector is 30-40 years. The other boundary conditions are based on the National energy program (NEP 2030) that defined the energy scenarios comprising also the assumption on the growth of energy prices and the anticipated CO<sub>2</sub> prices based on emission trading system for calculation at the macroeconomic level (in line also with the figures in Annex I of the framework methodology). The recent establishment of the national real-estate data base (REN 2008) gave the necessary support for categorization of the building stock according to the type of use, the period of construction, and the main architectural characteristics as well as to the implemented renovation measures. Thus the selection of the reference buildings was based on the typology of the Slovenian national residential building stock elaborated in the IEE project TABULA [4]. The typology of the non-residential building stock has not been elaborated yet, although there are some early activities going on in the country it is clear that the variety of non-residential buildings is much bigger than in residential sector. The reference residential buildings are thus example buildings, while non-residential are expected to be virtual buildings based on the available relevant indicators from the national real-estate registry.

Methodology allows the MS to complement the framework methodology in certain elements. Economic lifecycles of the building and building elements are assumed in line with findings of IEE LCC DATA project, national regulation on maintenance of buildings and building elements and EN 15459: 2007 (for energy systems). The comparison with related EU studies on LCC showed that the lifetime of building elements may differ in a significant range. The discount rates of 3% and 5% (required in the national procurement documentation) are taken in the consideration. The cost categories for LCC are based on the prEN 15643-4 (and standardization from CEN/TC 350) with consideration to the Annex I of methodology framework (i.e. disposal costs were excluded, the costs that are the same for all variants and costs that have no influence on energy performance of a building were also omitted). Primary energy factors are determined in the national regulation, i.e. building code PURES 2010. Energy performance is determined according to the national calculation methodology which is based on EN ISO 13790 and CEN EPBD standards [2]. The climate in central Slovenia may be considered relevant for the majority of settlements in the country, only the small coastal area has milder, Mediterranean climate.

At this stage the preliminary results can be discussed only for a single family reference building (SFH). For SFH with a useful floor area of 150 m<sup>2</sup> a group of 130 variants was defined, alternatives refer to different insulation thickness (5 – 35 cm), windows with thermal transmission between 1,2 W/m<sup>2</sup>K and 0,8 W/m<sup>2</sup>K, natural and mechanical ventilation with heat recovery, and the energy systems with condensing gas boiler, wood pellet biomass boiler, heat pump ground/water, heat pump air/water, solar collectors for domestic hot water (DHW) and/or space heating.

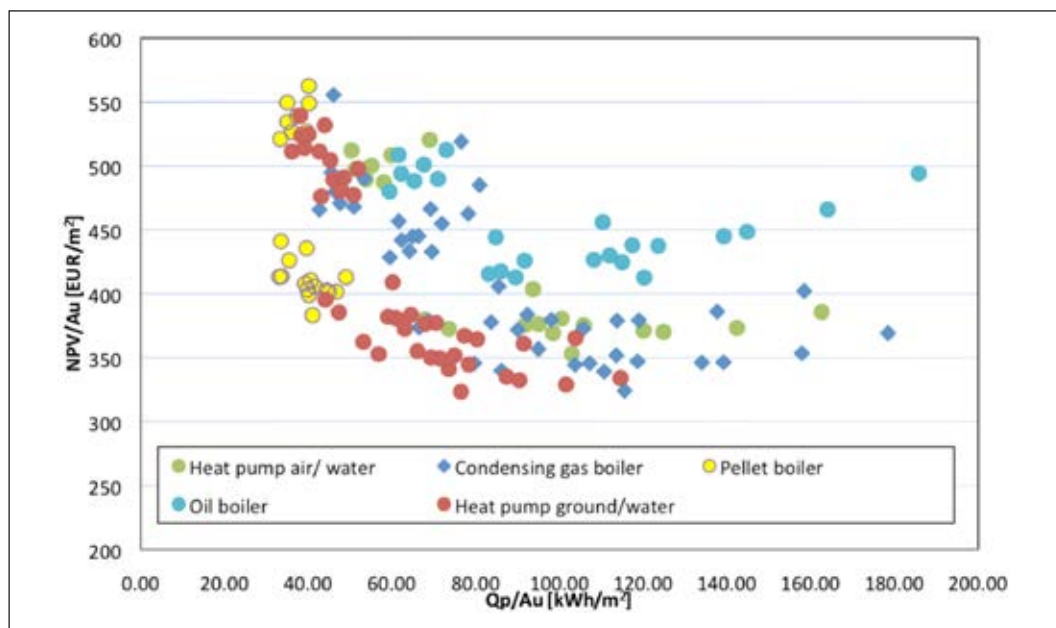

Figure 1: Net present value of the energy related investment, running and maintenance costs for a typical new single family building with various energy efficiency levels, energy systems and energy sources (discount rate 3%, 30 years life-time). Net present value (NPV/Au) is presented depending of the primary energy use ( $Q_p/A_u$ ) to enable to identification of cost optimal building design. [3]

The results also clearly demonstrate that the minimum requirements set for new residential buildings – single family houses - in PURES 2008 and PURES 2010 building codes are more severe than the minimum requirements corresponding to the cost optimal level, mainly due to the national energy and climate policy targets in the building sector. Variants in compliance with the 2010 national building codes are based on the implementation of insulation levels and windows resulting in the overall specific transmission heat losses of the envelope  $H_t'$  below  $0,4 \text{ W/m}^2\text{K}$ , use of condensing gas boiler and solar collectors for DHW and other systems like heat pump or biomass boilers that lead to the share of over 25% of RES in delivered energy.

The lowest NPV is demonstrated in variants with very good envelope insulation (around 20 cm), windows with double low-e glazing, natural ventilation and condensing gas boiler, variants with heat pumps alternatively combined with solar collectors are close competitors. Due to the relatively flat cost optimality curves the final conclusion on cost optimal combination of envelope insulation level and energy systems is still pending and needs additional sensitivity analyses of core parameters (like market specific prices of systems).

## SUSTAINABLE HEATING

Due to the relatively cold climate (3300 DD) heating is still the main part of energy use in Slovenian building sector. In year 2009, households in Slovenia used 13.713 GWh of energy, most of it, i.e. 11.188 GWh, for heating and domestic hot water (DHW). The most common energy source for heating and DHW were wooden fuels with 33 % share, followed by fuel oil with 22 %, natural gas and district heating with 8 %, and electricity with 7 % [5]. The share of renewable energy sources (RES) is rising, especially with different forms of wooden fuels and with rising of the number of district heating systems. The role of heat pumps, which transform renewable energy from environment (air, ground,...), is increasing and became important energy source in sector heating. Therefore, from the sustainability point of view, the trends of the share of RES in power generation on national level are very important for meeting the targets of nZEB and sustainable building.

Power generation in Slovenia stood at 15,16 and 15,32 TWh in years 2009 and 2010, respectively [6]. Distribution between energy sources is showed in Figure 2. In total power generation in year 2010, the share of RES, which includes hydro power plants and small qualified producers, was 33,3 %.

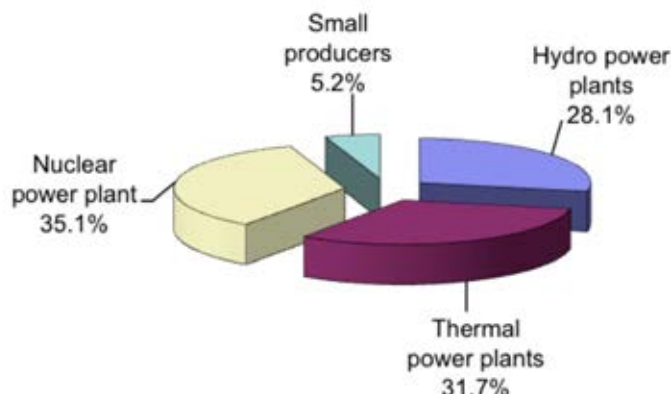

Figure 2. Distribution between energy sources in Slovenia in year 2010 [7].

## TRENDS IN RES UTILIZATION FOR POWER GENERATION

As shown in Fig. 2, the share of RES in total power generation in year 2010 was 5,2 %. Table 1 shows, that the largest share between RES with 67,2 % have small and medium hydro power plants, which produced in hydrologic favourable year 2010 12,3 % more electricity than the year before. Despite the relatively low share of installed capacity of 1 %, the wood biomass power plants generated as much as 14 % of RES electricity, followed by biogas power plants with 13,4 %, and municipal waste power plants, which combine wastewater treatment plant gas and landfill gas power plants. Beside the wind power plants, which are still of marginal importance, index 2010/2011 shows the largest increase of more than 300 % in production at solar power plants. However, at installed capacity of 6,2 %, the solar power plants provided only 1,4 % of all electricity produced from RES in year 2011.

Table 1. Installed capacity of RES power plants in Slovenia [7].

Power plant	year 2009			year 2010			Index 2010/2009
	Power generation [kWh]	Share in RES [%]	Share in total production [%]	Power generation [kWh]	Share in RES [%]	Share in total production [%]	
Hydro (up to 10 MW)	430.239.719	66,612	2,981	483.033.860	67,247	3,472	112,3
Biomass	97.943.961	15,164	0,679	100.756.071	14,027	0,724	102,9
Wind	218	0,000	0,000	10.666	0,001	0,000	4892,7
Solar	2.528.978	0,392	0,018	10.305.110	1,435	0,074	407,5
Biogas	78.276.053	12,119	0,542	96.269.047	13,402	0,692	123,0
Biomass co-burning (5 % to 90 %)	6.403.404	0,991	0,044	0	0,000	0,000	0,0
Municipal waste	30.501.352	4,722	0,211	27.918.645	3,887	0,201	91,5
<b>Total RES</b>	<b>645.893.685</b>	<b>100,000</b>	<b>4,476</b>	<b>718.293.399</b>	<b>100,000</b>	<b>5,162</b>	<b>111,2</b>

Considering natural assets in Slovenia and current stage of RES technologies development, the most appropriate RES for power generation in Slovenia seems to be wood biomass and hydropower. Sun is free and evenly distributed energy source, but also exponential growth of installed capacity of solar power plants in Slovenia, exceeding 6 % of all RES capacity in year 2011 and high subsidy rates of more than 10 %, did not provide more than 1,4 % of produced electricity from RES. Technology of municipal waste utilization is also very promising, with endless supply, but requires complex and interrelated system, which inhibits its faster deployment. An anaerobic fermentation of organic matter for biogas production has great potential, well developed technology and all prerequisites to be a key technology for sustainable energy self-supply. Hydropower is already well utilized in Slovenia and there is only a few opportunities left for further increasing the capacities of hydro power plants without coming into conflict with sustainable conservation of nature. In contrast to that, in Slovenia there is an abundance of wood, which has a great development potential. Wood is already recognized as a strategic source, which should be principally used in wood industry for products with high added value, and as a byproduct for energy production.

In one way or another, rational synergy between still largely unexploited potentials of some RES and cost-energy efficiency optimisation could become one of the cornerstones for sustainable building and also for successful development of Slovenia.

## CONCLUSIONS

Slovenian building codes have traditionally considered energy efficient building as a part of construction process governed by construction legislation. The transposition of nZEB principle into the real life demonstrated a need for integration of building design and energy planning. Sustainable energy planning is an opportunity for municipalities to create favourable boundary conditions for nZEB. It is expected that the solutions for decrease of the energy demand in buildings, which are often beyond the cost-optimum level, will be compensated not only with RES on site and sustainable energy self-supply (city, municipality, region,...), but also with growing share of green energy in national energy networks.

## LITERATURE

1. MALDONADO, Eduardo, Member states approaches EPBD, World Sustainable Energy Days 2012, Nearly Zero Energy Buildings Conference, Wels, March 1, 2012
2. Implementing Energy Performance of Buildings Directive (EPBD), European Commission, 2011
3. ŠIJANEC-ZAVRL, Marjana, SKUBIC, Marta, RAKUŠČEK, Andraž, GJERKEŠ, Henrik, POTOČAR, Erik. Practical implementation of cost-optimal regulation for establishing national minimum requirements of Slovenia. V: World Sustainable Energy Days, Wels, 29 February - 2 March, 2012. Proceedings. Wels: [O. Ö. Energiesparverband, Linz], 2012, [13] 3 pp.
4. Diefenbach, N., Loga, T., Dascalaki, E., Balaras, C., Šijanec Zavrl, M., Rakušček, A., Corrado, V., Corgnati, S., Ballarini, I., Renders, N., Vimmr, T., B. Wittchen, K., Kragh, J., Application of Building Typologies for Modelling the Energy Balance of the Residential Building Stock – TABULA Thematic Report N° 2 – ISBN 978-3-941140-23-3, Februar 2012
5. Energy consumption in households, Slovenia, Statistical Office of the Republic of Slovenia, 2011
6. Statistical Yearbook of the Republic of Slovenia, Statistical Office of the Republic of Slovenia, 2010
7. GJERKEŠ, Henrik, PAPLER, Drago, ŠIJANEC-ZAVRL, Marjana. Sustainable development of power generation in Slovenia. V: GOLOBIČ, Iztok (ur.), CIMERMAN, Franc (ur.). Development and implementation of enhanced technologies 2011 : proceedings of the 3rd AMES International Conference, Ljubljana, Slovenia, November 29th-30th, 2011. 1st ed. Ljubljana: Association of Mechanical Engineers of Slovenia - AMES, 2011



## Miloš Todorović, Slovenia

### Benefits of BIM and a Multidisciplinary Collaborative Environment

University of Ljubljana, Faculty of Civil Engineering  
and Geodesy

E-mail: [milos@bim.si](mailto:milos@bim.si)

#### ABSTRACT

Integrated Project Delivery (IPD) and Building Information Modeling (BIM) are becoming a reality in building design and delivery methods worldwide. Both of them have been also a major part of the PBL Lab and AEC Global Teamwork course at Stanford University, directed by Dr. Renate Fruchter since 1993. Every year the course shows great examples of all the possibilities of today's technology, bringing future's building design processes and products. Milos Todorovic, researcher from Faculty of Civil and Geodetic Engineering, University of Ljubljana, participated in 2012 course. With his team he won the Swinerton Sustainability Challenge for their design. The workshop will be based on presenting IPD and BIM team workflows with examples from PBL Lab and other projects, providing proof of true benefits of shifting outdated 2D and non-collaborative design processes and workflows to IPD and BIM based ones.

## INTRODUCTION

"You are the change agents!" was the energetic and enthusiastic welcoming note to all the participants by Dr. Renate Fruchter from Stanford University. In January 2012 already a 19<sup>th</sup> generation of graduate and undergraduate students, faculty, and industry practitioners gathered together to join in Dr. Fruchter's and her PBL Lab's "AEC Global Teamwork Course" – a multi-disciplinary, collaborative and geographically distributed working and learning environment. PBL (Problem/Project/Product/Process/People-Based Learning) is a unique learning experience with a *mission to prepare the next generation of AEC professionals who know how to team up with professionals from other disciplines worldwide and leverage the advantages of innovative collaboration technologies to produce higher quality products, faster, more economical, and environmentally friendly. The objective is a sustained effort in an integrated research and curriculum to develop, test, deploy, and assess radically new collaboration technologies, workspaces, processes, learning and teamwork models that support cross-disciplinary, geographically distributed teams.* [4][2].



Most of us can imagine or agree that the education and the whole experience of being involved in projects or courses at Stanford University is on a very high level and not even comparable with our, Slovenian, educational standards. The lectures and interactions with its typical American positive philosophy, enthusiasm and engagement, actually do impact on your working energy, whether you like it or not. Sometimes there might be a lack of negative constructive criticism in between working process, but overall positive comments do improve it. Industry involvement in education is reasonable and correct, which the participants had quickly realized as well. At times it seemed that the interest of industry partners and mentors is even at a higher level than the one of students. That is somewhat logical, as they are the ones who observe and test the new technologies and processes with the interest of implementing those in their own practices if proven beneficial.

Main essence of the course is geographically disperse teamwork, so participants come from all over the world – from Europe, Asia, Central to North America. Since 1993 more than 20 universities have participated. University of Ljubljana is participating in the program since 1999, when the first participant was Dr. Tomo Cerovšek, from Faculty of Civil and Geodetic Engineering, and now also the head coordinator of the program



at the University. Faculty of Architecture is also involved, where Anja Jutraž is responsible for the coordination. This year's participants from University of Ljubljana were student of architecture Janž Omerzu and author Miloš Todorović, researcher from Faculty of Civil and Geodetic Engineering. Both, with their own teams won the two program's challenges.

## COURSE WORKFLOW

As a simulation of real-case scenario, participants of the course in a teamwork environment virtually design a classroom and lab facility with given project requirements. Education focuses on acquisition of computer, coordination and communication skills with discipline knowledge application to design, model, plan, schedule and estimate cost of the given facility. Also participants learn to manage the knowledge created by the team and document the evolution of product, process, and ICT use.

At the beginning there is a formation of project design groups, which consists of an architect, at least two structural engineers, one or two construction managers, MEP engineer and/or life-cycle facility manager. Each group has an owner of the virtual building to be designed who gives out all the project requirements and restrictions. Projects are group specific with different project requirements. Through the years they stay the same, so the development of technologies and final results can be recorded as well. To make the work even more interesting there are two award challenges announced at the beginning. There are two companies involved in it – since 2006 Swinerton Incorporated opens a Sustainability Challenge Competition Theme, and since 2009 adding a parallel challenge related to teamwork is DPR Construction. This year's Swinerton challenge was based on biomimicry, while DPR's was covering POP (*Product-Organization-Process*).

There are two project phases based on winter and spring quarter. By the end of the winter quarter project team works in conceptual environment delivering two alternative construction solutions for each of two given footprints. Based on the decision matrix the team then evaluates each of the four concepts and decides which of them is a winning solution for further development in the spring quarter. The work then focuses on further design iterations, analysis, detailing and multi-disciplinary modeling, 3D, 4D, nD modeling, and cost-benefit analysis.

All of the work in the course is done over the internet. Participants meet in person at Stanford only twice, first in January at kick-off event, and secondly at the final project presentation in May. Because of the geographic team-member dispersion, it is important to establish mutual respect, work consistency and compliance of organization to achieve effective workflow. It is usually recommended that one or two team members take over the control of team organization, establishment of workflow protocols and standards, meeting agendas and reports, etc. Clear specifications, protocols and file naming conventions should be defined also for the software being used for communication and data exchange. "There is no I in the team!" is a basic rule, which needs to be followed – everything is done in the common good, decisions, mistakes and rewards are shared within the team, individual falls out of the equation.

IPD (Integrated Project Delivery) is the main core of project's workflow. It has also been the theme of DPR's challenge in 2010. *IPD is a project delivery approach that integrates people, systems, business structures and practices into a process that collaboratively harnesses the talents and insights of all participants to reduce waste and optimize efficiency through all phases of design, fabrication and construction* [1]. In recent years project design is also being based on BIM (Building Information Modeling) and emphasizing the shift forward towards HiDefBIM (High Definition BIM), which as a disruptive technology should show the true benefits in new design processes.

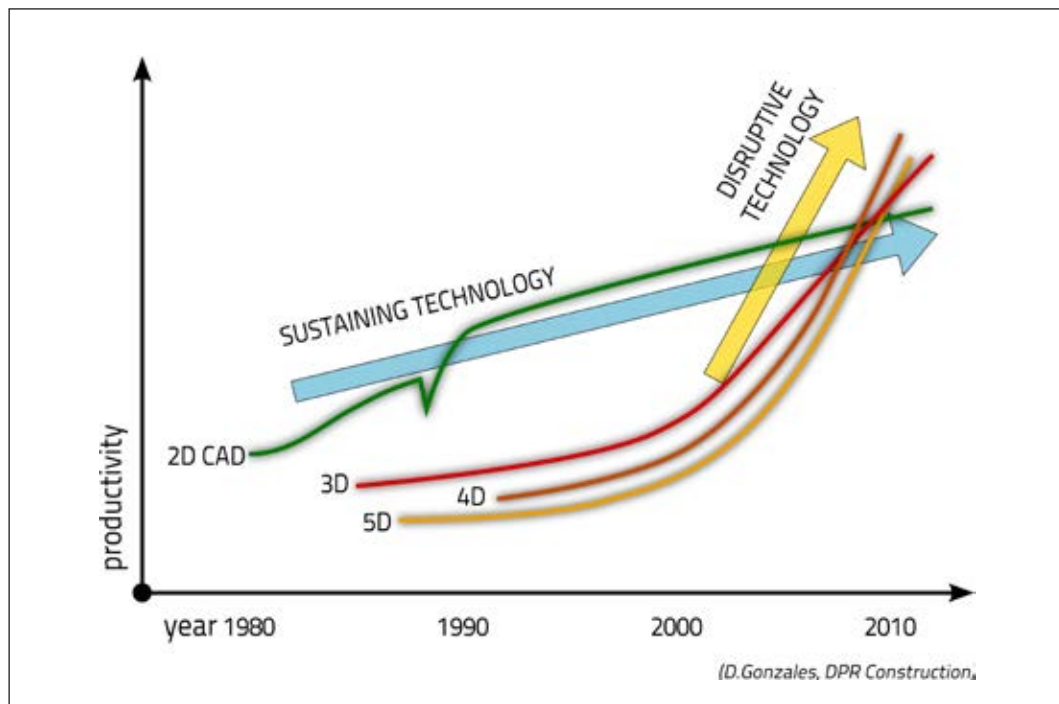

Last year's DPR challenge was TVD (Target Value Design). Based on it, at project start the team sets and focuses on targets or goal to be achieved with the design and final product. The team sets the target and intends to hit the center point of it to get the most reward points. It is a team-based approach of work and it was a logical and correct approach also in this year's teamwork. DPR's challenge this year upgraded teamwork further more with a new challenge theme called POP (Product-Organization-Process). POP is again a fairly new term in the industry, but it shouldn't be left behind as it has a lot of benefits if understood and treated right. *A project manager can control three kinds of things: the design of the product to be built, the design of the organization that does the design and construction, and the design and the design-construction process that the organization follows* [7]. Even a rough and simple description like this one, probably causes difficulties in understanding, never the less the fact that deeper meaning and understanding is hidden at the background. But that was also the whole point of the challenge – participants were pushed with it to think on their own, trying to figure out new approaches and understanding of POP. Self-initiative, new and alternative approaches are the main meanings of the course. As Gregory Luth, one of the industry mentors concluded one of his presentations: "Don't work with industry standard values, figure out new and better things!" The winner of POP challenge was team Atlantic, where Janž Omerzu was one of the members.

One of the core aspects of the course is also sustainable design. Even more from 2006 when the first Swinerton Sustainable Challenge was announced. This year's topic covered biomimicry, the examination of nature and its systems, processes and elements to take inspiration from in order to implement it in design. To achieve biomimicry in the design author's team implemented the form and processes of a pine cone in their building and with that won the challenge. That is how University of Ljubljana achieved a double win in this year's course.

## “PINE CONE” BY RIDGERS



171

MILOŠ TODOROVIĆ

Team in which the author was included was named Ridge. Team members were: Kristian Fosholt from Stanford University as an architect, Maryanne Wachter also from Stanford University and Annemarie Herrmann from Bauhaus University Weimar, Germany, both playing a role of structural engineers, Bedriye Kaplan, from Technical University of Denmark as MEP engineer and author Milos Todorovic, from University of Ljubljana as a team's construction manager. This article is too short to show all the team's work and design process, so only few of them will be pointed out. Detailed project presentations from all teams involved can be found in the AEC Project Gallery at <http://pbl.stanford.edu/AEC%20projects/projpage.htm>.

Team decided to set out simple and basic target values of their design (TVDs), as they could act strong in final outcome of the project. Natural and local TVDs focused on natural and local resources, community integration and social aspects of the design. Despite being a logical one of the design itself at the course, team chosen also the team process as their TVD, to stay even more focused on it. In order to follow team's natural and local TVDs team did a research on Nevada State symbolism and found out that Bristlecone Pine (believed to be the oldest living organism on Earth) is a Nevada State tree. That was the starting point of implementing a pine cone idea to the design in order to achieve biomimicral approach. The form of a pine cone was the first thing the architect was thinking about. Ideas of solar shading panels shaped like a pine cone emerged, and then the pine cone form took over the whole building form. Integration of form was included also in the interior, where the idea of ceiling acoustic panels with MEP integration was presented as well. With a solid formal biomimicry, the team focused then also on functionally integrated idea. First the idea of water collection with roof forms arose, which was then also integrated in the design. After realizing that the collection of water is not really a pine cone's function, the team researched again, but kept the water collection system as it was beneficial to the building design. Pine cones expand and contract in order to adapt to the environmental conditions. In order to mimic that, team developed an idea to use adaptive systems to naturally ventilate the building.

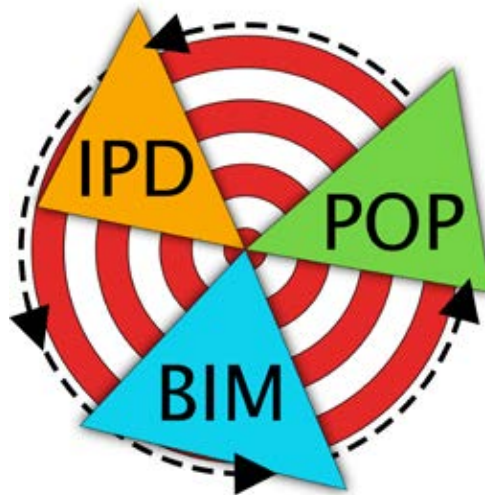

After a rough start in terms of team process and relationships, the team was on a verge of a breakdown by week 4 of team collaboration. Team communication can be problematic as default, but when we add also the factor of geographical dispersion of team members, chances that something will go wrong are even bigger. Communication was weak, responsibilities were passed on from one to another, work results were not seen, and similar. To avoid catastrophe one of the structural engineers and construction manager took over the control of team organization, meeting protocols and agendas, and establishment of team member's tasks and duties. The construction manager formed also a weekly survey which recorded the level of team energy for the past weeks. The first part of the survey recorded general team and personal energy level, while the second part recorded ratings of each discipline's deliverables. Especially the second part served as a self-reflecting observation of work, where low ratings could serve as a motivation for better work in the following week, or high rates could be interpreted as a confirmation of hard work being done in past week. All this points out on one major topic that needs to be addressed with the IPD and BIM implementation – the importance of social factor in design environment, which hasn't been addressed much in current design practice.

As the team is geographically dispersed it is important to have as many virtual working environments established as possible, so the social interactions between members are not broken. At least at the beginning it is recommended to use video conferencing tools, and not just audio ones, as this help a lot in establishing a friendlier working environment. Main software tools that the team used for communication were GoToMeeting and Skype. First one for team meetings, as the tool enables also screen sharing and remote control of applications between members, and the second one for quick chat and collaboration when users were online. For file sharing the team used a web application Box.com, which in addition of document sharing, enables also discussion (forum) possibilities and integration of certain organization applications as i.e. Google Docs. This was beneficial, as the i.e. meeting agendas and reports could be written live by any and more team members at the same time while the meeting was taking place.

Special working experience and environment was enabled with the use of 3D ICC OpenQwaq software. The team had two virtual environment established there – virtual office and virtual lawn. Each team member was represented with an avatar, so the experience could be more personal. Virtual office was used mainly for bigger team meetings where the owners also participated and the team could use the space in a manner of a showroom and guide them through the project phases or topics which needed to be addressed. Even more exciting was the use of the lawn where the team set up a building model, which can then be used for guided walkthroughs and experience a future built environment. It's not a photorealistic experience, but more important are the feel of the space you are walking through and the possibility of observation and search for problematic areas. When the whole team was walking through a corridor at the same time, they were immediately aware if there is enough space provided or not.

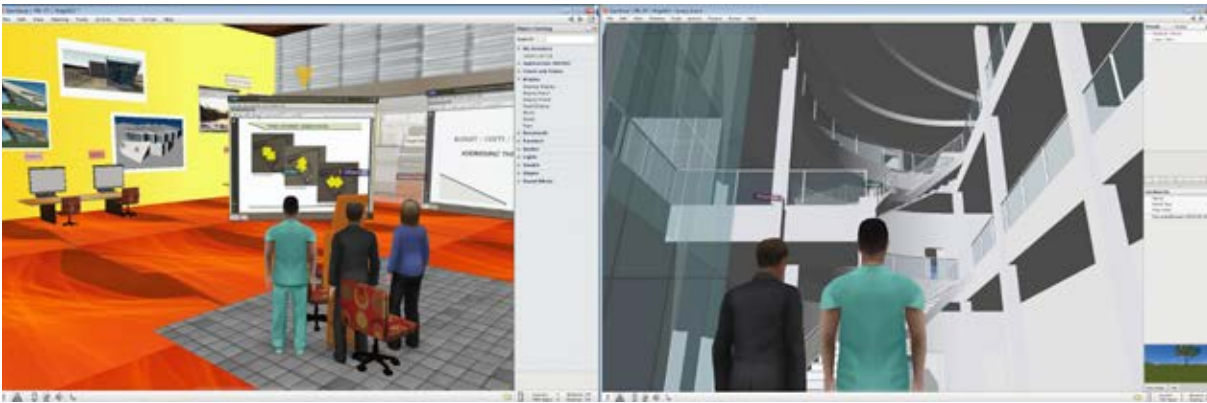

A special surprise for the mentors at the final presentation was the live photorealistic walkthrough that the team showed using Stadia software. The software uses the Revit model of the building to render and prepare a self-executable (.exe) file which enables a first person experience, similar to gaming environments, where the user can walk through a virtual space and explore the building. The walkthrough has a high added value to the project design, especially looking through the eyes of an investor or an owner, who can walk through his/hers building before it is even built.



## CONCLUSIONS

New approaches, new technologies, new people. Every year Dr. Fructer with the help of university and industry mentors and partners proves that time goes on, and that the one that we are living in had in some cases slightly slowed down too much. Results of teamwork on virtual projects every year show that keeping up with the time and technology development is something that is manageable and doable. If this can be proven by young engineers with little or no working experience, imagine the possibilities that could be achieved by professionals with real-life experience.

Clear and simple argument on why we should forget current design practices and transfer to IPD and BIM based ones, was made by David Bendett from Perkins+Will: "It's just not fun!" Probably every participant of the course could not agree more with this statement. When the organizational part of the design practice is established, the fun begins – everybody is working and breathing as a team, work becomes more effective and final products become better. It's time for IPD and BIM.

## REFERENCES

- AIA California Council, 2007. Integrated Project Delivery. A Working Definition. Version 2 Updated 06.13.2007.
- Fructer, R. 1999. A/E/C Teamwork: A Collaborative Design and Learning Space. Journal of Computing in Civil Engineering, 13, p. 261-269.

- Fruchter, R. 2001. Dimensions of Teamwork Education. International Journal of Engineering Education (IJEE), Vol.17, Nos. 4 and 5.
- Fruchter, R. Architecture/Engineering/Construction (AEC) Global Teamwork. <http://pbl.stanford.edu/Research/ResearchILE.html> (junij, 2012)
- Fructer R., Ivanov P.V. 2011. Agile IPD Production Plans as an Engine of Process Change. ASCE Computing in Civil Engineering Conference, Miami, 2011.
- Hardin, B. 2009. BIM and Construction Management. Wiley Publishing, Inc.
- Kunz J., Fischer M 2011. Virtual Design and Construction: Themes, Case Studies and Implementation Suggestions. CIFE Working Paper #097. Stanford University.
- Ožbolt M., Cerovšek T. 2010. Integrirano timsko delo za celostno zasnovo stavb. Gradbeni vestnik, letnik 59, April 2010, p. 82-96.

# Dr. Emilio M. Colón, Eduardo Colón, Puerto Rico

## Tablets Simplify Construction Management

World Council of Civil Engineers

E-mail: [secretariat@wcce.net](mailto:secretariat@wcce.net) / [president@wcce.net](mailto:president@wcce.net)



### ABSTRACT

Tablet computing, mostly in the iPad and Galaxy models are serious and effective tools in many areas of life, but in particular are most effective in the technical fields. Ever since the coming of computers in the forties through large mainframe, computers to the personal computers in the seventies, simple ones in the eighties leading to the laptops and netbooks, the smart phones and tablets have come of age. Although at first, most had limited capabilities, ingenuity has allowed many developments in programming, now better known as Apps. As they increase in memory and computing capacity, with availability of access to hard drives, the Cloud and internet connections, Tablets virtually can achieve a better than a 90 % solution—certainly what engineers and architects need. The moment where the tablet and Building Information Modeling, or BIM meet, it allows collaboration between designer, consultants, contractor, sub contractor, project managers and owner. The BIM platform, by being a 3d interface, allows the creation of elements and objects that have properties and data to be output for either quantification, communication and ultimately understanding of the project, building, structure and subsequent sub system and infrastructure. The BIM application as well as the use of the Tablets as a virtual remote terminal, long battery life, clear screen and ease of use, makes them an ideal field tool.

Linking BIM with other Apps will take the advantages of strong computing to the field, where issues can be quickly resolved. The paper will discuss how these linkages are made.

## PAPER

First, it was using beans or other grains to count. Then came the abacus, which allowed for many centuries even the performance of arithmetic functions. Ever since the coming of computers in the forties through large mainframe, computers to the personal computers in the seventies, simple ones in the eighties with ever developing PDA's, leading to the laptops and netbooks, the smart phones and tablets have come of age (Figure 1). Although at first, most had limited capabilities, ingenuity has allowed many developments in programming, now better known as Apps.

So what does the new version of the Tablet Computer have to offer us today, and is it worth all the hype? Can something like the iPad really bring a new dimension to the CAD / BIM industry and the architect's and engineer's design workflow, from simple 2D drawings to complete virtual experiences?

Many tech enthusiasts believe that the introduction of the first iPad was most certainly a game-changer in the technology landscape, though the release of the iPad 2 brought even more shivers down our spines, by raising the bar yet again. Similar, the newer iPad 3 and other models like the Galaxy (and the continuous introduction of other models) will continue to revolutionize the professions. The updates were especially important for graphic geeks and design professionals alike, with 9 times faster graphics performance and double the CPU, bringing extra power to process complex drawings and 3D environments. And the interconnectivity between PC, laptop, iPhone and iPad tablets has been able to break away from the limiting desk and office (Figure 2).

*"We really believe that the iPad represents an inflection point in the CAD industry... it has phenomenal portability with its very long batter life...and with Multi-touch your simply can't match what it can do with any other computing device."*

(Royal Farros, CEO of IMSI) - via Architosh

This type of multi-touch device can prove beneficial in many fields, but especially in the Architect-Engineer-Construction (AEC) industry; from sketching & annotating drawings, to providing a more interactive user interface for viewing & editing 3D models, playing with different lighting and material options, or just navigating through CG environments.

*"It's kind of like the switch when everyone suddenly had mice.... if you kept building applications just for the keyboard, you would have been equally crazy. The same thing is true now with Multi-touch."*

(Carl Bass, CEO of Autodesk) - via Architosh

Imagine "pinching" & "flicking" through a virtual space or actually walking on site to navigate an augmented reality environment - creating a much more "natural" experience for the architect and client - or even editing LIVE models right from the building site while directly connected with the design team back at the office via the Cloud. The possibilities are mind-blowing, but most certainly not beyond our reach!

## CAD ON THE PAD

While many of the apps here have been developed for Android tablets as well, we will focus on some iPad apps that have been developed for architects, engineers, designers and other professionals in the AEC industry.

Many of us have probably used an iPad at some point as a replacement to our past projects, sharing comments or while showing off a great amount of images and drawings at a meeting or even just at the bar with friends, or impressing someone else, but there's got to be more to it than that, right?



Well, some Apps in the Store have already started to show the power of the iPad in the design and coordinating process, from viewing 3D models with iRhino 3D, SightSpace 3D, or 3DVIA Mobile, drawing & photo-editing with Brushes, Adobe Eazel or Photoshop Express, 2D CAD drawing with SitePAD, FingerCAD HD, Turboviewer, or GraphPad, and even full 3D modeling with Verto Studio 3D, to name a few.

Autodesk has been stealing the show for a while on the iOS front, with Sketchbook Mobile (paint and drawing), 123D Sculpt (quick and easy 3d modeling), Autodesk Design Review (review and annotate DWF models), Buzzsaw Mobile (project document viewer), Bluestreak (real-time messaging and collaboration), Inventor Publisher Mobile Viewer (3D assembly instructions viewer) and especially Autocad WS, which has registered over 2 million users online with around 4 million drawings uploaded.

Some other major companies, however, are finally catching up and joining the front-line with some amazingly innovative apps, such as Graphisoft's BIMx, Abvent's iVisit 3D and Autodesk's Design Review. These apps, being the major innovators, since they combine the resulting project documentation with BIM visualization and result is a file on the go achieving mobility.

## CAD IN THE CLOUD

The "Cloud" seems to be yet another new word buzzing in our ears more and more, and large enterprises such as Apple, Microsoft, Google and Amazon are investing millions of dollars approaching this new technology. It's an innovation on a similar level to jumping from basic 2D & 3D CAD to full blown Building Information Modeling (BIM), fundamentally changing how buildings are designed.

We are not going to get into the intricate details of the Cloud, though it's not such a difficult concept to grasp; most of us have probably used some type of this technology at some point, like Gmail, Google Docs or Dropbox. Going a step further is the concept of Chrome OS or iCloud. Refer to Figure 3.

Essentially it has the ability - with the Tablet Computer as its companion - to reshape AEC workflows and "untether" us from the shackles of the office to design and collaborate freely from wherever we want. No more need to email tons of data with the risk of attachments not reaching its destination or the recipient needing additional information. Entire project could be shared and worked upon with a central file for all to look at. This is all done with little ease and even cheaper effort.

This even breaks the limits of time, as chain work, review and processing can take the workflow around the world and time zones. Messages like, "could you look at this design so we can wrap up the project tomorrow morning?" will become common ways of work.

*"Fundamentally, I see the iPad as a cloud device. Without an Internet connection it is a useful device, but connected to the Web it is a dramatically new way of computing."*

(Sean Flaherty, CEO Nemetschek Vectoworks) - via Architosh

Although mobility might be seen on what program you want, it is also dependent on what you need in the field and results you need to achieve.

## VIEWING

There are a ton of apps for viewing 3D files, such as Bim X, GoBIM, AutoDesk Design Review, iRhino, and SightSpace 3D for Sketchup. Somewhat of a standard around 3D navigation has begun to emerge: pinch to zoom and two-finger orbit. Apps like AutoCAD WS are also adding annotation features.

Advent on industry standard companies have heard and discovered the value of making there programs mobile at an economical rate. PDF has been for a while the most common viewer for available apps. However, in the last year, perhaps more like months, dwg, dxf & dwf viewers have been more accessible.

Yet, there is the three-dimensional wall that allows the enhance accessibility of the tablets graphics that enables better communication efforts. The two main apps are as Graphisoft's BIMx and Autodesk's Design Review. Although, other 3d visualization apps exist, the two main ones that achieve viewing Revit models or Archicad models on tablets are the aforementioned ones.

Visualization on these includes walk-throughs on the model as to experience the space before completion. It allows for tweaks and better understanding of the end result. However, recently the ability to quantify data from the model has been added to these apps. This aspect shall be discussed in detail later on.

## DRAWING

In the drawing space, Sketchbook Mobile has really taken the lead. This thing is everywhere! The experience is really satisfying and even people who do not normally draw can start to immediately feel a sense of mastery. GraphPad provides a more CAD-like experience. Not as satisfying as Sketchbook, but it has dimensions! And its use is simple and without having to research instruction manuals. It truly allows the ingenuity of the architect and engineers do what thy do best.

In most cases, the app connects to a central server by which users may connect and view the files for real time collaboration. Also, the ability to upload the files directly to the tablet also exists. However, for true collaboration exists, we believe that the ability to deposit files for everyone to see, comment and work on should be the real goal in order to take full advantage of this technology.

Other programs are RedStick iCAD, GraphPad, OrthoGraph, etc.

## DIAGRAMMING

Architactile inception: A really cool name and a LOT of features. It fills a gap in the early design workflow. But what about the mobile form factor does this leverage? And really? \$500 for an app? The combination of high cost, rich feature set and minimal advantages to being mobile make this better suited for a desktop or web app.

Although this app, is better suited for Pre-Design or project management, wouldn't we want to better serve clients on the road when visiting the project for the first time. Or wouldn't we want to breakdown the project and execution while running back to the office?

## ANALYSIS

This is another area where there are not yet many useful apps. Two in particular seem promising: Sun Seeker and See Breeze display the current and historical sun and wind data for the location you select (or your current location.) They have a really nice augmented reality view that overlays the sun path or wind direction onto your view using the camera (if available). Both of these demonstrate an integrative approach to the device's features: GPS, gyroscope and camera.

Although visualization apps offer a small glimpse at this, the sun is on a fixed angle and cannot be modified on the app. However, one can hope this is only a matter of time before an app to analyze sun angle, wind directions comes thru.

## MODELING

3D Modeling is a strange beast. One would assume that innovative hardware + 3D = a plethora of great apps. But that has not happened yet? Why? I can take a stab: A tablet is no different than a mouse in terms of interaction. It is still the 2D mapping (screen) to 3D space. Actually, it is worse because although you are “directly” manipulating the object on the screen via touch, your big, fat finger is less precise and your big fat hand blocks about 1/3 of the screen.

### **iPad App Showcase:** BIMx : ArchiCAD BIM Explorer on iPad

One of the highest ranking pages on the blog is an old post from Feb 2010, posing the question if we'll ever see a version of ArchiCAD on iPad, or even more plausibly something similar to Virtual Building Explorer, to provide real-time 3D navigation and enhanced understanding of ArchiCAD models. Well, I'm sure we're all excited by what is probably one of the most anticipated architectural apps for iOS, Graphisoft's BIMx!

Like its Virtual Building Explorer (VBE) predecessor, it's basically a 3D model viewer in an interactive environment with intuitive game-like navigation, but with a few tricks up its sleeve. It allows anyone to view and explore BIM models (exported from ArchiCAD 15 +) without having the actual modeling software. Features are great include the insanely simple Joystick navigation, fly mode, pinching in and out (like when viewing images on iPad) to “zoom” into the model - effectively quickly transporting to that point - and “Gravity-mode” that keeps you on the ground, making it much more realistic in a “first-person shooter”-like way.

Graphisoft's BIM Explorer (BIMx) is the new name for its Virtual Building Explorer application that it launched in 2009 (see the AECbytes Tips and Tricks article on this tool), providing an interactive environment with game-like navigation and allowing anyone to explore full BIM models without having a copy of the original software in which the model was created, i.e. ArchiCAD. BIMx works as a companion product to ArchiCAD, allowing ArchiCAD models to be exported into BIMx as well as saved as self-running executable files that can be shown to clients on a computer (the BIMx desktop application is part of the standard ArchiCAD 15 installation). Graphisoft has extended this capability into a BIMx iPad app that is integrated with a Facebook-enabled online BIMx community, where BIMx models can be posted for others to share. After downloading the free BIMx app from the iTunes Appstore, you can browse through this community site and download any model, which you can then open in the BIMx app for viewing and navigation (see Figure 4).

Of all the model-viewing apps that have been tested so far, the most impressive so far is the BIMx app (Figure 5). The controls to navigate the model were easy and intuitive to use. For example, a joystick that appeared in the viewing window (see Figure 6) allowed you to walk forward, backward, or turn in place. You could fly to any location in the model by tapping on it and then tapping on the icon that appears in that location. As with other iPad apps, pinching the fingers in and out zoomed the model in and out, while panning the model was done by swiping two fingers on the screen. Outside the building, a swipe of one finger allowed you to orbit around the model. All of these navigation techniques were captured clearly and concisely in a set of six slides that could be accessed by touching a Help icon at the top of the window. Other helpful icons included a “Fit in Window” capability and a Settings menu, where you could specify options such as whether you wanted a 2D navigation map to be displayed alongside the 3D model, the type of shading on the model, the navigation speed, and a few others. What I missed, however, was returning to a “Home” view as well the ability to save and open specific views. The BIMx navigation preserves the verticality of the model, given that it is specific to buildings and is not a general purpose model viewer.

### **iVisit 3D : Design Visualization Panorama Exploration**

Abvent's companion app to its highly successful standalone rendering software “Artlantis”, iVisit 3D is more a design visualization tool, rather than a navigation app for 3D models. It's a tool focused towards architects

and design engineers mostly, as after creating them using Artlantis Studio 4, you can export the model with specific rendered panoramas. Available in two versions, Lite and Pro, the former is completely free, but limits the ability to view one panoramic model per day.

As with most iPad viewer apps, iVisit 3D allows sample models to be downloaded directly from within the app, letting you get stuck in quickly to explore some panoramas in full rendered glory. One of the favorite features is definitely the option to physically move the iPad to rotate through the panoramas.

iVisit 3D is more of a design visualization tool than a 3D model navigation app. It is developed by Abvent, editor and publisher of the popular rendering application, Artlantis. Targeted especially for architects and designers, iVisit 3D allows them to present panoramas of their projects online using an iPad. The actual creation of the panoramic views is done using Artlantis Studio 4; thus, iVisit3D is more of a companion app to Artlantis. The iVisit 3D App is available in two versions, Lite and Pro. The Lite version is free, but is limited to the selection of one panoramic view per day. For those who just want to explore the app without having created models in Artlantis to pull into iVisit 3D, the app lets you download sample models and see how they work. One of these is shown in Figure 8. As you can see, the quality of the rendering is very good, and because it is a panorama, you can rotate the view in order to see it from all sides. You can also click on arrowed markers in the 3D views to jump to a different view, if required, or access the markers by opening a floor plan view. A nice feature in iVisit 3D is the additional option to rotate though the panorama by physically moving the iPad around.

#### Autodesk Cloud, Design Review App & Autocad WS

In order to take advantage of cloud computing, Autodesk formally unveiled its cloud strategy after numerous references to the infinite computing power of the cloud. Essentially, what Autodesk now provides is free cloud storage for drawings, models, and other documents for its users, which can be used to access these files from any platform and which can also be used for sharing and collaboration. All users can have 1GB of cloud storage space, while Subscription customers receive 3GB of cloud storage per seat on Subscription. To access the Autodesk cloud, you simply need an Autodesk ID. Once you are logged in to your cloud storage space, you can upload files to it and share them with others. I uploaded some sample DWF files from my computer to it (see Figure 9), which I could then access with the Design Review app on my iPad.

Since the Design Review app on the iPad has launched, you can open up a sample DWF document or recent documents that you may have accessed, both of which are stored locally so that they can be viewed even when the iPad is offline. There is also the option to sign into the Autodesk cloud, if the iPad is connected to the Internet, and access the documents that you have uploaded, as shown in Figure 10. Once you have selected a document to view, there is a simple set of controls that can be used to navigate the document. Recall that these can be 3D models, 2D drawings, or any other document, such as an image, a Word document, an Excel file, and so on. The sample DWF file shown in Figure 10 has seven sheets, including the 3D model, a 3D sectional perspective, two floor plans, and three rendered views saved as image files. 3D models can be orbited to see them from different sides and zoomed to explore details or interiors. However, the orbiting does not maintain the verticality of the building since Design Review (and the DWF format) is not specific to building design but can also be used for MCAD models.

In general, model navigation is much better in Graphisoft's BIMx app, which has a lot more navigation controls, the option to fly through a building, as well as preserve the verticality of the building. But what Design Review has that BIMx currently does not is a "Home" button that takes you back immediately to the starting view in case you get "lost" while navigating; the option to save multiple views for a model or 2D drawing in the DWF file, which are then available in the mobile version of Design Review and can be used for quick navigation; and the option to select an element and see its properties, as shown in Figure 6. This capability is going to be very critical for a BIM model, since it has so much information captured in it for

every element, which can now be very easily accessed when required. Other capabilities of Design Review for 2D drawings and image files include the ability to add markups using a basic toolset, and the ability to access the different layers for a drawing, if this has been enabled in the DWF file.

Now, with Autocad WS, we go to CAD drawings on the go. It started small by creating, viewing & sharing drawings on the web, advancing to now being able to sync between computers, the web and mobile devices. Some of the best features are the ability to open DWG and DXF files, add text notes and revision clouds, accurately drawing shapes and measuring distances, and especially offline access to your files. But don't worry, it automatically synchronizes files when internet connections is acquired. It also requires the user to create an account with Autodesk and load files to a server. Another feature is the export tool. On Autocad WS, the user may export to a previous version of Autocad and email it for sharing. This helps when sharing files with users that may not be up-to-date on technology.

### SightSpace 3D: Augmented Reality Sketchup

Augmented Reality is one of the newest innovations in tech; it's essentially the superimposition of graphics, audio and other sense enhancements through a display onto the real world, thus "enhancing" our reality. One of the more impressive apps to hit the App Store this year is SightSpace 3D, a great app for architects and urban planners allowing you not only to view your SketchUp models on iPad, but also to see them directly superimposed on the real world through the iPad 2 camera in real time! Just point the iPad to face the proposed site and see the 3D model come to life directly on the land, while adapting to your motion around the real-world site.

*"Existing environments, like landscapes and trees, can be easily incorporated into the view, in real time. SightSpace 3D can also be utilized by interior designers to view furniture, art, flooring, and other components long before building begins."*

- Dr. Errin T. Weller (President of Limitless Computing Inc.)

### RedStick iCAD

Redstick SiteCAD. Start your BIM process on site, collect data, take your measurements and export an IFC model to ArchiCAD, Revit and any IFC compliant software. It is a simple and non-expensive answer to carrying your portable computer and achieving quick measured sketches for later working at the office.

### INCEPTION FROM ARCHITACTILE

The Inception app from Architactile is very different from the other apps so far. To start with, any brand-name vendor in the AEC field, who is developing it as a companion app for its main desktop applications, and can therefore offer it for free to boost the sales of its existing applications, does not develop it. Also, it is not an app for any kind of "post-design" work such as visualization, viewing models and drawings, project management, or field work for construction, as most apps for AEC tend to be—with the premise that the building design has been done using a traditional application on a regular computer. In contrast, Inception is an app that is custom-built for the iPad and is available only on the iPad. Designed specifically for architects, it addresses the pre-design phase, allowing them to capture all the requirements of the project in the course of early project meetings with their clients, which can then be captured in a PDF document and sent to the client for review. Thus, it is intended to be a serious business tool, and is therefore not free like the other apps. Let's take a look at what it does before getting into how it is priced.

Unlike the desktop application, Trelligence Affinity, that includes capabilities for space planning, programming, and schematic design, and bi-directionally links with BIM applications like Revit Architecture and ArchiCAD (see the AECbytes feature article on Affinity), Inception is designed to be even more early-

stage, preferably used during the earliest meetings the architect has with the client, where he or she can pull out their iPad and use it to capture the core program requirements of the project. It lets you specify where the project is located, thereby impacting its cost; define the different spaces or use groups in the project, and their individual occupancy, density, quality (cost/sq.ft.), and unassigned area to calculate their gross area and total cost; create a bubble diagram and adjacency matrix of the spaces or use groups; do a cost estimate analysis of the entire project; and create an early-stage Gantt chart showing a tentative project schedule. Several of these capabilities for a sample project are captured in the following screenshots.

As mentioned earlier, Inception also includes the capability to capture all of this data and calculations into a single PDF document that can then be sent to the client for review. An architect might develop such a document after the first or second meeting with a client, assuming that a basic program has been established. It takes about an hour to develop this document in Inception. One of the benefits of taking a document like this to the client very early in the process is that it helps the client (and the architect) to stay focused on space and budget. By helping the client to understand the direct relationship between space and budget, the client becomes an active participant in the effort to maintain a feasible scope. The result can be a shorter time between first contact and a signed design contract, a better defined scope for the project architect, and much more realistic client expectations. In cases where the project simply isn't feasible, the use of Inception helps to minimize wasted time.

Not surprisingly, then, Inception is not a free app, but costs \$499.00, making it one of the most expensive apps in the iTunes store. When compared with the price of regular desktop applications, this seems very reasonable, given its business proposition. The question is whether architects and engineers are using the iPad, or other Tablets, as a serious business tool to justify purchasing a relatively high-priced app in an iPad universe where most apps are free. Also, Inception currently does have one major limitation, which is that it is not possible to export a project that others can then import on their iPads. It can export CSV files capturing project data that can be read by an application like Affinity for more detailed programming and space planning on the project, but it would be good to also have the option of sharing project data with others having the Inception app on their iPads. Perhaps, Apple's recently announced iCloud initiative would enable Architactile to build this feature into Inception more easily.

## CONCLUSIONS

There is little doubt that the way we do work is changing, and much more changes are coming at warp speed. We need to ensure that the Construction Industry fully takes advantages of these new tools and their Apps. Only imagination and ingenuity may be the limiting factors, that's what architecture and engineering are all about. Well, maybe a Wi-Fi access on the road will help- but even those days and places when Wi-Fi is not available are rapidly disappearing! Mobile internet access is rapidly spreading worldwide, and the connection speeds are already adequate, even more in the near future.

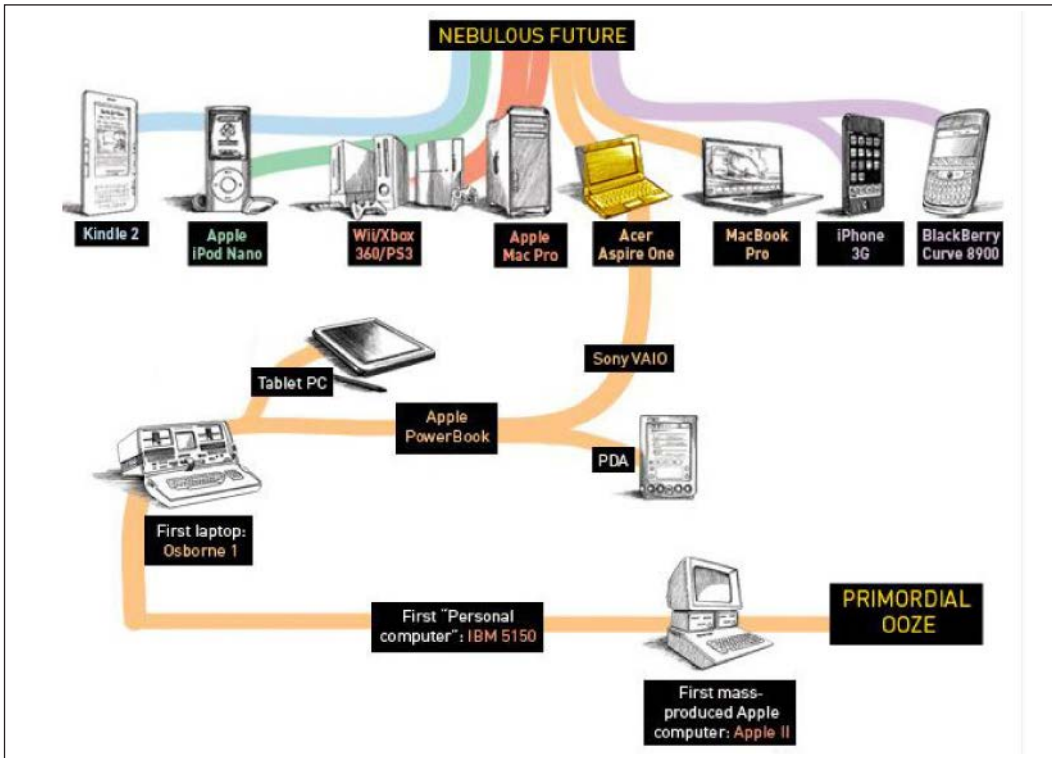

Figure 1 Technology development



Figure 2 Sample Applications relationships



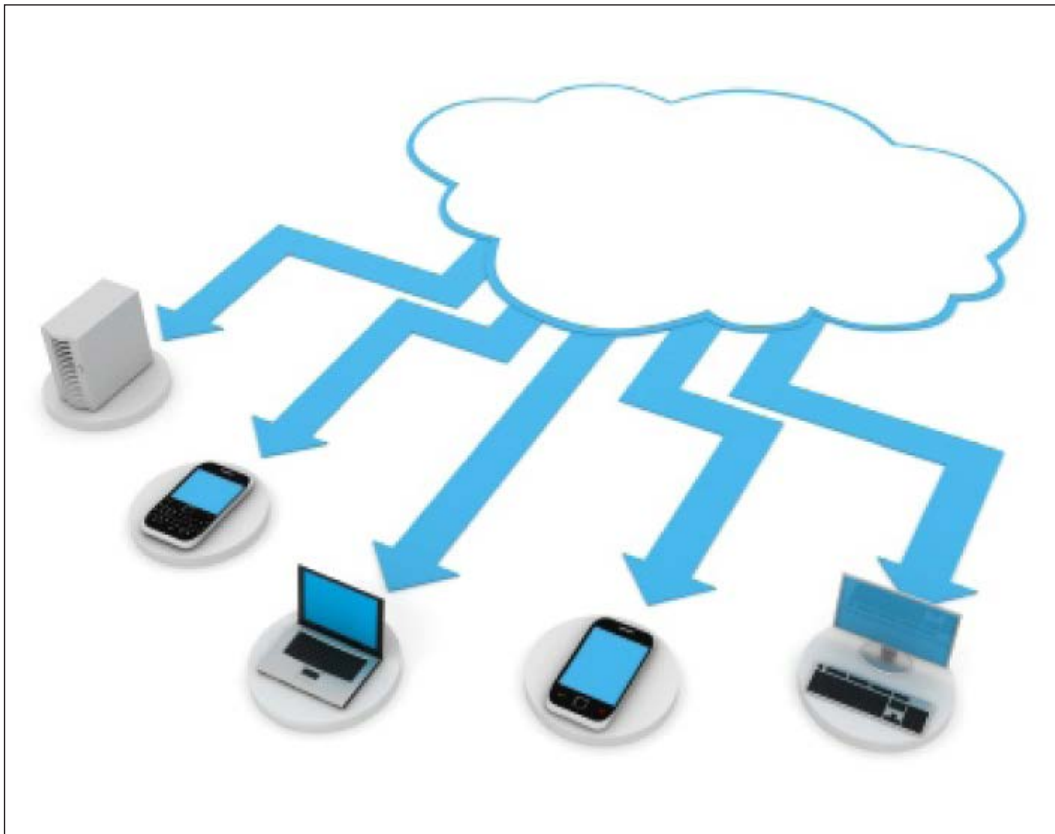

Figure 3 Sharing through the Cloud





Figure 4 BIMx Interrelationships



Figure 5 Design Review viewing windows



Figure 6 BIMx viewing windows



Figure 7

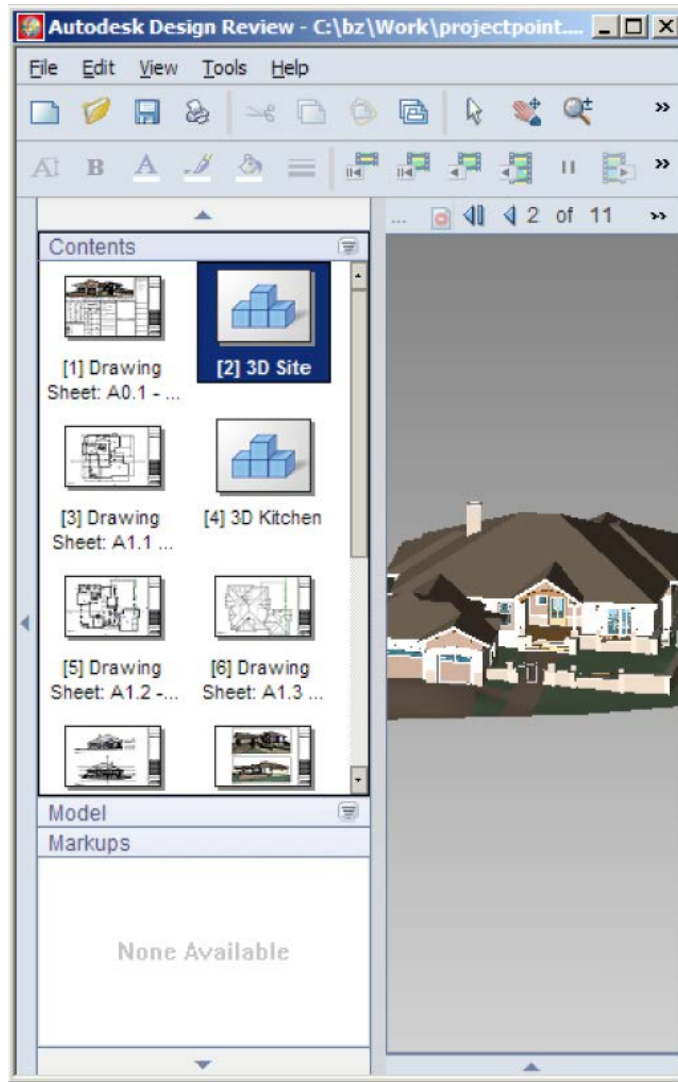

Figure 9 Sample DWF file

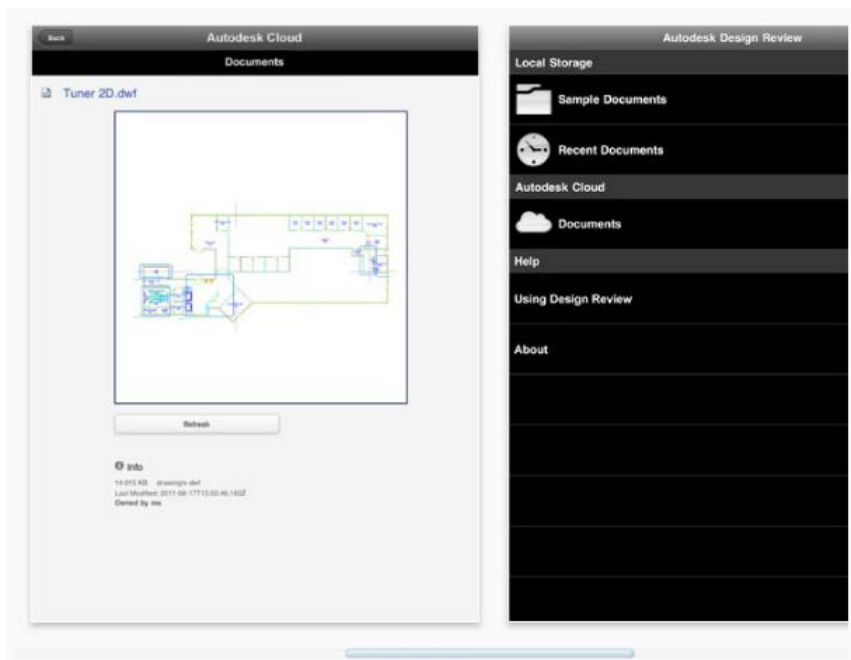

Figure 10 Sample Plan View

# Albert Otto, Nigeria



189

ALBERT OTTO

## Sustainable Construction: Towards a Paradigm Shift in the Built Development Approach

Fugro Nigeria Limited

E-mail: [cedarmarble@yahoo.com](mailto:cedarmarble@yahoo.com)

### ABSTRACT

The paper advocates a shift from modern construction approach to sustainable construction by contractors, ministries and departments of works, through full application of sustainable development principles in the operation of construction projects. It argues that without an understanding of what a sustainable condition is, it is impossible to evaluate the relationship between energy efficiency and inefficiency, compliance and deviation. Principles of sustainable construction are suggested, developed and categorized into four “pillars” – economic, social, environmental and technical pillars. Further, environmental aspects of some construction projects are identified; illustration of the need to minimize capital energy use through a case study is given. The AFRICAN DEED (African Demonstration of Economic and Environmental Design) method is proposed which involves the adoption of some metrics for monitoring and evaluating compliance, application of the indicators herein first suggested, as well as life cycle assessment and Energy (Embodied Energy) Sustainability Index earlier suggested by M. T. Brown and S. Ulgiati – all as sustainability indices proposed for management of construction projects in Africa.

## INTRODUCTION

This paper has its origin, began a couple of years back during my previous service with a Ukrainian-Nigerian construction company, in the examination of the pattern in which the modern construction industry impact on the environment and human health. It argues that a shift should occur in construction thinking and action in order to protect the precious natural resources and the regenerative capacity of the world's ecosystems. Sustainable construction is an opportunity to demonstrate a number of best practices and create jobs that mitigate potential impacts and promote the well-being of humanity and the Earth. However, without an understanding of what a sustainable state is, it is impossible to evaluate the degree of energy efficiency of a proposed building or infrastructure, identify sustainable materials and processes, and judge between compliance and deviation. Sustainable construction takes into account the material, the method, and the manpower. An appraisal of energy efficiency, environmental and human health protection in construction is presented using the efforts of the Gulf Free Zone on the Snake Island Integrated Free Zone Project at Apapa Port in Lagos, Nigeria.

Every new construction, by express analogy, is a degradation of the natural environment, since it completely displaces the biomass of a specified portion of the natural ecosystem and covers that green space with an inanimate infrastructure or building. The construction industry is a sector that has a marked high tendency of having effect on sustenance from factors such as size, location, land use, energy demand, materials procurement and utilization, mechanization, waste discharge, encroachment, pollution, manpower redundancy etc. Sustainable development does not focus solely on environmental protection, but on the three "interdependent and mutually, reinforcing pillars" which are economic development, social development and environmental protection, and perhaps on the emerging fourth pillar being cultural diversity which the Universal Declaration on Cultural Diversity (UNESCO, 2001) elaborated.

## AIMS, SIGNIFICANCE AND STRUCTURE OF THE PAPER

The main aims of this essay therefore are to identify and evaluate specific techniques that could be utilized in the assurance, control and management of sustainability in the construction industry, as well as recommend and suggest some relevant metrics and indices for monitoring and evaluating compliance. These important considerations are missing from the current engineering codes and standards applicable in Nigeria, and therefore need to be reviewed in order to integrate these concerns as components of policies for achieving sustainability in every construction operation. Although, there are various indicators and methodologies for monitoring sustainability. However, in this essay, five indicators are adopted.

The question may be: How can activities, manpower and material requirements be best manipulated to shift towards more sustainable form of construction? These concerns, which are at the heart of contemporary concern with sustainable development, formed the basis for this discourse.

## STATEMENT OF THE PROBLEM

Sub-Section 4.15 of the National Policy on Environment of the Federal Republic of Nigeria which is concerned with Construction noted as follows:

Environmental concerns should, therefore, focus on the anticipated impacts of the following major aspects:

- The sustainable procurement of construction materials;
- The adoption of processes/stages of construction that are environmental friendly;
- The effect of the completed structure(s) and the contained utility on the environment.

Further, that sub-section 4.15 (a – l) of the Policy provides the strategies for ensuring development in the construction sub-sector of the economy, encompassing the themes of EIA, remediation, audits, quality standards, by-laws, impacts, health and safety of workers, aesthetics on site, protection of farmlands, etc.

From the forgoing, it is obvious that the Policy set a framework for action and adopted sustainable development as a principle for construction practice.

Contrarily, the Nigerian construction industry as it is today seems to be quality – centred and lacked sustainability. A quick look at the current paths of construction will justify this seemingly extravagant claim to lack of sustainability.

However, this study has identified some of the current key problems resulting from unethical practice and deviance of the Environmental Policy, and summarized them in the following statements.

- *Negligence of Environmental Impact Assessments (EIA) protocol and impact mitigation guidelines is common.*
- *Damage of economic crops and unsolicited farmland acquisition spread crises and panic.*
- *There are no instruments built into the project blue print for evaluating environmental deterioration and enforcing post-construction remediation.*
- *Non-enforcement of by-laws on minimizing material procurement, transport and utilization impacts on the environment, especially with regard to noise, dust, spent oil, fuel, noxious gas emissions etc; leaves a big gap between current practice and standard.*
- *The ratio of non-renewable energy and natural resources to renewable options, in large-scale construction, is greatly non proportionate.*
- *Dumping of wastes and spoils on private land and damage of existing facilities prompt petition to the distraction of project parties.*
- *Negligence of the right of indigenous people and their communities to participate fully in development projects on their land persists.*
- *High machinery density renders available manpower redundant and increases unemployment rate and Co<sub>2</sub> (greenhouse gas) emission.*
- *Illegal and unethical dredging which portends damage to indigenous fishing and swamp farming occupations and the coastal environment in general thrives.*

## THE CONSTRUCTION INDUSTRY: AN OVERVIEW

The modern construction industry embraces the erection of buildings and a wide range of civil engineering projects such as highways, bridges, railways, dams, drainage channels, canals, airports, wharfs, jetties, shore protections, retaining walls, reservoirs, tunnels spillways, water supply systems, landfills, industrial complex, energy and power generating stations platforms, etc.

These diverse projects vary in size, complexity, duration, technology, location and finance. A typical infrastructure construction will require all or some of these raw and manufactured materials: sand, cement, laterite (clay), steel, aggregate (granite, basalt, etc) bitumen, timbers, etc. In Nigeria, and of course most African countries, the building of high quality would require the aforementioned and a finishing with glass, wood, marble, aluminum, mineral fibre, gypsum, plastics, chrome, etc, which are imported, and hence raise cost. These materials come from the Earth at a cost end-user never know, and require energy resources to run various machines during their installation.

At present, 75 per cent of cement used for Nigerian Construction is imported, while only 25 per cent is being provided by existing seven plants. Yet Nigeria's construction policy of 1994 was targeted at the following: *the use of indigenous building materials and industries, the use of energy efficient designs, and use of labour intensive construction and maintenance techniques for the generation of employment.* In 2005, the report at the Investment Conference in Construction and Civil Engineering put Nigeria's housing deficit at

over 14 million units, and predicted an expansion of the construction sector as 10 per cent per year.<sup>[1]</sup> It added that construction shares 6% of total GDP with textile and others.<sup>[2]</sup> Indeed its contribution to the Nigerian GDP and employment is very low as yet, owing to high density of foreign expatriates. Importations of construction materials raise the Environmental Loading Ratio (ELR) and hence reduce the Environmental Sustainability Index (ESI).

In our construction sites, the great number of trucks, bulldozers, excavators, cranes, plants and others are run by carbon energy sources – oil (diesel, petrol, kerosene) and gas. And when these fossil fuels are burned, they emit CO<sub>2</sub> (a greenhouse gas) into the atmosphere. Regrettably, no body seems too bothered about the issue of heavy duty machines and plants discarded by developed countries on account of unacceptable emissions of large clouds of black smoke, CO<sub>2</sub> and other greenhouse gases (GHG). Open-pit mining of clay degrades the environment and leaves scars that pose hazards to life, and spread crises. In most riverine communities of the Niger Delta, unethical dredging activities persist, destruction of rain forests and fishing creeks.<sup>[3]</sup> And in some cases, they are carried out around highway and railway bridges.

In Nigeria, however, there are institutional mechanisms for engineering construction regulation. For example, the Council for the Regulation of Engineering in Nigeria (COREN) monitor and control compliance with regulatory standards; and the National Environmental Standards Regulation Enforcement Agency (NESREA) is empowered to enforce standard and compliance with laws and policies on environmental issues, though of course rarely fully achieved. The standard conditions of contract and general specifications for work of civil engineering construction are those prepared by the Federal Ministry of Works and Housing.

## SUSTAINABILITY: A NEW CRITERIA FOR CONSTRUCTION

Sustainable development, since the Brundtland Commission, has been explored to encompass the 'triple bottom lines' of environmental protection, economic development and social equity.<sup>[4]</sup> Construction is an element of development, hence sustainability in construction cannot be ignored; it has to be managed. Sustainability in construction will satisfy client's needs and expectation, respect cultural and social values, and comply with government policies and regulations on engineering and environmental standards. Therefore, we begin to lay the groundwork for a major shift in our construction strategy. And one useful way of illustrating the need for the new approach is through life-cycle analysis of a construction projects, from the preliminaries through materials sourcing and full scale work to clean up and usage.

As we begin the discussion of the role of construction in achieving a sustainable society, it is necessary to define the meaning of **sustainable construction** to serve the purpose of a working definition and probably serve in future discourse.

**Sustainable construction** is construction technology practice concerned with creating infrastructures through a systematic approach that employs processes, energy, and materials which account for long-term environmental protection, as well as solutions to the economic or social needs of end-users.

Therefore, the design and construction of infrastructures should be environmentally friendly and consider other aspects of human life affecting sustenance. According to Brenda and Robert Vale, 'Sustainability implies that there should be no irreversible pollution, no reliance on finite resources and a stable population'.<sup>[5]</sup> In 1994, the Conseil International du Batiment (CIB) defined the goal of sustainable construction as: "creating and operating a healthy built environment based on resources efficiency and ecological design"<sup>[6]</sup>.

Well aware of this fact, an attempt is made to adopt two existing indicators, while three new ones are formulated suggested and with aim that they will be practical to enable a demonstration of their relevance



in Nigeria and other West African Countries through what I call AFRICAN DEED (African Demonstration of Economic and Environmental Design) so, it might be said and seen that, in DEED, the African Union is desirous of institutionalizing an environmentally sustainable construction industry. Other international mechanisms for regulating embodied energy worthy of note are the SB Tool, UK Code for Sustainable Homes and USA LEED.<sup>[7]</sup>

## THE PRINCIPLES OF SUSTAINABLE CONSTRUCTION

In the ten principles of sustainable construction articulated below, I set out what I believe would ideally inform decision making process, and control material and energy use, pollution, mechanization, hazards to health, life and property, and also contribute all through the entire life cycle of the building or infrastructure. I also call these ***“The ten commandments of sustainable construction”***.

Table 1

TEN PRINCIPLES OF SUSTAINABLE CONSTRUCTION	
1.	Satisfy client’s needs and meet specified quality standards.
2.	Maximize the use of renewable or reusable resources, materials and products.
3.	Observe zero discharge of slurry, fuel oil, chemicals and particulate material into the environment.
4.	Allow Site Remediation Retention (SRR) which is payable upon proof of compliance.
5.	Provide site waste management and material mining site restoration plan.
6.	Maximize the percentage of construction waste and salvaged materials from demolition being recycled.
7.	Apply life-cycle costing of project which indicates that long-term costs and benefits outweigh short-term costs and benefits.
8.	Maintain standard ratio in cost between machinery and unskilled community manpower employed into the project category involved.
9.	Comply with standard limit of embodied energy of materials permissible by statutes.
10.	Conduct construction activities in a manner that is safe to health, life and property.

The above principles may be divided into four pillars: Technical, environmental, economic and social. Principles number 1 is in terms of technical consideration; numbers 2 to 6 are based on environmental concerns, numbers 7 to 9 are in terms of economic sustainability; whereas 10 consider social issues of life and tort.

The CIB made a good attempt at doing this. However, the CIB had short comings in representation, in that there was no mention of the natural energy resources of wind (air) which powers wind turbines on wind farms, for example the 5mw wind turbine 28km off the coast of Belgium, solar and other renewable energy sources applicable in construction projects. If solar energy could be alternative resource for powering a water plant for a project daily water needs, then, it should have been necessary to consider renewable energy sources. And there was omission of ‘recycling’, which is a major issue after deconstruction on the embodied energy scale.<sup>[8]</sup> Their propositions covered the following six aspects:

- Land use and rebuilding
- Use of renewable resources and materials options
- Technique (process)
- Information and communication Technology (ICT)
- Cultural issues/Community input
- Community labour

Obviously, there are more to the principles of sustainable construction than the above.

## ENVIRONMENT ASPECTS OF CONSTRUCTION

In this section, an attempt is made to identify some major elements of construction projects that interact with the environment. However, the environmental aspects of highway and bridge projects are considered. The others -- such as airport, dam, wharf, etc -- are ignored, mainly for reasons of space. A summary of major environmental aspects of highway and bridge works are presented, for purpose of demonstration, in Table 3. Those that are not considered here may be discerned by considering emission to air; release to water; contamination of land; natural resources depletion; capital energy use; waste generation and discharge; land use and damage; local cultural issues.

Table 2

PROJECT	ENVIRONMENTAL ASPECT	ENVIRONMENTAL REASON
1. Highway	Site clearance (deforestation)	<ul style="list-style-type: none"> <li>• Heavy duty machinery emit CO<sub>2</sub></li> <li>• Noise and vibration</li> <li>• Machine exceeds free work area to damage green field, farm crops, trees or existing facilities.</li> </ul>
	Excavation (waste generation)	<ul style="list-style-type: none"> <li>• Unsuitable material spoils are dumped on neighbouring crops, green field, or private property space pending when construction is completed.</li> <li>• Noise and vibration</li> </ul>
	Earthworks (mineral mining/haulage)	<ul style="list-style-type: none"> <li>• Open-pit mining of laterite (Clay) leave deep scars (borrow pit) that become pool of water and zone of hazard to animals and breeding places for mosquitoes.</li> <li>• Noise and vibration</li> <li>• Damage of prime farmlands</li> <li>• Wind dispersal of fine material in transit</li> </ul>
	Concrete works (Drain, Median, etc)	<ul style="list-style-type: none"> <li>• Use of finite minerals: granite, basalt or limestone</li> <li>• Heat of hydration of concrete affect vegetation, microbes, etc.</li> </ul>
	Asphalt Pavement (chemical product)	<ul style="list-style-type: none"> <li>• Toxic effluents containing metal ions, SO<sub>2</sub>, NO<sub>x</sub>, CO<sub>2</sub>, methane, during production.</li> <li>• Waste pillage due to congealing of asphalt.</li> </ul>
2. Bridge	Foundation work bridge or (driving of piles)	<ul style="list-style-type: none"> <li>• Noise pollution and vibration</li> <li>• Damage to aquatic organisms</li> </ul>
	Concrete works (piers, abutments, beams, slabs) etc.	<ul style="list-style-type: none"> <li>• Use of finite minerals e.g granite, limestone</li> </ul>
		<ul style="list-style-type: none"> <li>• Heat of hydration of concrete reach aquatic organisms etc.</li> </ul>
	Sandfilling of abutment	<ul style="list-style-type: none"> <li>• Failure of formwork and concrete contaminate water</li> <li>• Dredging might cause shore slope failure.</li> </ul>

## CONSTRUCTION SUSTAINABILITY METRICS AND INDICES

Supervising engineers, architects and project managers need adequate knowledge of sustainable materials and processes to control and, where necessary, question the work of site engineers or agents and technical

support workers. Following the 1987 World Commission on Environment and Development, different organisations have, through joint initiatives, tried to measure and monitor the proximity to sustainability by constructing environmental sustainability indices and implementing them. ). Ravi Jain (2005) argued that, “The ability to analyze different alternatives or to assess progress towards sustainability will then depend on establishing measurable entities or metrics used for sustainability.”

This section is intended to adopt and formulate some construction sustainability metrics and indices. There are different methodologies and scales used to calculate Environmental Sustainability Index (ESI). However, there may be issues such as international consensus on the correctness of data scales and methodologies which is pending at the moment and difference in opinions and advice from one source or the other still persist. The suggestions here is a first step in seeking to measure and monitor sustainability in the Nigerian construction industry and elsewhere in Africa. Five indicators are adopted here, with the last three being devised for the very first time.

1. Energy Sustainability Index (ESI)
2. Life Cycle Assessment (LCA)
3. Containment Line Deviation (CLD)
4. Material Recycled Coefficient (MRC) and Otto Recycled Tonnage (ORT)
5. Work Mechanization Limit (WML)

### 1. ENERGY SUSTAINABILITY INDEX (ESI)

Minimizing energy cost in terms of embodied and operational use and emissions are the purpose of this indicator. In 1997, ecologists M. T. Brown and S. Ulgiati published their formulation of a quantitative Sustainability Index (S.I) as a ratio of the Energy (spelled with an “m” ie “embodied energy” not simply “energy”) Yield Ratio to the Environmental Loading Ratio (ELR).<sup>[9]</sup>

$$\text{Energy Sustainability Index} = \frac{\text{Energy Yield Ratio}}{\text{Environmental Loading Ratio}} = \frac{\text{EYR}}{\text{ELR}} \dots\dots\dots (1a)$$

Embodied energy is defined as the commercial energy (fossil fuels, nuclear, etc) that was used in the work to make any product, bring it to market, and dispose it. Thus, embodied energy is an accounting methodology which aims to quantify the sum total of the capital energy use over an entire product lifecycle, which (in the case of construction) includes raw material extraction, transport, manufacture, assemble, installation, demolition or destruction, segregation and disposal.

Energy Yield Ratio (EYR) is the energy released (used up) per unit energy invested. The ratio is a measure of how an investment enables a process to exploit local resources in order to further contribute to the economy.

$$\text{Energy Yield Ratio, EYR} = \frac{\text{Energy Released}}{\text{Total Energy Invested}} \dots\dots\dots (1b)$$

Environmental Loading Ratio (ELR) is the ratio of the non-renewable and imported energy use to renewable energy use. It is an indicator of the process of transformation of the environment

$$\text{Environmental Loading Ratio, ELR} = \frac{\text{Non-renewable and Imported Energy Use}}{\text{Renewable Energy Use}} \dots\dots\dots (1c)$$

Typical embodied energy units used are MJ/Kg (megajoules of energy needed to make a kilogram of product), tCO2 (tones of carbon dioxide created by the energy needed to make a kilogram of product). Converting MJ to tCO2 is not simple and direct, since different types of energy (oil, wind, solar, nuclear and so on) emit different amount of carbon dioxide.<sup>[15]</sup> Therefore, the actual amount of carbon dioxide emitted when a product is made will be dependent on the type of energy used in the manufacturing process. For a sub-region such as West Africa with a tradition of powering plants and machines with petroleum energy,

the calibration of scale first would undoubtedly be based on the petroleum or oil energy, and probably the coal and solar scale.

The International Energy Agency forecast that between 2004 and 2030 global primary energy demand will rise by 53%, leading to 55% increase in global carbon dioxide emission related to energy.<sup>[10]</sup> Yet oil supplies are predicted to last another 40 years and some experts opined 30 years. By the 1990s emission rate the CO<sub>2</sub> content of the atmosphere was estimated at roughly 700 billion tones, and is said to be increasing annually by about 6 billion tones.<sup>[11]</sup> The National Energy Foundation which has its mission as “promoting the better use and supply of energy to counter climate change”, developed a simple carbon calculator for use by UK organisations based upon the recommended conversion factors provide by Defra as part of its Environmental Reporting Guidelines.<sup>[12]</sup> A joint initiative of this kind would consider compiling lists of embodied energy and carbon material database, construct different seals to relate embodied energy in MJ/K to CO<sub>2</sub> (tones of carbon dioxide created by the energy needed to make a kilogram of pro duct).<sup>[13]</sup>

## 2. LIFE CYCLE ASSESSMENT

This involves the analysis of the environmental performance of manufactured building or construction products and services through all stages of their life cycle: extracting raw materials, use, re-use, maintenance, recycling, and final disposal. It aims to be practical on the basis of present and long-term cost, human safety, environmental quality and social benefits. The life time of buildings and public infrastructures ranges from 50 to 100 years, occasional maintenance work notwithstanding, so their effects on the environment is a long and continuing issue to consider.

## 3. CONTAINMENT LINE DEVIATION

In our construction sites, it is common for heavy duty machines clearing or handling unsuitable material spoil to encroach reserved green space, private property or existing infrastructures. However, this trend can be put to check by establishing a containment line beyond which construction activities must not be carried out. Thus, there is need to create standard institutional database, for example, a permissible distance of rural road/ highway construction outline from surrounding property, or permissible radius from a lake, spring, etc. This would utilize the environmental drawings as tools for its measurement.

## ENVIRONMENTAL DRAWINGS

A civil infrastructure sometimes involves a marine environment which may be affected by modification, and the effort is in keeping the environment as pristine as possible. At times an environmental design may consider improving the aesthetic and functional qualities of the physical environment through parks, fountains, artificial lakes, etc. So here we cannot limit environmental design to green drawing alone but we talk of the biophysical. Two drawings are being considered: sheet A is the Pre-construction Environmental Drawing, while sheet B is the Proposed Environmental Drawing.

### A. PRE-CONSTRUCTION ENVIRONMENTAL DRAWING

This drawing should show the project location verged red, with block plans to identify outlines of facilities in relation to biophysical features, and must show details of biophysical baseline conditions of the environment, property boundaries, survey numbers or chainages and offset distances. It would serve the purpose of a reference sheet for assessing degree of deviation from containment line. Containment Line Deviation is a technique primarily required by the sustainable construction engineer or representative in order to ascertain:

- (1) extent of encroachment to neighbouring private property or public facility by a contractor.
- (2) area or amount of vegetation cover (green space) damage. It will consider arbitrary loss of green (biomass) due to negligence, and will assume more importance in built-up areas with green field and trees.

## B. PROPOSED ENVIRONMENTAL DRAWING

This drawing is a combination of baseline biophysical features, and green cover to come which are aimed at improving the aesthetic, biophysical and functional qualities of the surroundings in which the facility is located

### CONTAINMENT LINE DEVIATION (CLD) GRAPH

The methodology used in containment line deviation involves the plotting of containment line deviation graph of any section of a road, building, or other project site, and drawing the specified Containment Line which I coined as **conline**. This is a plot of the Actual Work Distance (AWD) against the Chainage (to the nearest metre). Choosing an interval of the Chainage would depend on the frequency of the encroachment. The construction of the graph will be preceded by a table of Chainage, Actual Work Distance (AWD), Containment Line Deviation (CLD), and the Permissible Work Distance (PWD) ie the specified containment line distance from drainage line or foot of embankment.

The CLD is calculated as the difference between Actual Work Distance and Permissible Work Distance (constant). That is:  $CLD = AWD - PWD$ . In summary, Containment Line Deviation, as an indicator, measures the mean containment line deviation (in metre) and the area, (in m<sup>2</sup>) or biomass (Kg) of vegetation cover (organic matter) destroyed, through the calculation of area, enclosed by the graph and the specified **conline** (CL). A chainage interval of 10m or 20m may be chosen.

For purposes of demonstrating the application of the technique, the measurements are outlined in the schedule below (Table 2). The data in the table are assumptive for the purposes of demonstration.

Table 3

Chainage	Actual Work Distance (AWD)m	Permissible Work Distance (PWD)m	Containment Line Deviation (D)m
0 + 000	5	5	0
0 + 010	6	5	1
0 + 020	7	5	2
0 + 030	5	5	0
0 + 040	8	5	0
0 + 050	8	5	3
0 + 060	8	5	3
0 + 070	7	5	3
0 + 080	7	5	2
0 + 090	7	5	2
0 + 100	7	5	2

(i) Mean Containment Line Deviation

$$D = \frac{\sum \text{Distance of damaged green}}{l} = \frac{\sum D}{l} = \frac{0.11 + 2.0 + 0.13 + 1.3 + 1.2 + 2.2}{11} = 1.64\text{m}$$

(2) Area enclosed by the containment line deviation graph

$$= \text{Area of triangle CAB} + \text{Area of trapezium DEFG} + \text{Area of triangle HIJK} = 135\text{m}^2.$$

$$\text{Area of triangle CAB} + \text{Area of trapezium DEFG} + \text{Area of triangle HIJK} = 135\text{m}^2.$$

### Containment Line Deviation Graph

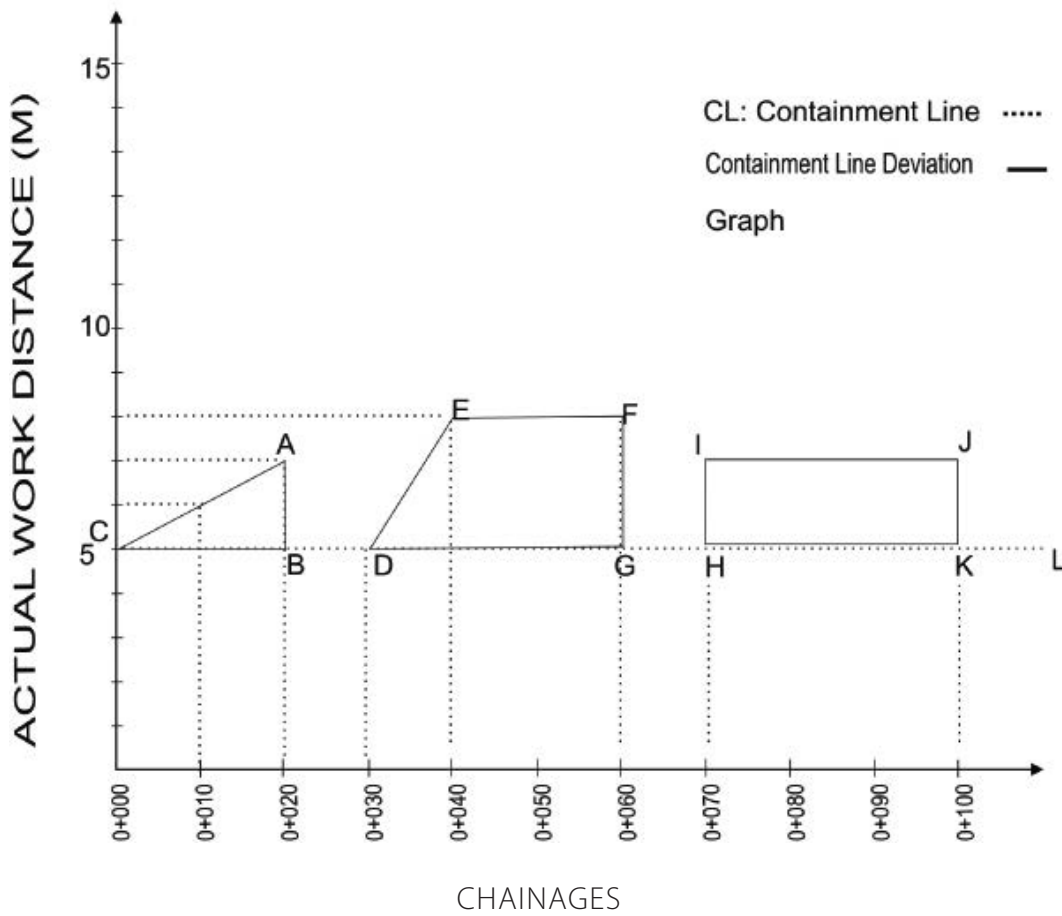

NOTE:

The computation of the lost biomass is a specialist and more discrete evaluation that requires laboratory analysis. To compute biomass, multiply total area of lost green by mass of all biological elements per unit area of the field.

In any case, the graph is more likely to have a zig-zag form depending upon the frequency of negligence of the operation personnel (fig. 2)

#### 4. MATERIAL RECYCLED COEFFICIENT (MRC) AND TONNE RECYCLED TONNAGE (ORT)

The material recycled coefficient is the ratio of amount (by mass) of materials recycled or reused to the total material spoil generated in a new construction, or salvaged in a reconstruction project. An MRC value of 1 is

the ideal case, but in actual cases this is a fraction as not all of the salvaged material will be useful for the desired purpose.

$$\text{MRC} = \frac{\text{Material Recycled}}{\text{Total Material Generated}} \dots\dots\dots (3)$$

$$\text{ORT} = \frac{\text{Material Recycled}}{\text{Total Material Generated}} \times 1000 \dots\dots\dots (3b)$$

MRC is simple coefficient. Using 1000 Kg (1 tonne) as a standard scale, the unit of MRC is in kilogram per tonne. I call this Otto Recycling Tonnage (ORT) or *Otto Recyclage* and it gives an idea of the rate at which salvaged materials are recycled in a reconstruction project per 1000 tonne of demolition waste. Where there is a weight bridge, the computation of MRC is very simple and practical.

Usually, salvaged materials from demolition includes timber, concrete, glass, aluminum profiles, ceramics, gypsum finishes – for building, and asphalt, coarse aggregate, cobbles, stones, steel, concrete for road pavements. Apart from the concrete which is used for just the purpose of hardcore fill, other materials may be reused for the original purpose they served in the previous development. From this we can proceed to rank our recycling efforts through Material Recycled coefficients and Otto Recycled Tonnage as follows:

- MRC < 0.2 is poorly recycled                      and ORT < 200kg/Ton is poorly recycled
- MRC = 0.5 is fairly recycled                      and ORT = 500Kg/Ton is fairly recycled
- MRC > 0.5 is sustainably recycled              and ORT > 500Kg/Ton is sustainably recycled

Table 4

Material Recycled Coefficient (MRC)	Otto Recycled Tonnage (ORT)	Ranking
MRC < 0.2	ORT < 200kg/Ton	poorly recycled
MRC = 0.5	ORT = 500Kg/Ton	fairly recycled
MRC > 0.5	ORT > 500Kg/Ton	sustainably recycled

## 5. WORK MECHANIZATION LIMIT (WML)

As there are different pillars of sustainable development, so there are different indicators requiring neither sole methodology nor sole scale. Increase in employment creation through construction of infrastructures would enhance economic growth in terms of rich Gross Domestic Product (GDP) and reduce the gap between rich and poor, and hence increase social equity. In any case, applying the Work Mechanization Limit (WML) as an indicator for monitoring excessive mechanization, a standard limit has to be set, and construction projects have to be classified. However, the role of machinery in construction is vital and indispensable, since efficiency is of the essence to remain productive. The acquisition of plant and machinery is highly capital intensive, but there are acquisition options including purchase, hire, lease and hire purchase.

Construction, as an engineering process, is primarily a producer activity that comes into operation to satisfy human wants. This search involves both physical and economic processes in which a major objective is to maxima economic and physical efficiencies. A wholly manpower workforce may be profitable in economic terms even through its physical efficiency per unit of input and output may be relatively low. However, economic alternatives are feasible when they attain efficiencies greater than 100%. This may be expressed as efficiency (economic).

$$\text{Efficiency Economic} = \frac{\text{Output}}{\text{Input}} \times \frac{\text{Worth}}{\text{Cost}} \dots\dots\dots (4a)$$

In terms of work and labour,

$$\text{Efficiency Economic} = \frac{\text{Output}}{\text{Input}} \times \frac{\text{Value of Work}}{\text{Value of Labour}} \dots\dots\dots (4b)$$

Moving load up a simple inclined plane could have efficiency as much as 60% (i.e output /input of 0.6). In evaluating and acquiring machinery and labour as options, it would be necessary to consider whether the cost associated with the machinery is first cost or operational and maintenance cost. Where this is not the case, we should be concerned with lease rental/hire cost and operational and maintenance cost (depending on the terms of the lease). Even if labour is employed, it has to be supported by simple equipment like wheel barrow, head pans, etc. Therefore,

Labour Intensive Cost = Labour cost for operating personnel + simple equipment + transportation

Mechanised work cost or **Mechwork cost** = First cost + Operational and maintenance cost

or

Mechanised work cost or **Mechwork cost** = Lease /Hire cost + Operational and Maintenance cost

$$\text{Mechanized Work Limit, WML} = \frac{\text{Mechanized Work Cost}}{\text{Mechanized Work Cost} + \text{Manual Labour Work Cost}} \times 100\%$$

The numerator may be called **mechwork cost** ie mechanized work cost.

The Mechanized Work Limit will be decided when a regional council is constituted to establish standards.

## SITE REMEDIATION RETENTION

Assuming that the contractor met all project requirements so that 5% of his claims are retained as Site Remediation Retention (SRR), at the end of each month the progress payment would be billed less the SRR. Upon satisfactory completion of work, clean-up and remediation work, this retention fee will be paid to the contractor. This may be 5-7% of the project cost, depending upon how delicate is the ecosystem around the site

In summary, sustainability control in construction works through Site Remediation Retention may be exercised for the following reasons:

- (i) as a routine measure to ensure that the immediate working and surrounding environment retains their regenerative capacity;
- (ii) as a method of approving or deferring payment of site remediation retention to contractor.

## HUMAN CAPACITY BUILDING

A profile of UN's past efforts at stimulating economic growth in developing countries reveals that poorly developed human capacity was fundamental to low level of infrastructural and economic development in developing countries. According to Russel C. Jones, "Economic development for developing countries can



be effectively stimulated by building the technical capacity of their workforce, through quality engineering education programs". He outlined three desirable outcomes which technical capacity building efforts aim at effecting in developing countries through a cream of well educated and certified engineering graduates:

- Technical capability is needed for developing countries to engage effectively in the global economy; direct foreign investment, international trade, mobility of engineers, and the flow of work to countries with cost-effective talent will result.
- Indigenous science and technology capacity is needed to insure that international aid funds are utilized effectively and efficiently – for initial project implementation, for long-term operation and maintenance, and for the development of capacity to do future projects. And a sufficient pool of engineers can enable a developing country to address the UN's Millennium Development Goals effectively, including poverty reduction, safe water and sanitation, etc.
- In order to stimulate job formation in developing countries, a technical workforce pool is needed, made up of people who are specifically educated and prepared to engage in entrepreneurial startup efforts that meet local needs.<sup>[14]</sup>

These were the words of Kofi Anan in his 2005 report "In Larger Freedom" on the dilemma of developing countries:

*"Let me challenge all of you to help mobilize global science and technology to tackle the interlocking crises of hunger, disease, environmental degradation and conflict that are holding back the developing world."*

*- Kofi Annan, 2002.<sup>[15]</sup>*

I am convinced that universities are vastly underutilized, which otherwise should have been potentially powerful vehicles for development in developing countries, particularly with respect to science and technology. If both universities and industry are encouraged to work actively together, universities will be able to assume new roles that could accelerate local and national development. To render these institutions more effective as key development partners will require structural changes at different levels of university administration and education.

Government will need to play key role as the facilitator of partnerships between these two vital actors. According to Jones "If this is achieved, the 'loneliness syndrome' that for so long affected universities in developing countries will be redressed, allowing them to contribute to economic growth and social development."

In a detailed study of the results of foreign aid to developing countries over the past several decades, William Easterly concludes, in his book "The Elusive Quest for Growth" that past efforts at stimulating economic growth in developing countries have failed. He outlined what he thought would work which he argues are two areas that can likely lead to the desired economic growth in developing countries, and can lead them toward economic self sufficiency:

- utilization of advanced technologies, and
- education that leads to high skills in technological areas

China, which is recognised as a major economic power, has a proportion of first science and engineering degrees to all bachelors-equivalent degrees to be 59%, as compared to about 33% in the US in 2001 (Source: *Science and Engineering Indicators 2004*).<sup>[16]</sup>

## **SNAKE ISLAND INTEGRATED FREE ZONE DEVELOPMENT PROJECT: A CASE STUDY**

Snake Island was a new experience for me, and there is really so much to delight in the entire port development project. But for reason of space I will present a highlight on the different aspects that is noteworthy.

*“The first major breakthrough in opening up the Lagos Lagoon was in 1906 when orders were placed for dredgers to work at the bar. During the same year, approval was given for the construction of the first length of the East Mole. The construction of railway from Lagos to Otta and then to Abeokuta provided easy transportation of stone needed for the construction of the mole. Depths over the bar improved steadily as the entrance moles were pushed further sea words. Decision to develop Apapa Port was taken in 1913 and construction of the first four deep-water berths of 548.64 metres long at Apapa began in 1921”.*<sup>[17]</sup>

### **(1) Local Content Policy**

The Nigerian Oil and Gas Industry Content Development (NOGICD) Act, which was signed in August 2010, had set objectives of creating employment, developing technology and increasing added value in-country. Nigerdock supposedly is the ‘champion’ of Nigerian Content and skills development is at its core. The completed Nigerian National Petroleum Corporation (NNPC) and Mobil Producing Nigeria Unlimited (MPNU) Joint Venture’s Satellite Field Development Project Platforms, was the first fruit of the (NOGICD) Act. With the two platforms fabricated and installed with 100 per cent Nigerian manpower and content by Nigerdock and Jagal Group for ExxonMobil Production, Nigerian oil and gas sector will longer depend on foreign countries for facility procurement and manpower.<sup>[18]</sup>

### **(2) TRANSPORTATION SYSTEM**

Over 350 personnel work on the Snake Island Integrated Free Zone daily, but 4 out of every 5 personnel working on the site ride a bicycle from the jetty point to various locations of work. However, there are about three crew buses transferring workers to the locations. But I think the carbon energy saving is significant viewed from the current trend of transport elsewhere.

### **(3) HEALTH, SAFETY AND ENVIRONMENT**

At locations there would be caution signs, barricades, warning notes, etc – to ensure that accident and incidents are checkmated. The recent Satellite Field Development Project Platforms construction involved over 2.5 million man-hours without any lost time incidents. This impressive performance earned Nigerdock a prestigious safety award by Mobil.

### **(4) WASTE MANAGEMENT**

Daily, several tones of metal scraps are generated and recycled. They are loaded into trucks and shipped out of the project site. Other waste categories such as concrete, plastics, and food waste are dropped off at the African Circle Pollution Management site, where they are presorted and segregated.

### **(5) GREEN DEVELOPMENT PLAN**

A close view of the manner in which development is carried out on the Snake Island base of Nigerdock suggests that the planners, designers have understanding of the primal roles that trees play in the environment and in our lives – be it domestic or industrial. I refer to the site as **“industrial park”**.

## THE PATH TO SUSTAINABLE CONSTRUCTION

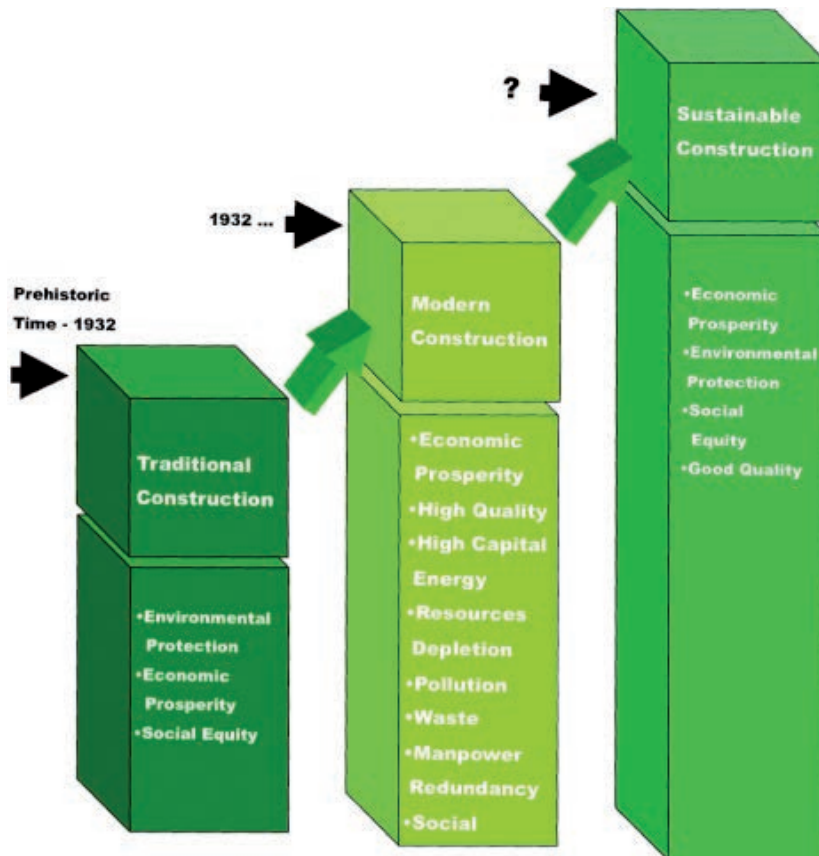

Fig. 1. Albert Otto's concept of the Path to Sustainable Construction in Nigeria.

## RECOMMENDATIONS

*Government agencies and all the institutions that regulate, monitor and control materials, labour, construction works and environmental quality should prepare programmes of action within the existing environmental framework. Therefore, appeal is made to Nigerian and other African governments to involve engineers in sustainable development and environmental policy making positions, which are fundamental to infrastructural development.*

*Designers should consider long-term affordability of buildings and infrastructures and the embodied energy of their components to achieve maximum environmental, cost and aesthetic standards.*

*An environmental remediation retention clause and environmental questionnaire should be integrated into the body of tender documents as part of the contractual arrangements.*

*Addressing the impacts of construction in the future will require producing engineers and project managers with up-to-date knowledge of climate change, sustainable materials, alternative energy resources and eco-friendly processes, using the instrumentality of graduate schools working with industry and centres that provide interdisciplinary approaches to teaching and research.*

*Finally, an international commission of African Union should be constituted to liaise with research, centres, universities and professional bodies concerned to formulate some methodologies, to accelerate progress on our environmental sustainability efforts, and reach regional consensus on appropriate methodologies and establish database for rating embodied energy and monitoring the sustainability in the construction industry.*

## CONCLUSION

Whether we consider environmental degradation, discuss emission to air, and contamination of water and land in our environmental policy, it is clear that the construction industry of Nigeria and most African countries have not yet responded to these challenges. Sustainable construction cannot be achieved on the periphery, but requires an integrated approach and revolutionary change in the pattern infrastructures are created. **Everyone wants a sustainable environment, and everyone wants a sustainable economy, but not everyone wants to live a sustainable life.** The environmental revolution is sure to curb climate change, for it is featuring some contributing changes in technologies and lifestyles: some developed countries contribute by modifying processes, methodologies, policies and standards; great animals contribute by adapting; we Africans must adopt green technologies, less we should be left in the lurch like the five foolish virgins late to the marriage feast.

I hope that this work on sustainable construction will be helpful and suggestive in building a sustainable society. There are still a number of challenges and much work, to be done in making the concept fully operational, especially, in achieving the political and technical support for the very novel and difficult decisions that are necessary to be taken.

## REFERENCES

- [1] 2005. Investment conference in construction and Civil Engineering Central and West Africa.
- [2] Ibid
- [3] Williams, Ofoni (2010) 'Open Letter to the Honourable Minister of Environment of the Federal Republic of Nigeria, Mr John Odey' in *The Environment Outreach* Vol.No5, April-June, 2010.
- [4] Brundtland, G. (ed) (1987) *Our Common Future: The World Commission on Environment and Development*, Oxford University Press.
- [5] Vale, Brenda and Robert (1993) 'Building the Sustainable Environment' in Blowers, Andrew (ed) *Planning for a Sustainable Environment*, Earthscan, London
- [6] Kibert, Charles J. (2008) *Sustainable Construction: Green Building Design and Delivery*, John Wiley & Sons Inc, New Jersey
- [7] [http://en.wikipedia.org/wiki/Embodied\\_energy](http://en.wikipedia.org/wiki/Embodied_energy)
- [8] Kibert, Charles J. (2008), op. cit.
- [9] Brow, H. T. and S. Ulgiati. (1999) 'Energy accounting of human-dominated, large scale ecosystems' in Jorgensen and Kays (eds) *Thermodynamics and Ecology*, Elsevier
- [10] International Energy Agency [IEA] (2006) *World Energy Outlook*. Available: [www.iea.org/textbase/nppdf/free/2006/weo2006.pdf](http://www.iea.org/textbase/nppdf/free/2006/weo2006.pdf)
- [11] DoE (1992) *Environment in Trust: Global Atmosphere and Air Quality*, HMSO, London
- [12] NEF. *Simple Carbon Calculator*. Available: [www.nef.org.uk/greencompany/CO<sub>2</sub>\\_calculator.htm](http://www.nef.org.uk/greencompany/CO2_calculator.htm)
- [13] [http://en.wikipedia.org/wiki/Embodied\\_energy](http://en.wikipedia.org/wiki/Embodied_energy)
- [14] Jones, Russel C., "Engineering Capacity Building" in *The Nigerian Society of Engineers – Proceedings of the the 2007 International Conference and Annual General Meeting*.
- [15] Anan, Kofi, "In Larger Freedom", 2005 report of the UN Secretary General, <http://www.un.org/largerfreedom/>
- [16] Easterly, William, *The Elusive Quest for Growth*, MIT Press, Cambridge MA, 2002.
- [17] [www.nigerianports.org/dynamicdata/uploads/OurHistory.pdf](http://www.nigerianports.org/dynamicdata/uploads/OurHistory.pdf)
- [18] [http://www.compassnewspaper.org/index.php?option=com\\_content&view=article&id=987:fg-mobil-nigerdock-count-gains-of-local-content&catid=69:business-news-&Itemid=220](http://www.compassnewspaper.org/index.php?option=com_content&view=article&id=987:fg-mobil-nigerdock-count-gains-of-local-content&catid=69:business-news-&Itemid=220)

# **Disaster Risk Management**





## **Prof. Kazutoshi Kan<sup>(1)</sup>, Kazutoshi Osawa<sup>(2)</sup>, Japan**

207

KAZUTOSHI KAN

### **The Influence of Development on the Amount of Red-Clay Runoff in the Republic of Palau**

<sup>(1)</sup> Professor, Department of Civil Engineering, Shibaura  
Institute of Technology,

<sup>(2)</sup> Associate Professor, Faculty of Agriculture, Utsunomiya  
University

E-mail: [kan@sic.shibaura-it.ac.jp](mailto:kan@sic.shibaura-it.ac.jp)

#### **ABSTRACT**

Much red clay is transported to a bay by development, and it is anxious about the influence of the natural environment on a coral reef etc. in Republic of Palau.

A lot of red clay runoff has been generated in the past experience with airport construction, and the balance of development and environmental preservation is an important issue in Palau.

I am building the simulation model to predict the amount of red-clay runoff by changing the land use pattern.

In order to examine the adaptability of this model, the amount of red-clay outflows from the land developed for housing lots under development is now measuring.

Lack of the counter measure to a development process caused a large-scale collapse and a lot of red-clay outflows generating.

I would like to introduce the situation of outflow process from viewpoint of risk management.

## 1 INTRODUCTION

Republic of Palau has two development strategies. One is the increase in the population by attraction of foreign company. I supposed, it is difficult to manage a country with present population 20,000 persons. Therefore increase of population is important issue. For these purposes, development of a residential section and a company lot are needed. The change of land use pattern will induce the increase of clay runoff and affects to natural environment and coral reef.

And second strategy is the increase in the tourist who utilized natural environment. These much tourist's impact to natural environment will overflow compared to acceptable environmental capacity in a near future.

The development activities will induce the economic development but these activities influence to the natural environmental acceptable capacity.

A lot of red clay runoff has been generated in the past experience with airport construction, and the balance of development and environmental preservation is an important issue in Republic of Palau.

The impact of human activities to natural environments increases the environmental destruction risk gradually for a long period. Lack of the counter measure to a development activity caused a large-scale collapse and a lot of red-clay outflows generating.

I am building the simulation model to predict the amount of red-clay runoff by changing the land use pattern. In order to examine the adaptability of this model, the amount of red-clay outflows from the developing housing lots is now measuring.

I would like to introduce the situation of outflow process from viewpoint of risk management.

In the ocean, a coral reef constitutes the precious ecosystem while having appearance value. However, 50% is exposed to the crisis in the country where 22% of the coral reefs in the world are subject to the influence of contamination of soil erosion and land origin, and exploitation in a land area progressed now.

In Republic of Palau belonging to Micronesia "The Micronesia challenge" is declared with each country and surrounding area and it aims at being put under the protection with 20% and 30% of a coastal area and forest resources by 2020.

However, the land development by foreign capital is advancing at the Ngerikiil watershed in Airai State.

To the Airai bay, mud accumulates at the rate of 1.5 t/ha/yr, and the coral reef is covered with mud.

Moreover, it is indicated that the amount of deposition and concentration of suspended substance (SS concentration) in a river mouth region have a correlation to the number of individuals and individual density of coral and the sediment discharge from a land area is regarded as questionable.

So, in this research, we want to estimate the amount of sediment discharge from a land area and land development area to clarify the influence to the sediment discharge.



Fig.1 Observation point in the Ngerikiil River



Fig.2 Observation point No.3



## 2 THE OUTLINE OF AN OBSERVATION POINT

The land development by foreign capital is advancing at the Ngerikiil watershed in Airai State. I supposed that the residential land development continues to advance in this watershed, therefore we selected the Ngerikiil River for the observation point.

However, in order not to use a river for agriculture etc., the river is flowing in the jungle, and selection of observation points was very difficult. The Ngerikiil River flows through the Airai State of southern Babeldaob Island, and watershed area is 21.86km<sup>2</sup> and consists of nine small sub watershed.

Research zones are two small sub watershed shown in Fig. 1, and the water depth gauge, the turbidity meter, and the current meter were installed at the points 3 and 4.

The rain gauge was set at the residential section of a village.

Moreover, the camera which observes the situation of a flow was installed in the points 3 and 4.

Furthermore, the camera was installed in order to grasp the situation of gully generation, development of gully, slope sliding, and sediment discharge.

Data is stored in each measurement apparatus at intervals of 10 minutes and 20 minutes.

Acquisition of data and the maintenance of apparatus are performed around about three months.



**Fig.3** Observation point No.4



**Fig.4** The situation of the land development

## 3 SEDIMENT RUNOFF PROCESS

The situation of the land developed for housing lots is shown in Fig. 4.

In land developed for housing lots with an inclination, big gully was formed and collapse and a red-clay runoff are repeated at the time of heavy rain.



**Fig.5** The easy fence for protecting clay runoff



**Fig.6** High turbidity inflow from tributary



**Fig.7** Inflow from development area by small tributary channel

The easy fence is installed in many steps along the small tributary channel so that this red clay may not flow out to a river channel, but it is in an almost full state. This situation is indicated in Fig.5. Fig.6 shows this high turbidity inflow situation and Fig.7 shows the inflow situation of small tributary channel which flow down from development area.

In the case of heavy rain, red clay flows into the small tributary channel, and exceeding this fence, and a part accumulates and it is flowing into the river (observation point No.4) as high turbidity water. By the water level rise in the main river, the river water also enters a small tributary channel.

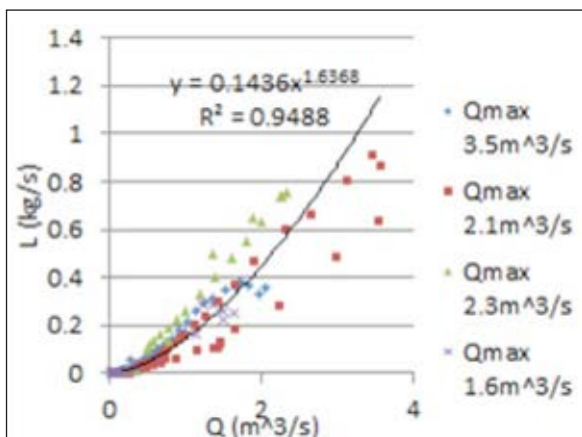

**Fig.8** L-Q curve at the upstream point No.3

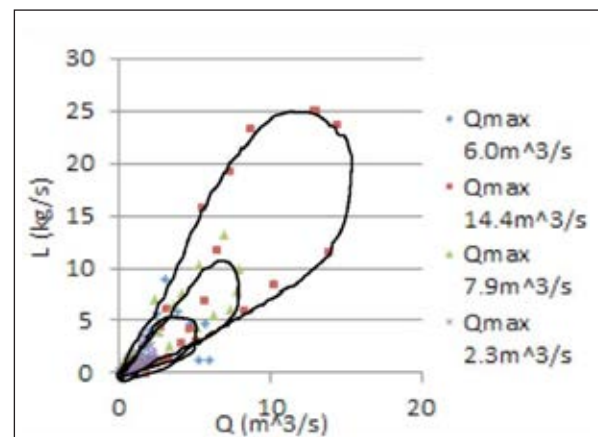

**Fig.9** L-Q curve at the upstream point No.4

The high turbidity water stored in tributary channel at high water level period and this high turbidity water flow out in the period of water level decreasing. Therefore high turbidity water is observed in spite of non-rain period.

Fig. 8 shows the L-Q curve at the upstream point No.3.

This figure shows that the sediment transported load L is proportional to discharge Q. The discharge Q can be estimated by using H-Q curve. Therefore, the estimation of sediment transported load is possible by only measuring water depth. This runoff process is simple and general.

Fig. 9 shows the L-Q curve at the downstream point No.4.

The curve indicates the loop shape by reflection of complex runoff process as previously mentioned. The maximum turbidity appeared before maximum discharge appeared.

The discharge  $Q$  and sediment transport load  $L$  were made dimensionless respectively by the maximum  $Q_{max}$ , and maximum sediment transport load  $L_{max}$ . The relation of two dimensionless factors was indicated by single loop curve as shows in fig.6.

Table. 1 Land use area in the watershed

	upstream region	downstream region
water shed area	99 ha	72 ha
forest area	49 ha	16 ha
grass land area	50 ha	52 ha
developed area		3 ha

Table. 2 Amount of sediment runoff

upstream region	312.9 t/yr	3.13 t/ha/yr
downstream region	1991 t/yr	27.6 t/ha/yr
developed area	177.39 t/yr	669 t/ha/yr



Fig.10 The rain gauge in developed area

This shows that the process of sediment runoff has similarity even though the maximum discharge was changed.

#### 4 AMOUNT OF SEDIMENT DISCHARGE

The amount of annual sediment discharge was calculated using observation data of SS and discharge  $Q$ . The result was shown in table 2. In the upstream region, amount of sediment runoff is 312.9t/yr and amount of per unit area is 3.13t/ha/yr.

In the downstream region, amount of sediment runoff is 1991.1t/yr and amount of per unit area is 27.6t/ha/yr. The amount of per unit area at downstream was about 10 times the amount of upper region which consists of a forest and a grassy place. In addition, annual precipitation was 4605 mm.

By assuming the amount of sediment discharge per unit area from undeveloped area is comparable to the amount of upstream region, sediment discharge from developed area was calculated as 669 t/ha/yr.

This amount from developed area is also about 200 times as compared with 3.13 t/ha/yr of an upper region, and implementation of the effective measure against sediment discharge control in land developed for housing lots is required.



**Fig.11** The outflow of the stored red clay



**Fig.12** New deposition at a river mouth

In the observation in February, 2012, the fence which was storing red clay was destroyed and a lot of red clay was flowing into the observation point No.4.

This situation is shown in Fig. 11.

The river bed of No.4 point was rose about 10 cm by this outflow, and a part of a fine clay was conveyed to the river mouth.

As shown in Fig. 12, new deposition was seen at the river mouth.

## 5 THE MEASURES FOR SEDIMENT DISCHARGE CONTROL

For consideration of the counter measure for the sediment discharge control from developed area, model calculation by WEPP (Water Erosion Prediction Project model) was performed. Geographical feature is selected as simple slope and terrace feature.

Situation of earth surface condition were selected as bare land and grass land. The combination of geographical feature and situation of earth surface was indicated as follows.

- 1) Case 1  
Simple Slope and Grassland
- 2) Case 2  
Simple Slope and Bare land
- 3) Case 3  
Terrace and Bare land
- 4) Case 4  
Terrace and Slope Seeding
- 5) Case 5  
Terrace and Grassland

The present condition of land developed for housing lots is equivalent to the bare land with terrace as geographical feature.

The application result was shown in Table 3.

In the case of the grassy place, the calculated amount was 2 t/ha/yr, and it became 1386 t/ha/yr in the case of simple slope and bare land.

In the case of the terrace and bare land, the calculated amount was 780 t/ha/yr. It was reduced by 44% by making terrace geographical feature from a simple slope with bare land. And the calculated value was approached to observed value 669 t/ha/yr.

In addition, in the case of the terrace and slope seeding, the calculated amount was 53 t/ha/yr. It was reduced by 93% by slope seeding with terrace.

In addition, when using a WEPP model, meteorological data incorporated and created the observed value and the other various data used the existing data (it receives from USDA).

Table.3 Calculated results by WEPP model

1) Case 1 Simple Slope and Grassland	2 t/ha/yr
2) Case 2 Simple Slope and Bare land	1386 t/ha/yr
3) Case 3 Terrace and Bare land	780 t/ha/yr
4) Case 4 Terrace and Slope Seeding	53 t/ha/yr
5) Case 5 Terrace and Grassland	21 t/ha/yr

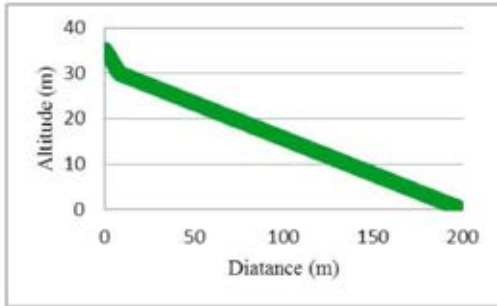

Fig.13 Case 1 Simple Slope and Grassland

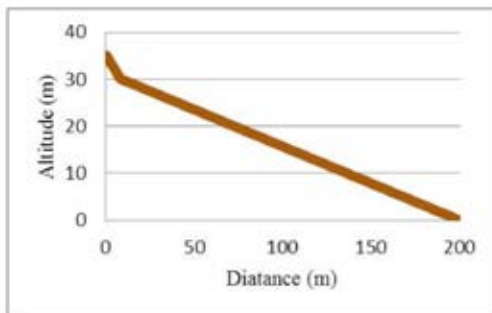

Fig.14 Case 2 Simple Slope and Bare land

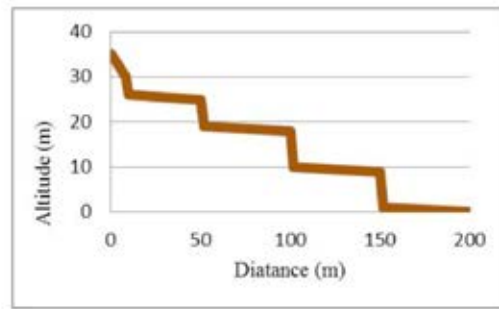

Fig.15 Case 3 Terrace and Bare land

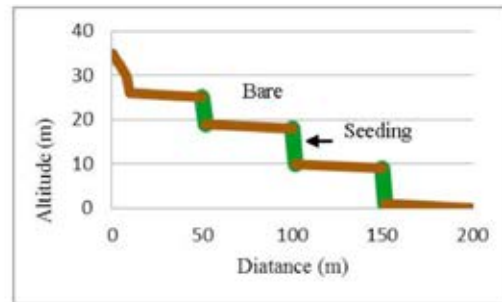

Fig.16 Case 4 Terrace and Slope Seeding

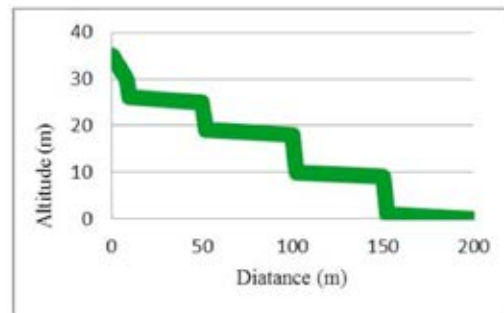

Fig.17 Case 1 Terrace and Grassland

In the case of the grassy place, the calculated amount was 2 t/ha/yr , and it became 1386 t/ha/yr in the case

The form of land developed for housing lots was created based on geographical feature data (it receives from USDA), and GPS data, and was made as 200 m square, and 15% of an average slope.

## 6 NATURAL DISASTER RISK

Damage risk to natural disaster can be expressed by using following factors.

Damage Risk = (1) damage intensity of disaster

(2) probability of occurrence

(3) probability of encounter

(4) suffering duration time

(5) Acceptability and adaptability to a disaster.

The damage intensity will increase by unpredictable hard disaster which is induced by climate change.

It is important to decrease this intensity by balance of hard and soft measures.

Probability of occurrence will increase but it is impossible to decrease this probability.

Probability of encounter will increase but the probability of encounter can be reduced by education for evacuation drill and knowledge for disaster prevention.

The storm and flooded suffering time will become long.

By analogy to this damage risk equation, the risk management owing to land development can be considered.

The sediment runoff from development area will increase the sediment runoff as previously mentioned. The unpredicted heavy amount of sediment runoff is transported to a river mouth and it spread into a bay. This transported clay will influence to a natural environment especially to an individual density of coral. To decrease the influence risk, the scale of development area, development point in watershed, development step, and mitigation measure have to consider.

Land development process with terrace and with slope seeding can decrease the amount of sediment runoff. To protect the occurrence of gully at seeding slope, drainage measure is very important.

In order to decrease the influence risk of artificial activity, it is necessary to clarify the relationship of each influenced factors which occurred by artificial activity, and cutoff of the influence chain is need.

The transportation of traditional and fundamental technical knowledge is an important issue from a viewpoint of capacity building in a developing country like a Republic of Palau.

And to increase the natural acceptable capacity against the development, the ecological tourism is an important measure.

## 7 CONCLUSION

Land development contributed to the generation of the sediment discharge in a watershed, and the remarkable big amount of sediment discharge was observed at downstream from land developed for housing lots as compared with the watershed which consists of a forest and a grassy place.

Moreover, as a result of presuming the amount of sediment discharge from developed area for housing lots, it was the amount of sediment discharge of 669 t//yr per unit area.

In order to work on the effective measure against sediment discharge control in land developed for housing lots, analysis by a WEPP model was conducted.

The result has checked the effectiveness of terrace geographical feature and the usefulness of slope protection.

In order to examine the suitable land development scenario aiming at the sustainable development of Republic of Palau from now on, watershed scale analysis is required.

## ACKNOWLEDGMENT

This research is done by research team's observation by the grants in aid of Ministry of Education, Culture, Sports, Science and Technology Japan.

Moreover, in observation at Republic of Palau, assistance of the local research auxiliary person and helpful assistance by residents of Japanese were received.

I would like to express gratitude.

## REFERENCES

- Bryant (1998) Reefs at risk : A map-based indicator to threats to the world's coral reefs. Washington, DC, World Resource, Institute.
- Bourke (2002) Reefs at risk in southeast Asia. Cambridge, World Resource Institute.
- Golbuu et al (2003) Trapping of Sediment in a semi-enclosed bay, Palau, Micronesia. *Estuarine Coastal and Shelf Science* 57, 941–949.
- Golbuu et al (2011) River discharge reduces reef coral diversity in Palau, *Marine Pollution Bulletin*.
- Sato and Kan et al (2011) The influence of Land development to the Sediment Runoff in Republic of Palau, Japan Society of Civil Engineering, Annual meeting.
- Kudo and Osawa et al (2012) Sediment Runoff from Land Development in Republic of Palau, The Japanese society of Irrigation, Drainage and Rural Engineering, Annual meeting

# Dr. Marlene Kanga, Australia



215

MARLENE KANGA

## Systematic Natural Disaster Risk Management for Sustainable Development

Engineers Australia

E-mail: [marlenekanga@bigpond.com](mailto:marlenekanga@bigpond.com)

### ABSTRACT

The increasing trend in the number and severity of natural disasters has increased the level of devastation and loss to people all around the world. These events threaten the sustainable development and security of people. The application of sound principles of natural disaster risk management is therefore becoming increasingly important.

This paper will present an overview of systematic natural disaster risk management and the role of both structural and non-structural measures for sustainable construction and development. The use of such measures, supported by high level government policy, is important for all countries but especially less developed ones where widespread damage after a natural disaster has a significant human and economic cost.

This paper will present some approaches to natural disaster risk management used by different countries around the world and demonstrate the benefits of good practices for sustainable development.

## 1 INTRODUCTION

The increasing trend in the number and severity of natural disasters has increased the level of devastation and loss to people all around the world. These events threaten the sustainable development and security of people. The application of sound principles of natural disaster risk management is therefore becoming increasingly important.

This paper presents an overview of systematic natural disaster risk management and the role of both structural and non-structural measures for sustainable construction and development. The use of such measures, supported by high level government policy, is important for all countries but especially less developed ones where widespread damage after a natural disaster has a significant human and economic cost. This paper presents some practical approaches to natural disaster risk management and demonstrates the benefits of good practices for sustainable development.

## 2 WHY FOCUS ON NATURAL DISASTERS?

There is an increasing trend in both the number of natural disasters due to meteorological causes due to climate change and an increase in the cost of these due to higher population densities in urban areas exposed to such events. Increased impacts of events such as flooding, cyclones and earthquakes are having a significant impact on the economies of developing countries.

## 3 INTERNATIONAL ACTION FOR NATURAL DISASTER RISK MANAGEMENT

Many international organisations, including the United Nations, are involved in natural disaster risk management. International collaboration provides opportunities to share experience and knowledge from specific events around the world. This is particularly useful because natural disasters such as earthquake and volcanic eruptions are relatively infrequent with long return periods. It is therefore important to share experience from actual events when they occur. International agencies are able to engage with national governments at a high level to drive the implementation of appropriate policies for natural disaster risk management, based on this experience. There is also a need to inform the next generation of engineers who have not had first-hand experience of natural disasters of the consequences that can occur so that they can apply the lessons learned to the design and construction of buildings and infrastructure which have the necessary resilience. This is critically important for sustainable development and to minimise the costs of natural disasters.

Many international agencies such as the OECD, the UN International Strategy for Disaster Reduction (UN-ISDR) and the World Federation of Engineering Organisations Committee for Disaster Risk Management, have recognised the need for natural disaster risk management by establishing specific programs in this area, including capacity development in natural disaster risk management for developing countries. The Millennium Goals declared in 2000 – also express the need for systematic natural disaster risk management for sustainable development.

The UN- ISDR was established in 2000 and declared the Hyogo Framework for Action in 2005. These priorities include the establishment of organisational, legal and policy frameworks for natural disaster risk management. These are intended to support systematic assessment of natural disaster risks through formal risk identification and assessment. Risk mitigation measures include the development of monitoring and early warning systems, community education, implementation of risk reduction measures and the development of effective response and recovery plans. The signatory countries report on progress in implementing the Hyogo Framework for Action, thus resulting in a gradual improvement in the management of natural disaster risks. The UN-ISDR Global Platform for Disaster Risk Reduction will hold its Fourth Session in May 2013 where it will review progress made since 2005.



## 4 SYSTEMATIC NATURAL DISASTER RISK MANAGEMENT

Many organisations and national bodies have developed systematic approaches to natural disaster risk management. An example of such a process, developed by the Newcastle City council, is shown in **Figure 1**. The international standard on risk management, ISO31000:2009, describes the systematic process that can be applied to natural disaster risk management.

Some of the elements of the natural hazard risk management process are:

- **IDENTIFY NATURAL HAZARD RISKS** – this includes, for example, mapping of seismic faults, documenting the history of occurrence of major events – tsunami, earthquake, floods. This assists in identifying the likelihood or probability of occurrence of natural hazard events. The consequences of such events can be severe and include damage to property, injury and loss of life and disruption to the economy. The cost of recovery can be significant and have an adverse impact on the development of a country.
- **ASSESS RISKS** – this involves combining the assessment of the likelihood and consequences of various natural hazard events to determine which risks are the most significant. Priorities for actions can be developed to address the most severe risks first. As there is often complex data involved, a qualitative approach, such as described in the international standard on risk management, is usually sufficient to establish priorities for such action plans.
- **PLAN MITIGATION ACTIONS** – this may include structural measures such as the construction of sea walls, river improvement measures or flood control structures and non-structural measures such as the implementation of, for example, city planning frameworks, flood plain management, and appropriate building codes.
- **COMMUNICATE RISK MATTERS TO COMMUNITY** – this is important for effective planning prior to an event and effective response during an event. Actions may include early warning systems, emergency planning and various types of public awareness campaigns.
- **RECOVERY SYSTEMS** – this may require international and domestic resources, technical, and financial and additional support measures such as national funds and insurance.
- **REVIEW** – this is important to ensure that changes such as development patterns, demographics, economic growth, climate change and other factors are included in the risk management plans.

## 5 CASE STUDY – FLOOD RISK MANAGEMENT IN AN URBAN AREA

Newcastle City, located on the east coast of Australia north of Sydney, is exposed to frequent river and coastal flooding. The Hunter River flows through the city and there are many estuaries and lagoons within the city area. The Newcastle City Council have taken a systematic approach for natural hazard risk management over many years and have recently released their draft report on flood risk management for public comment.

The planning process includes consideration of the likelihood of events from historical records and the consequences of such events from modelling of expected inundation depths from river and coastal floods for various return periods. Risk mitigation options are considered including the effectiveness of current measures. The activities of the City council in informing the community and involving them in the consideration of proposed options are commendable. There is a frank discussion of the hazards and a high likelihood of community acceptance of the measures proposed including the costs and benefits. The current

plan is a review of the previous plan developed in 2004, demonstrating the cycle natural hazard risk management process and the consideration of new and emerging issues such as climate change.

## 6 CASE STUDY – CYCLONE RISK MANAGEMENT IN A REMOTE AREA WITH CRITICAL FACILITIES

The coast of North West Australia, the Pilbara Coast, is exposed to frequent cyclones, more than any other part of Australia. Since 1910 there have been 49 major cyclones, about one every two years. Seven of these, caused very destructive wind gusts in excess of 170 km/h, approximately one every ten years. Along the Pilbara coast the cyclone season runs from mid December to April peaking in February.

Major oil and gas and iron ore facilities operated by large companies such as Rio Tinto, Woodside Petroleum and others are located on the Pilbara Coast. In particular, Port Hedland and Karratha are two small townships that are host to billion dollar projects in these sectors. Although these areas are sparsely populated with a population of less than 50,000, comprising mainly of indigenous communities. There are a few thousand shift workers who fly in and out of the area on a two weekly roster.

It is interesting to note that Port Hedland and Karratha are at the centre of the cyclone tracks as shown by historical records. The cyclones that impact these townships typically form over warm ocean waters to the north. Although the typical initial steering of these systems is to the southwest, some tend to take a more southerly or southeasterly track as they move further south. These townships have been exposed to very strong winds with the strongest wind gust recorded at Port Hedland during a cyclone is 208 km/h during TC Joan in 1975.

The natural hazard risk management for these facilities have been done by the corporations that own these facilities. The likelihood is established from historical records and the consequences are the loss of high value investment and revenues as well as injury and loss of life to employees. Cyclonic activity may cause flooding which can result in pollution and environmental damage. The companies have used mainly structural measures to mitigate risks, that is the facilities have been designed to withstand strong winds exceeding 200 km/hour. Early warning systems from the Australian Bureau of Meteorology and formal emergency plans including tie-down procedures are in place. The community is informed of precautions to be taken and there is extensive consultation with employees. For example, the cyclone alert system is broadcast via various media and the Australian Bureau of Meteorology posts regular updates via its website. The companies regularly review their natural hazard risk management plans. Regular inspections and maintenance of facilities and emergency exercises are part of this activity.

## 7 CONCLUSION

There are many examples of good practices for natural disaster risk management, especially in developed countries. It is important to share this information and build capabilities in this area with communities and countries which are still developing their knowledge in this area. Such knowledge transfer is facilitated by the activities of international organisations such as the World Federation of Engineering Organisations Committee on Disaster Risk Management. The use of cost-effective risk management measures is expected to assist many countries in mitigating the impact of natural disasters and to recover with least disruption to their people and their economies.

Figure 1: Natural Hazard Risk management Process (Source: Ref No. 5)

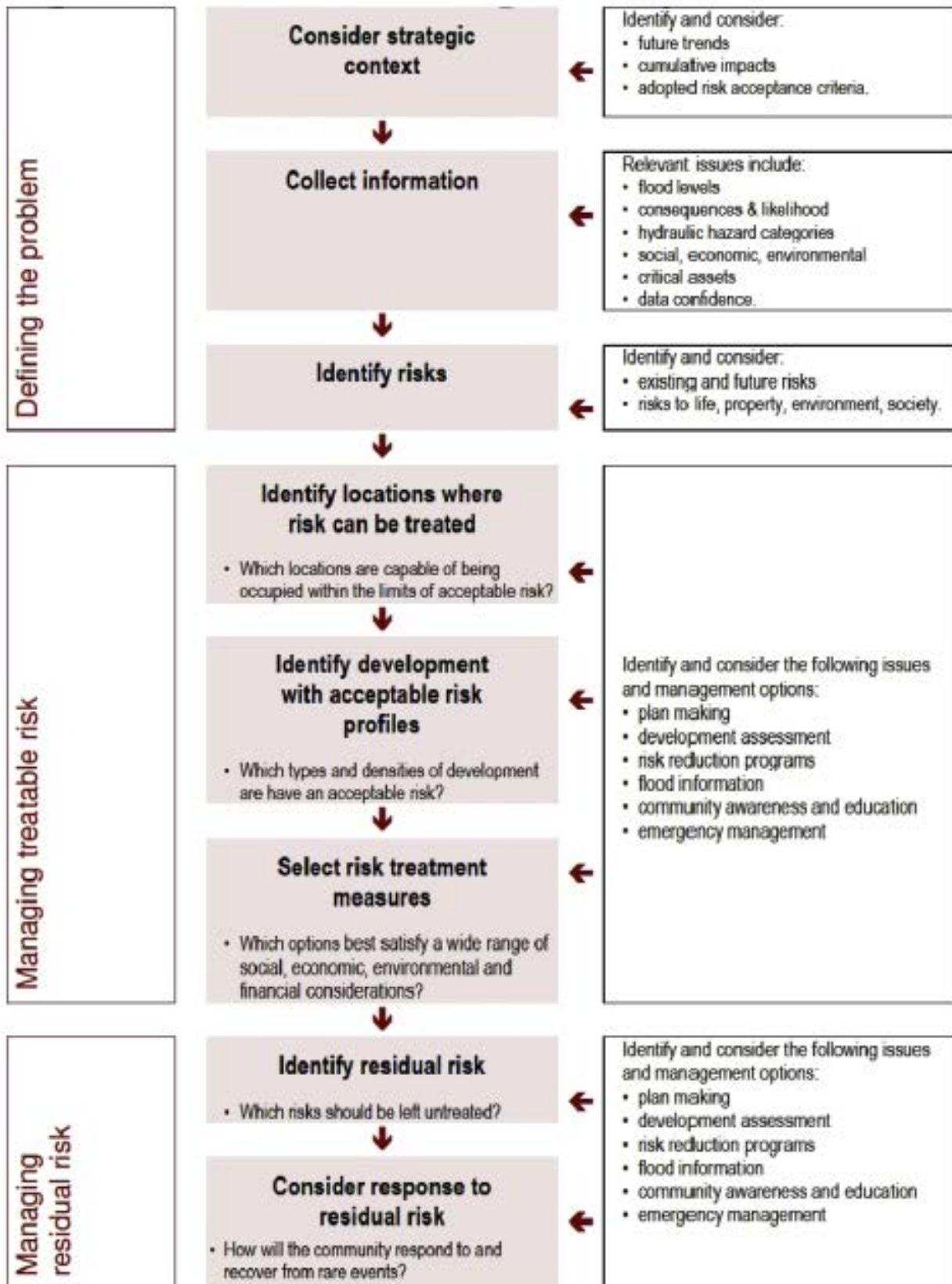

## REFERENCES

### International Resources:

1. CatNet TM by SwissRe, Global Risk mapping Tool, available from: [www.swissre.com/catnet](http://www.swissre.com/catnet), subscription required.
2. International Standard on Risk Management, ISO 31000:2009, available from [www.saiglobal.com](http://www.saiglobal.com).
3. Munich Re Natural Hazard Mapping, available from: [www.munichre.com](http://www.munichre.com), subscription required.
4. United Nations International Strategy for Disaster Reduction (Un ISDR), Hyogo Framework for Action 2005-2015: Building the Resilience of Nations and Communities to Disasters, available from: <http://www.unisdr.org/hfa>.

### Case Study: Newcastle City, Australia, Urban Flood Risk Management

5. BWT WBM Consultants, "Newcastle City-wide Floodplain Risk Management Study and Plan, Draft Report, January 2012, available from: [http://www.newcastle.nsw.gov.au/environment/flooding\\_and\\_waterways/draft\\_newcastle\\_citywide\\_floodplain\\_risk\\_management\\_study\\_and\\_plan](http://www.newcastle.nsw.gov.au/environment/flooding_and_waterways/draft_newcastle_citywide_floodplain_risk_management_study_and_plan).
6. BWT WBM Consultants, Flood Maps for Newcastle City wide Floodplain Risk Management Study and Plan, Draft Report, January 2012, 1% Annual Exceedance Probability Flood Depths available from: [http://www.newcastle.nsw.gov.au/\\_data/assets/pdf\\_file/0008/189512/Map\\_Series\\_2\\_v2.pdf](http://www.newcastle.nsw.gov.au/_data/assets/pdf_file/0008/189512/Map_Series_2_v2.pdf).
7. Newcastle City Council, community information and consultation, available from: [http://www.newcastle.nsw.gov.au/environment/flooding\\_and\\_waterways](http://www.newcastle.nsw.gov.au/environment/flooding_and_waterways).

### Case Study: Pilbara Coast Western Australia, Cyclone Risk Management

8. AAP Media story "Red Alert Residents on Lockdown as They Brace for Cyclone Lua, March 2012, <http://www.news.com.au/breaking-news/red-alert-residents-on-lockdown-as-they-brace-forcyclone-lua/story-e6frfku0-1226302485904>.
9. Australian Government Bureau of Meteorology, Tropical Cyclones Affecting Port Hedland, available from: <http://www.bom.gov.au/cyclone/history/wa/pthed.shtml>.
10. Australian Government Bureau of Meteorology, Tropical Cyclones Affecting Dampier, Karratha, Roebourne region, available from: <http://www.bom.gov.au/cyclone/history/wa/roebourne.shtml>
11. Australian Government Bureau of Meteorology, Tropical Cyclones Warning system, available from: <http://www.bom.gov.au/cyclone>.
12. Fire and Emergency Services Authority (FESA), WA State Emergency Plan for Tropical Cyclone, Dec 2007.
13. L. McHugh, "Pilbara Prospects 2020: Challenges and Threats to Regional Security"; Future Directions International, May 2011.
14. NASA – Tropical Cyclone Lua, available from: [http://www.nasa.gov/mission\\_pages/hurricanes\\_archives/2012/h2012\\_Lua.html](http://www.nasa.gov/mission_pages/hurricanes_archives/2012/h2012_Lua.html).
15. Town of Port Hedland, Fire and Emergency Services Authority (FESA) WA, Bureau of Meteorology, "Cyclone and You – Be Award, Be Prepared", 2011, available from" <http://www.porthedland.wa.gov.au/community/cyclonebooklet2011>.

# Dr. Kazumasa Ito, Japan



## Extraordinary Flood Management Project in the Tokyo Metropolitan Area

CTI Engineering Co., LTD

E-mail: [k-ito@ctie.co.jp](mailto:k-ito@ctie.co.jp)

### ABSTRACT

Tokyo Metropolitan District has faced high risks of flooding, especially inundation disasters because concentrating population in urban areas and expanding of urbanization exceed progressively beyond flood control Facilities.

This paper mentioned details of function and effectiveness of comprehensive flood control system and underground rivers in Tokyo Metropolitan area thought projects in Kanda River and Metropolitan Outfall Channels.

## 1 INTRODUCTION

In Japan, urban flood disasters have occurred frequently not only in major big cities but also in local cities postwar high economic growth. Characteristics of urban flooding disasters are: 1) outage of power, gas and water, 2) submergence of basement and underground mall, 3) water-damaged cars, 4) congestion of telephone, 5) run out of wastes. There are several causes of urban flooding disasters: 1) reduction of fields of rice and marshes associated with urbanization, 2) development of hills and mountain forests, 3) sewage improvement, 4) ground subsidence caused by intake of ground water. Increasing of runoff is affected by decreasing the soil-percolation capacity and retarding function of lands.

There are three methods to prevent urban flood disaster; water way management, basin management and flood-proof improvement. The examples of water way management are; underground diversion aqueducts, super broad levee with multiple functions.

Basin management is methods of retaining, retarding and storing water. The examples of basin management are; flood control reservoir, multiple flood-control reservoir. Other method of storing storm water is to store in each housing and apartment. River-basin storage and infiltration projects, such as infiltration trench, leaching pit and water permeable paving are promoting.

Strengthening of infiltration is building high-floored houses, improving underground facilities, such as equipped with waterproof materials, watertight doors, pump drainage, and maintaining water resistance of lifeline.

This article introduced the most effective examples of underground diversion aqueducts of which are methods, structure and effectiveness. The examples of underground rivers are Kanda Underground River and Flood way in the area surrounding the metropolitan district.

## 2 OVERVIEW

### 2.1 Underground river

An underground river is different from a tunnel river which runs through tunnels under mountains. The underground river is an artificial water channel which runs underground of public buildings.

The underground river is two types: One is open channel; the other is penstock.

Therefore it is difficult to broaden rivers in urban areas, several underground rivers are constructed in urban areas, such as Metropolitan Outer waste channel, which is constructed 50 meters deep.

Underground rivers are different from existing rivers of which date usually are calculated based on hydraulic model experiments and hydraulic accounting. Designing of underground rivers should consider thoroughly not only structure but also hydraulic loss head, inflow, amounts of air entrainment, noise and vibration.

On the other hand, utilization of great deep underground spaces innovate new high-tech technologies. For instance, those new technologies which were utilized in Metropolitan, Flood way in the area surrounding the metropolitan district, such as cast-in-site diaphragm wall (140m deep) and shield tunnel in Loop Line seventh (13.7m in it's external diameter) are the largest around the world.

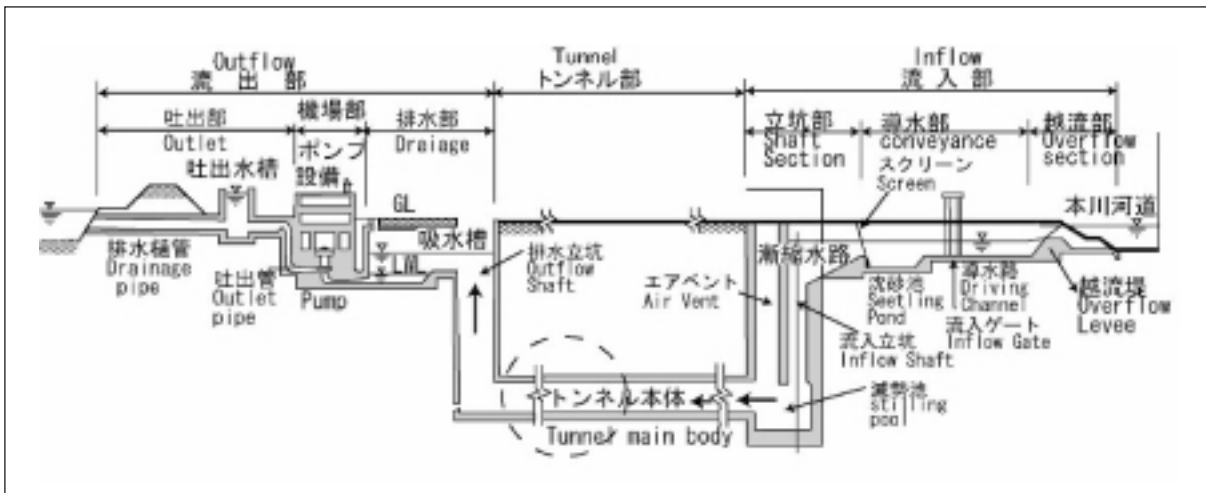

Figure 1 Outline of Underground River

## 2.2 Kanda River

The name of Kanda River has been changed several times.

Kanda River had several names by parts: the headwater of the river, which is from Inokasira Pond, the reservoir of the river, to the confluence of Myousyouji River at Ochiai, approximately 15.4km, is called Inokashira River and Kanda service water; the middle reach of the river, from Ochiai to Funagawara Bridge, approximately 5.1 km, is called Edo River; and the tail reach of the river, from Funagawara Bridge to Sumida River, approximately 4.1km, is called Kanda River.

Those names of the river had been used for long time until the Act of the River Law was enforced in 1964. The entire river started to be called as Kanda River.

The basin of Kanda River occurs frequently flood disasters after rain because capacity of infiltration and storage in basin has been decreased by rapid growth of urbanization.

Nature-friendly river work has produced open access to rivers for neighbors, people-friendly river environment, protecting biodiverse habitat and safety to community.

Objectives of Kanda River Improvement Project are; 1) to reach desirable level of flood control by equipped with revetments and sewerage system to prevent flooding which has occurred every three years; 2) to advance comprehensive flood management by constructing underground compensating reservoirs and runoff control facilities to prepare for heavy rain which has happened every 15 years; 3) to promote river development based on characteristics of the regions.

There are several ongoing projects which are to construct underground river in middle reach of Kanda River as utilized reservoirs to be capable to deal with 50mm per hour of rain water.

The project is to construct a tunnel between Kanda River and Zenpukuji River under the Loop Line Seventh which is 4.5 km-long and 12.5 m-bore diameter and has capacity of storing flood discharge about 54 hundred thousand cubic meters. The tunnel which prevents flooding lower reach of the river is capable to drain away approximately 50mm per hour of rainwater.

## 2.3 Flood Control Channel

Flood way in the area surrounding the metropolitan district was constructed to minimized flood damages of northern part of metropolitan area, where are running several small rivers, such as Naka River and Ayase River. The tunnel takes flood discharge from Naka River and other small rivers then discharges quickly into Edo River.

The waterway tunnel, which is 50m in depth and 6.3km long, is the most powerful and biggest facility for preventing flooding.

The project of Flood way in the area surrounding the metropolitan district is to construct huge tunnels which structures are 25 – 32 m in diameter, five 65m deep shafts, 10.6m in bore diameter and 6.3 km length of total extension.

It will be the largest underground facility for flood prevention around the world. Overflow of the rivers is withdrawn from shafts to the underground tunnel, then it is drawn off to Edo River by four jet pumps which are used gas turbines the same as jet planes.

Its drainability is 200 cubic meters per second which is capable to drain out water equivalent to approximately 25 meter pool of water per second.

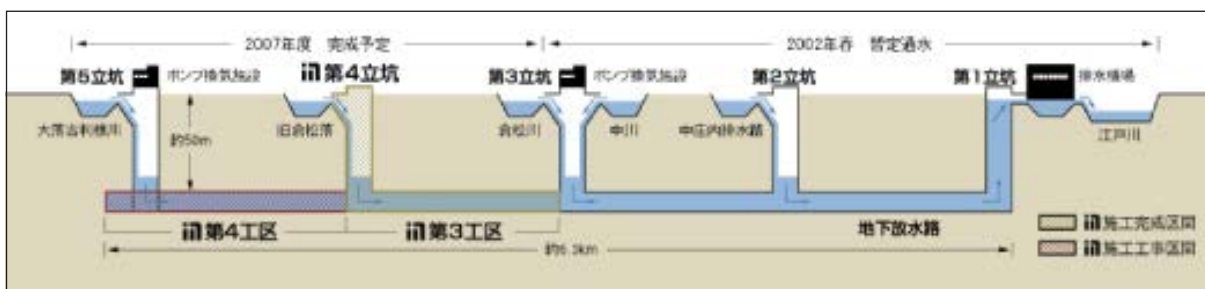

Figure 2 Image of longitudinal sectional view

### 3 KANDA UNDERGROUND RIVER PROJECT

Kanda Underground River Project is to construct a huge tunnel under the Loop Line Seventh which is 4.5 km-long and 12.5 m in diameter for storing approximately 540 hundreds cubic meters of flood water from Kanda River and Zenpukuji River.

The underground river will be able to deal with 50mm of rainfall per hour, and suggest the importance of river improvement project in upper stream of the river.



Figure 3 Location of Kanda Underground River Project



### 3.1 Outline of the project

The project was composed with two phases: the red line is the first phase and the blue line is the second phase which is shown on the figure. Because it constructed 4.5 km of tunnel and . The first phase was

#### 3.1.1 The first phase

The first phase constructs the 2.0 km-long tunnel to store storm water from Kanda River and the intake facility to take water. The project has started in 1986 and completed in 1996. These facilities have been utilized as storm-water reservoir for flood control since April in 1994.

The project has improved safety for flooding

#### 3.1.2 The second phase

The second phase constructs the 2.5 km-long and 12.5 m diameter tunnel to store 300,000 cubic meter of storm water from Zenpukuji River and the intake facility to take water.

Both intake facilities in Zenpukuji River and Myousyouji River which construct shafts and tunnels have started in 1990 and completed in 2005.

#### 3.1.3 Effects

The project has been shown effectiveness to decrease flood damage. Compared with the level of maximum rainfall per hour and the number of submerged houses around completion of underground river project, the number of submerged houses has been decreased since operation of underground reservoir in Kanda River and Loop Line had started in 1997.

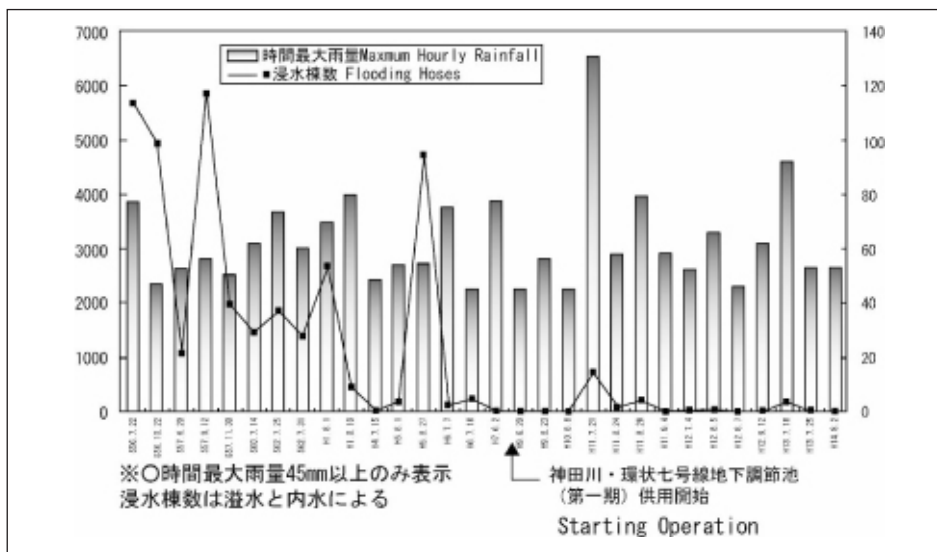

Figure 4 Transition of damage of flooding in Kanda River

## 4 THE FLOOD WAY CONSTRUCTION PROJECT IN THE AREA SURROUNDING THE METROPOLITAN DISTRICT

The Flood Way in the area surrounding the Metropolitan District is the huge flood prevention facility where constructs 50m below ground under Route 16 in between Kasukabe City and Showa Town in Eastern Saitama Prefecture.

The Flood Way is composed with five shafts which are 25 – 32 m in diameter and 65 m in deep and huge tunnel which is 10.6 m in diameter and 6.3km-long.

This facility is the largest underground flood control facility around the world.

Overflow of the rivers is withdrawn from shafts to the underground tunnel, then it is drawn off to Edo River by four jet pumps which are used gas turbines the same as jet planes.

There are four gas turbines which are capable to drain flood water out 200m<sup>3</sup> per second which is the same as the amount of water in 25m pool.

This mega project which has been started in 1993 has begun to operate partly from the third shaft to Edo River in spring 2002. The rest part of the project has gotten the whole thing finished in 2007.

The completion of the project protects approximately 3.2 million residents in the basin from danger of flooding.

**4.1 Outline of the project**

The Flood Way is located in between Furutone River and Edo River (Figure 4).

The Flood Way, which was constructed in lowland between Edo River, Naka River and O-otoshi furutone River, is the huge drainage facility to drain out flood water to Edo River. When heavy rain happens, the facility withdraws flood water from Naka River, Kuramatu River, O-toshi furutone River and so on and stores it in 10 m in diameter and 6.5 km-long stormwater storage pipe which constructs 50 m below ground.

The amount of collecting water from each river is shown below.

- Naka River: 25 m<sup>3</sup>/s (15 m<sup>3</sup>/s)
- Kuramatu River: 100 m<sup>3</sup>/s (55 m<sup>3</sup>/s)
- O-otoshi furutone River: 85 m<sup>3</sup>/s (35 m<sup>3</sup>/s)

The parenthesis numbers are shown current the amount of collecting water.

The maximum capacity of the facility of draining flood water to Edo River is 200 m<sup>3</sup>/s but the facility drains out flood water 100 m<sup>3</sup>/s.

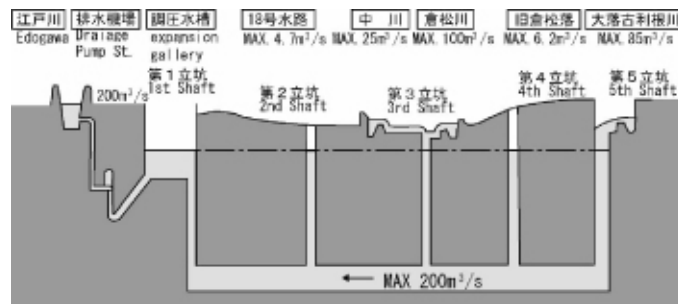
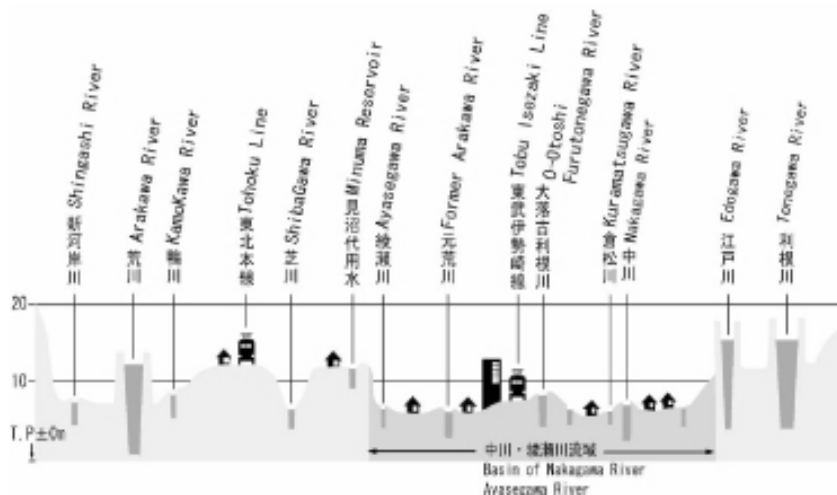

Figure 5 the location of the Flood Way



## 4.2 Outline of the basin

The Naka River basin is located in low wetland and has slow bed slope and small capacity of flow compared with other rivers.

The basin area has been populated and urbanized rapidly because it is located in closed to Tokyo Metropolitan area. The basin has immediate needs to prevent flooding.

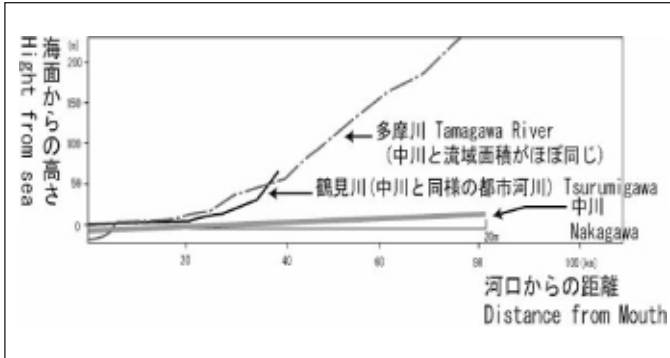

Figure 7 Bed Slope

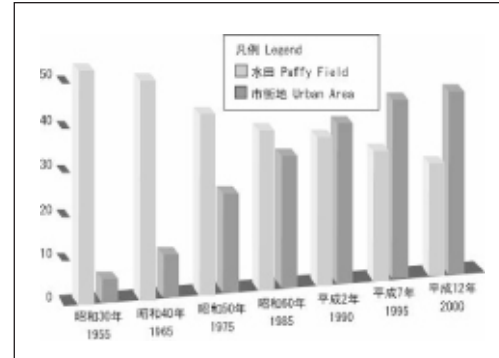

Figure 8 Change of Land Use

## 4.3 The impacts of flood control

The project of constructing Flood Way will reduce risks of 10 year flooding (Figure 9,10).

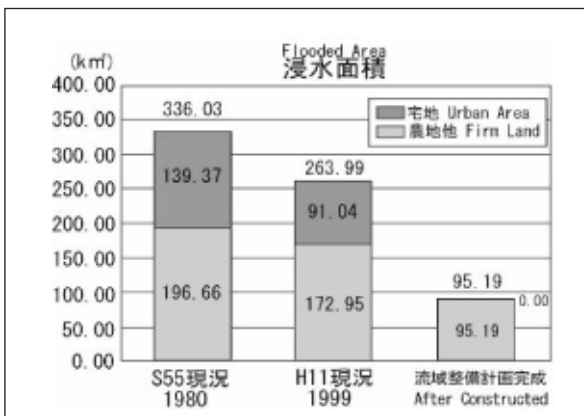

Figure 9 Flooding Area

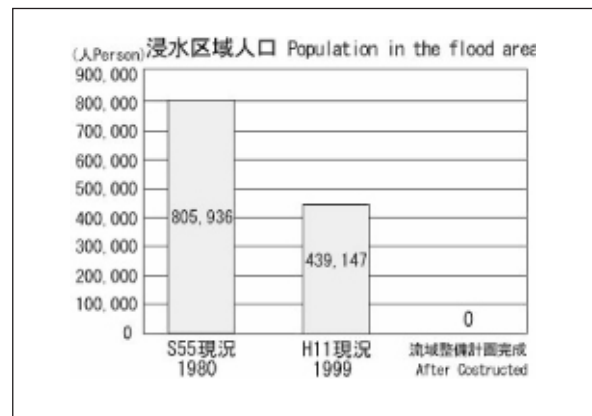

Figure 10 Population in the Flood Area

## 4.4 Outline of the facility

### 4.4.1 The tunnel 50m below ground

Construction of the tunnel 50m below ground was penetrated through alluvial formation to improve performance of shield tunneling method and decrease soil deformability.

The tunnel of Flood Way has 1/5000 slope to improve capability of draining water.

### 4.4.2 Shafts

There are five shafts

The functions of shafts are shown below.

- 1) The place of departure and goal of shield machine
- 2) The place for water intake from each river
- 3) Carry-in entrance for administrative vehicles, ventilating facility and maintenance

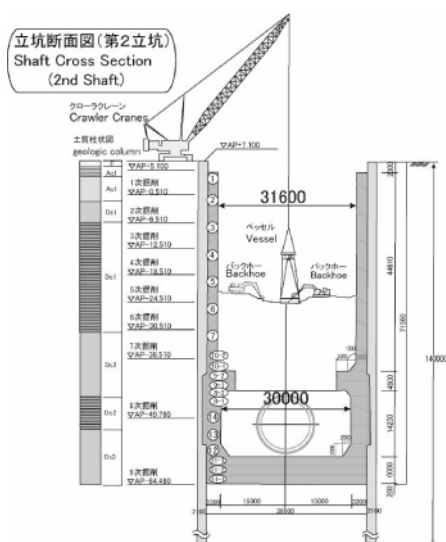

Figure 11. Shaft Cross Section

Table 1. Outline of Shaft

立坑諸元 Outline of Shaft

	上部側壁 Uppersteram Wing wall	下部側壁 Downstream Wing wall	掘削深さ Excavation depth	施工方法 Construction Method
1st 第1立坑	Φ31.6m 壁厚2.5m Wall thickness	Φ30.0m 壁厚3.3m Wall thickness	GL-72.1m	逆巻工法 及び順巻 工法
2nd 第2立坑			GL-71.5m	
3rd 第3立坑			GL-73.7m	Inverted Lining Method/ Normal Lining Method
4th 第4立坑	Φ25.1m 壁厚2.0m Wall thickness	Φ22.5m 壁厚3.3m Wall thickness	GL-69.0m	
5th 第5立坑	Φ15.0m 壁厚2.0m Wall thickness	Φ15.0m 壁厚2.0m Wall thickness	GL-74.5m	自動化オープン ケーソン工法 (SOCS工法) SOCS Method

#### 4.4.3 The facility of inflow

Flooding flows naturally into overflow dams which are constructed in each river depending on fluctuation of water level.

The height of overflow banks is designed to set the same height as surrounding area for fulfilling a function to prevent small and medium sized flooding.

Table.2 Outline of the Inflow

流入諸元 Inflow outline

流入河川 Name of River	流入量 Inflow	越流幅 Overflow width	計画量 Design Flood	流入方式 Inflow System
中川 Nakagawa	25 m <sup>3</sup> /s	17 m	250 m <sup>3</sup> /s	越流堤方式 Overflow Levee Method
倉松川 Kuramatsugawa	100 m <sup>3</sup> /s	53 m	100 m <sup>3</sup> /s	
大落古利根川 O-Otoshi Furu Tone Gawa	85 m <sup>3</sup> /s	33 m	365 m <sup>3</sup> /s	
18号水路 18-Channel	4.7 m <sup>3</sup> /s	4.1 m		
幸松川 KoumatsuGawa	6.2 m <sup>3</sup> /s	9.0 m		

#### 4.4.4 Shield tunnel

Adopted construction method was reverse circulation type shield method for constructing large hole diameter tunnel (10.6m in diameter) in deep underground (50m below ground).

Table 3. Outline of Tunnel

Section	Between	Length (m)	Inside Diameter
Tunnel No.1	No1 Shaft to No2	1,396	10.6
Tunnel No.2	No2 Shaft to No3	1,920	10.6
Tunnel No.3	No3 Shaft to No4	1,384	10.6
Tunnel No.4	No4 Shaft to O-otoshi furutonegawa	1,235	10.6
Connecting Tunnel	No5 Shaft to No4 TN	380	6.5

#### 4.4.5 Outcomes after operation

It was 199mm of heavy rainfall by hitting typhoon in October 2004.

The facility helped to reduce dramatically flooded area by controlling 6.7 million m<sup>3</sup> of flood water.

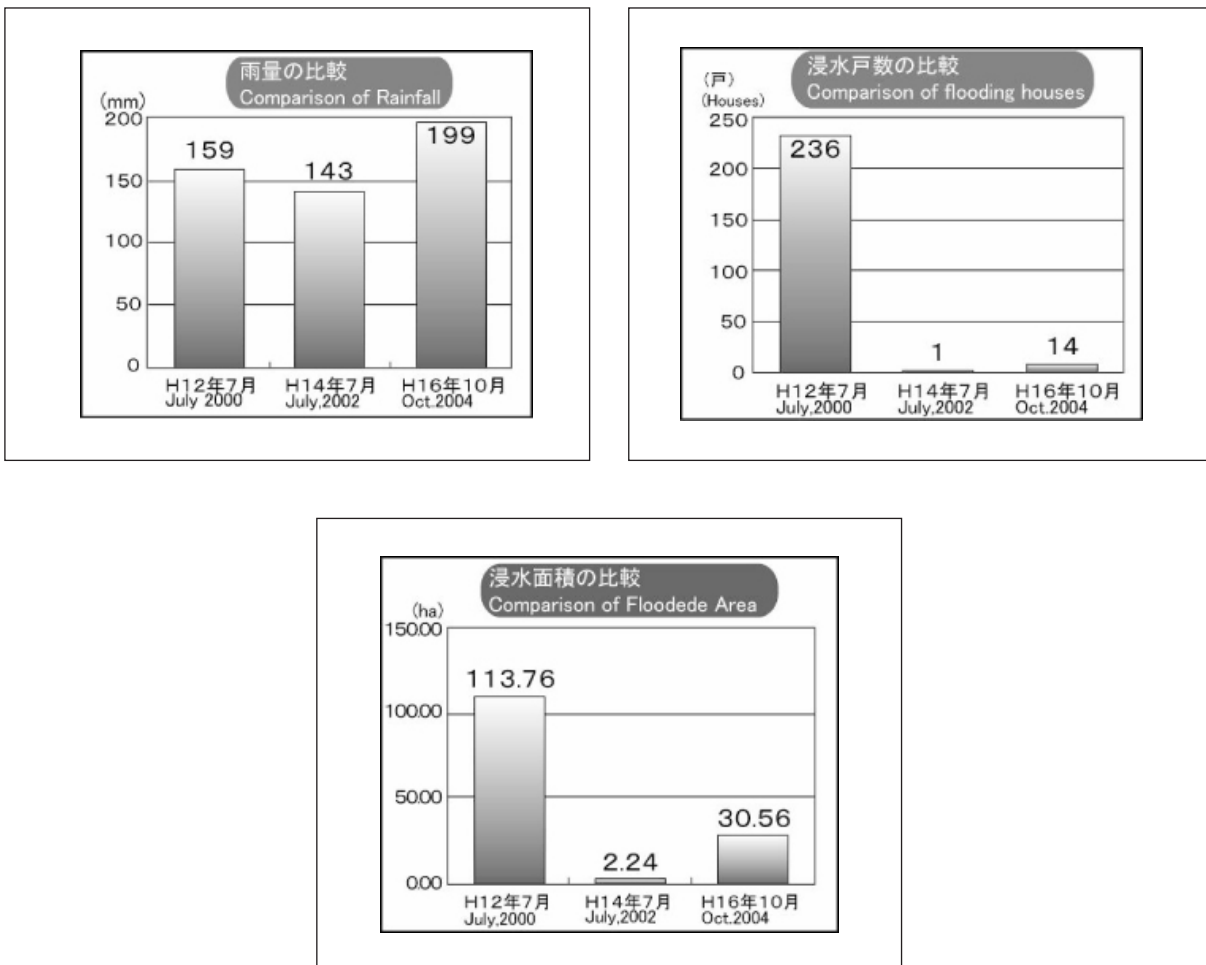

Figure12. Comparison of Rainfall, Flooding Houses, Flooding Area

## CONCLUSION

Flood control in urban area is adopted several methods which are to utilize flood control facilities, such as detention reservoirs, dams and river channels and to adjust flow totally in entire river basin.

Flood control has several difficulties, such as recently, flooding which exceeds estimation has occurred and urban areas where have difficulty to construct flood control facilities. Huge underground reservoirs which store flood water temporary show effectiveness to prevent flooding in those cases.

Kanda River basin, where runs through metropolitan area, is populated rapidly and developed housing sites along the river, therefore it has difficulties to adjust flow in entire river basin and to get enough space to construct reservoir. Construction of huge underground reservoir resolves those problems.

There are several ongoing projects in Osaka (Naniwa Flood Way) and Nagoya (Wakamiya Avenue underground reservoir) right now.

### (1) River channel

Flood prevention by diversion aqueducts

- underground diversion aqueducts in Kanda River, Neya River and Underground River in Loop Line Seventh
- Super Reeve in Yodo River, Edo River and Neya River, under planning
- pumping drainage

### 2) Basin action

Storing and retarding flood water

- Underground reservoir in Hirano River underground reservoir in Osaka and Wakamiya Avenue reservoir in Nagoya
- Multiple reservoir in Neya River multiple reservoir and First reservoir in Myousyouji River Storing rainfall
- Storing rainfall in each resident and apartment infiltration
- infiltration trench, leaching pit and water permeable paving Sewerage system

### (3) Reinforcement of water resistance

High-floored residents, improvement of underground facilities (equipped with watertight doors, waterproof boards, pumping discharge) Improvement life line

Combined these techniques will improve safety for preventing flooding.

### REFERENCES

Ministry of Land, Infrastructure, Transport and Tourism. "Flood Way Construction Project n the Area Surrounding the Metropolitan District."

**Assist. Prof.  
Dr. Stanislav Lenart<sup>(1)</sup>,  
Slovenia  
Fumio Tatsuoka<sup>(2)</sup>, Junichi Koseki<sup>(3)</sup>,  
Japan**



**Use of Reinforced Soil as a Natural Disaster  
Countermeasure**

<sup>(1)</sup> Slovenian National Building and Civil Engineering Institute (ZAG), Ljubljana, Slovenia (formerly IIS, The University of Tokyo)

<sup>(2)</sup> Tokyo University of Science, Chiba, Japan

<sup>(3)</sup> Institute of Industrial Science (IIS), University of Tokyo, Tokyo, Japan

E-mail: [stanislav.lenart@zag.si](mailto:stanislav.lenart@zag.si)

**ABSTRACT**

The collapse of geotechnical structures during natural catastrophes caused by extreme weather conditions and destructive seismic events might cause enormous damage and loss of human lives. Thus their performance based design becomes essential. The importance of large deformation capacity and erosion resistance for geotechnical structures not fully to collapse during extreme events was demonstrated by case histories from past catastrophic events. These are characteristics of reinforced soil (RS), which use in construction of retaining walls and bridge abutments is presented in the paper. Although it is not a new techniques, recent studies gave new knowledge on its optimal use. RS geotechnical structures performed also very well during 2011 the Great East Japan Earthquake Disaster and in some case histories also proved good resistance on tsunami loadings.

## 1. INTRODUCTION

A combination of two engineering disciplines, geotechnical and structural engineering, led to soil reinforcement – a technology known already in faraway past. Civilizations in past used local materials to construct their buildings and engineering structures. As the most wide accessible material, local soil was used as building material in different cases. The tensile strength of soil is relatively low so it is not able allways to transfer all forces arising in structure when it is loaded. Man has realized for a long time ago that tensile forces created in that case can be transferred successful by using some other materials, e.g. wooden rods, straw etc., as a tensile reinforcing element. Thus inclusions have been used to improve soil. One of the oldest proves for the use of such reinforced soil is Chinese Great Wall, where tamped earth with added timber, straw etc. was used in some sections more than 200 years B.C.. Many primitive people used sticks and branches to reinforce mud dwelling. Some other early examples of manmade soil reinforcement include dikes of earth and tree branches and wooden pegs used for erosion and landslide control, which have been used worldwide. Use of plant roots to stabilize land slopes is also wide spreaded. [1]

Modern use of soil reinforcing for retaining wall construction was pioneered by a French architect and engineer Henri Vidal in the early 1960s [2]. The patent for the reinforced earth concept («La Terre Armee») was filed in 1963. The first structure of this kind was build in Pragne (France) in the same year [3]. The concept is based on use of reinforcing strips connected to discrete concrete panels. High internal friction, generated between granular fill and embedded reinforcing strips, allows the transfer of stress from the soil into the strips. Development of polymer geosynthetics, geogrids (more suitable for granular and non-cohesive materials) and woven geotextile (better for fine-grained and cohesive soils), enabled the development of several advanced types of permanent geosynthetic-reinforced soil (GRS) retaining wall allowing a limited amount of deformation, including the one having staged-constructed full-height rigid (FHR) facing (Tatsuoka et al. [4]). Although the soil reinforcement technology has been primarily used for retaining structures with nearly vertical walls, it also enables transfer of tensile forces in several other geotechnical applications, such as steep-sloped embankments, embankments on very soft soil etc.

The effect of reinforcement upon deformation of granular soil is typically seen from Fig. 1. Two specimens of the same granular material with the same dry density were tested in strain controled drained triaxial compression at confining pressure 25 kPa [5]. A large difference in the strength charecteristics can be observed. The first part of stress-strain curve up to deviatoric stress approximately 300 kPa is nearly the same with reinforced and unreinforced sample. However, the second part differs drastically. Even strains at which the strength of unreinforced sample decreases, the deviatoric stress in the reinforced specimen is still noticeably increasing. It is obvious that the reinforcement starts playing its role in the second part of loading.

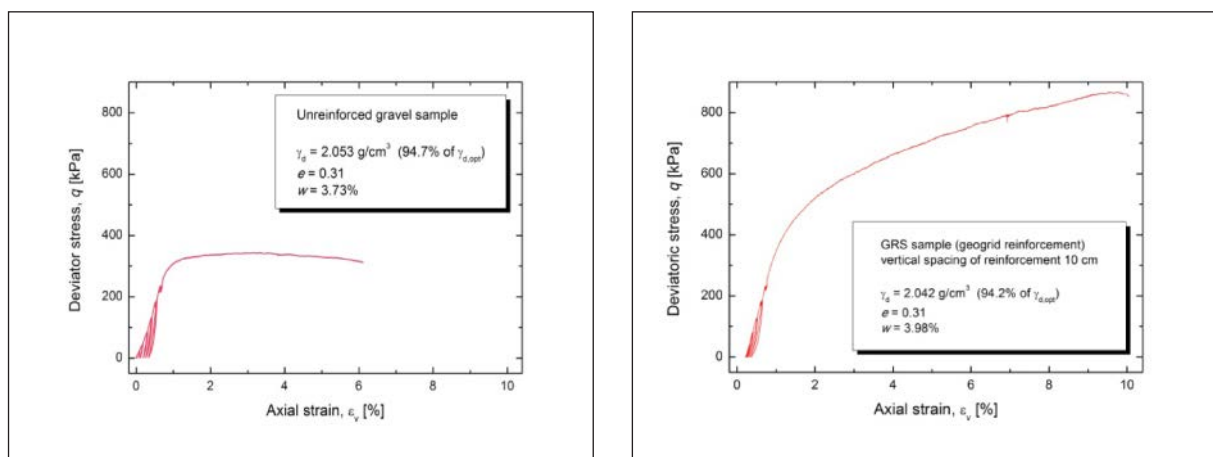

Fig. 1: Drained triaxial compression test with (a) unreinforced and (b) reinforced granular sample



A large deformation capacity without exhibiting collapse is crucial to prevent the collapse of geotechnical structures during extreme events, like earthquakes etc. Besides, floods with consequent washing away of soil particles from the surface is one of the most dangerous impacts on geotechnical structures. Use of erosion control geocomposites installed on the surface of threatened slopes is well known already for a long time [6]. Some case histories from recent extreme events, like tsunami during 2011 the Great East Japan Earthquake Disaster, proved very high erosion resistance of reinforced soil as well.

## 2. TYPICAL GEOTECHNICAL DAMAGE CASES CAUSED BY NATURAL DISASTERS

### 2.1 Past earthquakes and floods

The United Nation Report [7] presents very uneven geographic distribution of disaster risk. For hazards of a similar severity, more developed countries generally experience lower mortality but higher economic losses than poorer countries. Anyway, one can easily understand that geotechnical damage due to natural disasters takes place everywhere, but can be successfully limited if a sufficient knowledge is used in the geotechnical design. As presence of water has enormous effect upon the deformation behaviour of soil, heavy seasonal rainfalls seems one of the most frequent reasons for geotechnical damage. Although tropical cyclones in Asia are most highlighted events of this kind, central Europe has suffered from floods and their consequences often in the last decade as well. Fig. 2 shows collapsed railway embankment in Zagorje, Slovenia, after rainfall in September 2010. The embankment slope became unstable due to heavy precipitation and scouring in the embankment toe. Remediation work was done by conventional gravity type of retaining wall. On the other hand, experiences from elsewhere [8, 12] prove that more cost-effective and resilient types of remediations can be done by geosynthetic reinforced soil (GRS) retaining walls (RW) (Fig. 3).

Reconstruction of soil structures with steep slopes damaged by floods or earthquakes in Japan is more and more often done by GRS RW having staged-constructed full-height rigid (FHR) facing during the last two decades [4, 9]. Tatsuoka et al. [9] reported a case of collapse of long gravity-type RW at seashore facing the Pacific Ocean in Kanagawa Prefecture, southwest of Tokyo. Failure was triggered by strong ocean waves during typhoon in summer 2007 caused scouring in the supporting ground, which resulted in failure of RW for a length of about 1.5 km. The wall was reconstructed to GRS RW with FHR facing. The advantage of FHR facing is a strong resistance against sea wave actions. As the face of RW »hang« on the GRS, it could be stable even if the supporting ground is scoured to some extent. The technology of GRS RW with FHR facing is described later in this paper.



Fig. 2: Railway embankment that failed by rainfall and flood in September 2010 in Zagorje, Slovenia



Fig. 3: Reconstruction works of railway embankment failure in Kyushu in 1991 by GRS RW technology [8]

Sensitivity to scouring is much higher in case of GRS RW with discrete panel facing. A geotextile reinforced retaining structure with discrete panel facings was built as a part of the abutment for concrete highway bridge crossing Mucambo River in Brasil [10]. A severe damage was caused by flood of the river, which caused the erosion of the fill material at the base of the reinforced mass. This led to settlements of the structure with a collapse of several facing units. Despite of severe damage, flexible geotextile reinforced structure sustained large differential settlements and allowed traffic on the bridge with only some repair works in the asphalt layer [10].

An advantage of high flexibility and ductility of GRS RW has been demonstrated very well also during the Kobe Earthquake in 1995 [4, 11]. Gravity type RW at Ishiyagawa site collapsed during the earthquake (Fig. 4a), while similar size GRS RW with stage-constructed FHR facing at Tanata site passed the event with only minor deformations (Fig. 4b). During subsequent reconstructions, most of of damaged conventional type RWs were changed to GRS RWs of this type. The latter also totally replaced gravity type and cantilever type RC RWs in new construction of high-speed train lines nowadays in Japan.

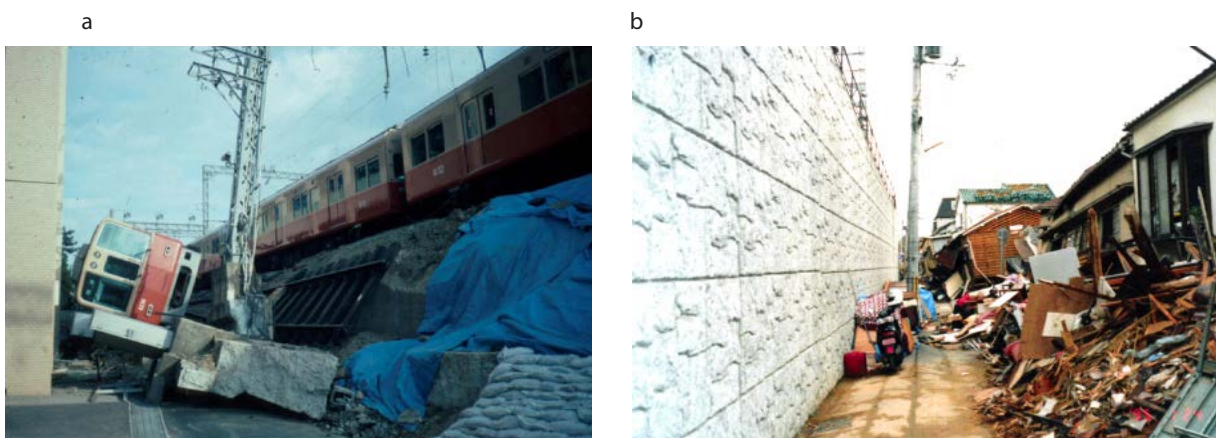

Fig. 4: Difference in behaviour of RWs during the 1995 Kobe Earthquake;  
(a) failure of gravity type RW at Ishiyagawa site;  
and (b) high performance of GRS RW having FHR facing at Tanata site [4, 11]

## 2.1 2011 the Great East Japan Earthquake Disaster

On March 11th, 2011, an extremely destructive earthquake of magnitude  $M_w=9.0$  affected east part of Japan. A long duration time of strong shaking made the geotechnical damage severer. The liquefaction of subsoil and tsunami disaster were most prominent, but also a huge number of river levees, road embankments and residential development fills were severely damaged [13]. Fig. 5 shows cracks occurred on a dike of Tone river. Apparently part of the levee suffered from slope failure during the seismic loading. Such events were frequently initiated by liquefaction of subsoil layers. Liquefaction induced lateral flow, like the one shown on Fig. 6, was also observed in Tone river basin.



Fig. 5: Cracks on Tone river levee, Kitasoma district, Ibaraki prefecture



Fig. 6: Lateral flow of level ground facing at chanel in Katori city, Chiba prefecture

While more or less sloped ground suffered damage due to additional loading by inertial forces caused by earthquake or due to the loss of bearing capacity of supporting ground, geotechnical structures were suffered also by surface erosion of over-flowing current of tsunami. There were numerous road and railway bridges which approach fills behind the abutment were washed away by tsunami. The unreinforced backfill has very low resistance against erosion by over-flow water current and thus typical damages as seen from Fig. 7 were very frequently observed along the eastern coast of Tohoku region, which was affected by tsunami. Moreover it is assumed [13] that overtopping by tsunami arrival wave caused heavy erosion and loss of backfill soil behind coastal levees and sea walls. Tsunami barriers were lost therefore and severe flooding was caused. Thus backfill soil erosion caused enormous damage and loss of human lives.



Fig. 7: Seaside view at Yonedagawa bridge in Noda village after tsunami affect, Iwate prefecture

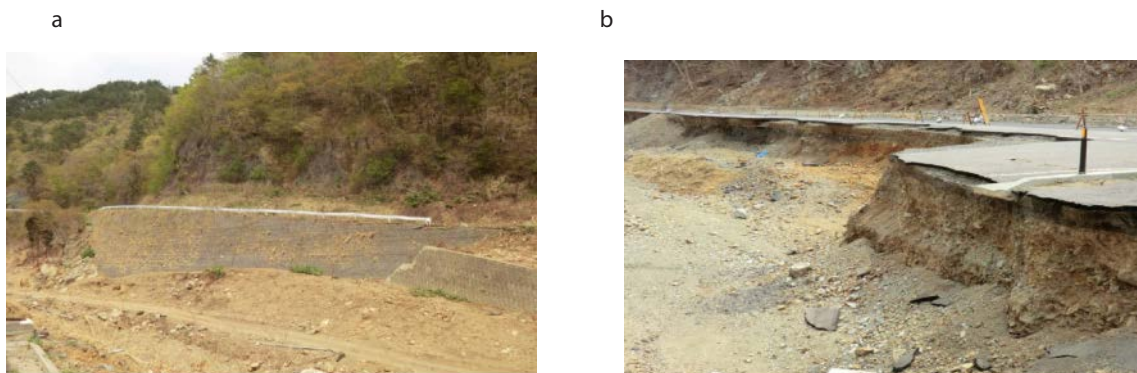

Fig. 8: Tsunami caused road embankment erosion in case of a) reinforced soil retaining wall supporting a road and (b) unreinforced soil road embankment in Tanohata village, Iwate prefecture

It was proven by several cases in tsunami affected area that soil reinforcing can significantly improve resistance of backfill soil against erosion and washing away. One of the evidences is shown in Fig. 8, where two road embankment sections near Tsukue beach, Tanohata village in Iwate prefecture are presented. They were affected by the tsunami loadings. It can be seen that reinforced soil retaining wall supporting a road has passed the tsunami without any serious damage, while a nearby road section with unreinforced soil embankment was almost completely washed away.

### 3. GRS RETAINING WALLS

#### 3.1 Problems with conventional type of retaining walls

Numerous conventional type retaining walls (RW) collapsed during past earthquakes, heavy rains and floods. These collapse cases usually resulted from inappropriate seismic design, or occurrence of unexpected loading cases (such as additional unstable soil mass behind the wall, rise of ground water level etc.), or structural damage of RW (can be caused also by over-flowing flood water). Many road and railway embankments retained by gravity type of RWs along rivers collapsed by floods and storms, usually triggered by over-turning failure of RW caused by scouring in the supporting ground [9]. This mechanism is illustrated on Fig. 9.

The obvious disadvantage of conventional type of RW (especially gravity type) in case of seismic loading is its huge mass. Besides, the construction of conventional type of RW needs many construction steps with a long construction period, temporary structures and heavy construction machines. The construction cost increases by use of pile foundation when supporting ground is not strong enough. Therefore, the construction of conventional type RWs is usually not cost-effective. An environmental impact (total emission of CO<sub>2</sub>) is large as well.

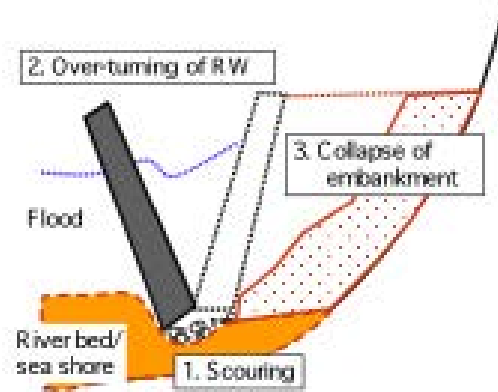

Fig. 9: Collapse of conventional type of RW caused by scouring [9]

### 3.2 GRS staged construction

In contrast to the conventional type RWs, the construction of geosynthetic-reinforced soil (GRS) RW is much less complicated with less construction steps, a shorter construction period and less temporary structures (such as anchors, sheet piles and formworks) needed. GRS RW normally use no pile foundation. It can be constructed faster by means of lighter construction machines and even with possible use of local backfill material [4]. Thus it is much more cost-effective and environmental friendly compared to conventional type RWs.

The most important difference in the mechanism between conventional type RWs and GRS RW is the way how they carry load (earth pressure). We deal with a conventional type cantilever structure as a cantilever structure that resists large forces due to earth pressure activated on the facing wall. It results in large overturning moment and large lateral load at the bottom of the facing. Consequently, massive and strong facing wall is needed, very often with a pile foundation due to the stress concentration at the bottom of the facing.

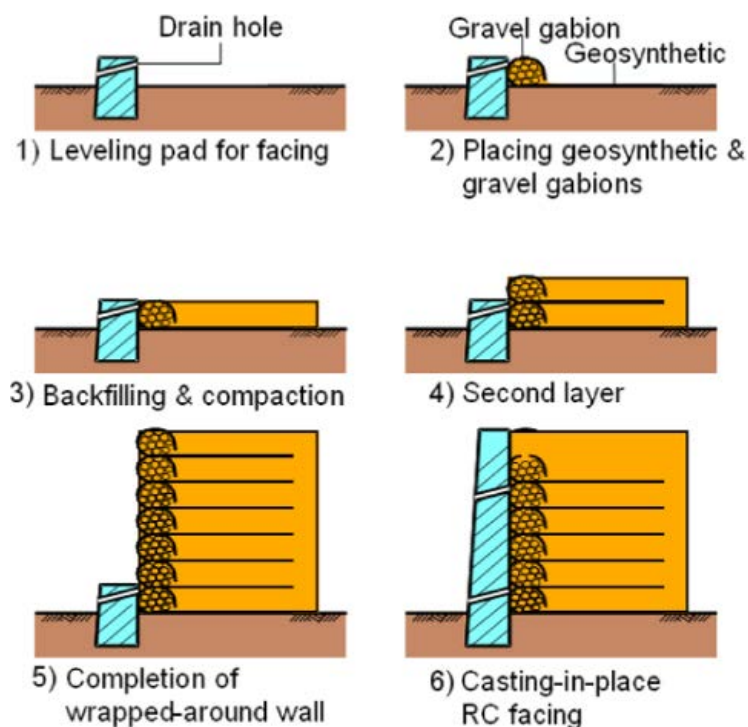

Fig. 10: Staged construction procedure of GRS RW [4]

GRS is a mass built with alternating layers of compacted backfill material (soil) and closely spaced reinforcement layers [1]. Due to the interaction between soil and the reinforcement layers with high tensile strength of the latter, GRS RWs are internally stable. After full-scale GRS experiments with wrapped-around wall face [14], Tatsuoka et al. concluded that stiff and stable wall face is essential for good performance (i.e., high stability and small residual deformation) of GRS RW. They ensured the good performance of wall during and after completion also by placing soil bags (gabions) at the shoulder of each soil layer during construction process. The soil bags function as a temporary but stable facing structure during construction, resisting against earth pressure generated by compaction works and further backfilling at higher levels. Fig. 10 presents the procedure of staged construction of GRS RW with the use of soil bags as temporary facing. Relatively large earth pressure behind the soil bags is similar to the active earth pressure that develops in the unreinforced backfill [9]. It results in high confining pressure in the active zone and thus enables high stiffness and strength of active zone. Furthermore, by achieving high connection strength between reinforcement layers and facing [15], the full-height rigid (FHR) facing wall can behave as a continuous beam loaded by earth pressure and supported by reinforcement layers at many elevations with a small span defined by the vertical spacing of reinforcement (usually 30 cm). Therefore, bending moment and shear stresses in the FHR facing becomes very small (due to small span) and a quite thin facing wall (usually 30 cm-thick) with only slight steel reinforcement is needed. Although small forces are mobilized inside the facing structure, some stiffness of facing is needed to develop the mechanism described above.

### 3.3 FHR facing

When the facing for a GRS retaining wall is constructed by using discrete panels, which are usually constructed at the same time as reinforced backfill, some deformation of the reinforced backfill and supporting ground might have developed until the completion of the wall. Thus it is very difficult to achieve good alignment of the completed wall face. Moreover, any differential settlement between the facing and the backfill during the wall construction might damage the connection between the reinforcement and the facing. As explained in previous section, firm connection between the reinforcement and the facing is required to achieve high stiffness and strength of the backfill immediately behind the wall face. Therefore, Tatsuoka et al. [4] suggested the construction of full-height rigid (FHR) facing by casting in place lightly steel-reinforced concrete layer directly on the wall face consisting of sand bags wrapped-around with geosynthetic reinforcement at the shoulder of each soil layer after the potential deformation of the backfill and supporting ground has taken place.

The staged construction of GRS RW with final casting in place of full-height rigid facing is presented in Fig. 10. Due to all advantages as mentioned above, GRS RW with FHR facing has totally replaced conventional RW types (i.e. gravity type and cantilever type RC RW) and steel strip-reinforced soil RWs with discrete panel facing for new construction of RW for Japan railways [9]. High seismic stability was validated by good performance during several strong earthquakes, among others also 2011 the Great East Japan Earthquake Disaster. High cost effectiveness of staged construction of GRS with FHR facing was proven by the total wall length in Japan of more than 135 km (as of June 2012, [9]).

The wall face of this type of GRS RW is protected by FHR facing, which is firmly connected to reinforcement layers in GRS backfill. As mentioned already above in this paper, GRS RW with FHR facing is very stable against scouring in the supporting ground. It is particularly important that even when supporting ground is scoured, the major part of the backfill can survive. The behaviour of GRS RW with FHR facing during such an event is illustrated in Fig. 11.



Fig. 11: Good performance of GRS RW with FHR facing in case of scouring [9]

## 4. GRS INTEGRAL BRIDGE

### 4.1 Problems with conventional type of bridges

A conventional type short span bridge (approximately up to 20 m) usually consist of a single simple-supported girder supported by a pair of abutments via fixed or hinged movable bearings. If longer span is to be reached, multiple simple-supported girders additionally supported by piers are used. The approach fill is usually unreinforced backfill often combined by a approach slab for smoother transition. The abutment may be made of unreinforced concrete, masonry or reinforced concrete.

Due to the fact that the abutment is a cantilever type structure, the earth pressure induces large lateral forces and overturning moment at the abutment, in the same way as conventional type RWs. As in the case of RW, pile foundation becomes necessary in case of soft ground to prevent any small movement of the abutment caused by the earth pressure or settlement. Obviously, this kind of structures are very costly. The cost even increases by long-term maintenance of bearings and the construction of transition zone. Within the transition zone (with or without approach slab) behind the abutment, a significant bump may be formed due to long-term settlement of the backfill caused mostly by traffic loads and the one by seismic loads.

To avoid problems with bearings, the girder can be fixed to the abutments to form a frame (so called integral bridge). Although this bridge type is very popular for short spans worldwide (also named box girder type of bridge), it has important drawbacks. As the girder is integrated to the abutments, seasonal thermal expansion and contraction of the girder results in cyclic lateral displacements at the top of the abutments. These cause development of high passive earth pressure on the back of the abutment and large settlements due to active failure in the backfill. So called »dual ratched mechanism« can develop due to the cyclic nature of lateral displacements [8]. On the other hand, to solve problems with the backfill, several bridges were constructed with girder supported via bearings placed on sill beams on the crest of the GRS with FHR [4, 9]. This type of abutment has successfully omitted the development of high earth pressure on the back of the abutment and large settlements in the backfill, but it still has problems due to the use of bearings. The test results [8, 9, 11] helped to understand all those drawbacks and to propose new type of bridge (Fig. 12).

### 4.2 Evolution of GRS integral bridge

It is very rational and meaningful to merge advantages of integral bridge (free from the problems with the use of bearings) and GRS RW bridge (with a high cost-effectiveness, a high seismic stability, good backfill performance etc.). Thus Tatsuoka et al. [8, 9, 16] proposed a new bridge type, called Geosynthetic-Reinforced Soil (GRS) integral bridge. Its evolution is presented in Fig. 12. GRS integral bridge consists of a girder that is rigidly connected (integrated) to a pair of FHR facings and backfill reinforced with geosynthetic layers that are firmly connected to the facings. No bearing for the girder is used.

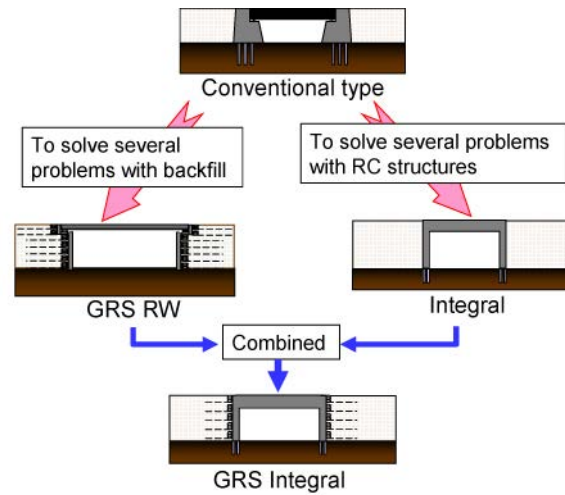
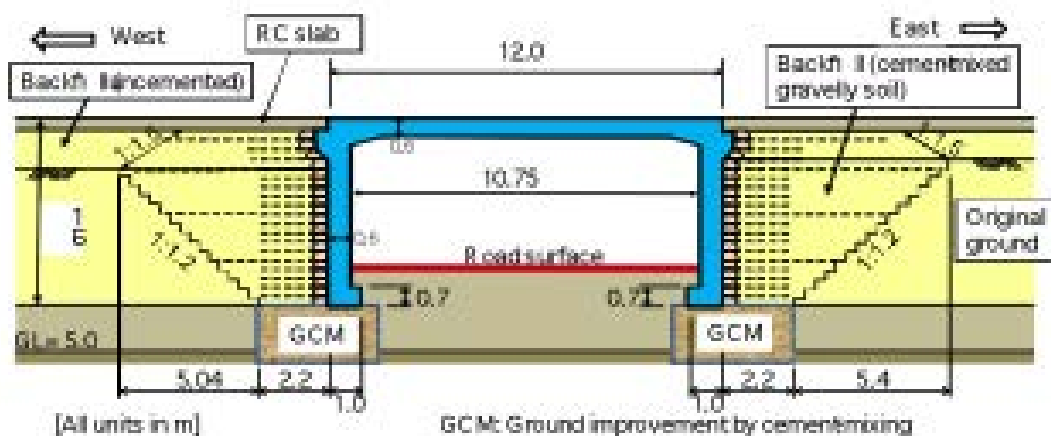

Fig. 12: Development of new bridge type [16]

A pair of GRS walls with FHR is supposed to be constructed in stages, following procedure presented in Fig. 10. After major potential deformation of the backfill and supporting ground has taken place, FHR facings are constructed in the same way as GRS RWs with FHR facing. A girder is then constructed structurally integrated to the top of the facings. The first prototype GRS integral bridge was constructed in 2011 at the south end of Hokkaido (Japan) for a new high-speed Shinkansen train line. The estimated construction costs of the bridge were about a half of the one for box girder type bridge. Fig. 13a shows the structural details, Fig. 13b shows the abutments under construction and Fig. 13c shows the nearly completed bridge.

The damage survey of the 2011 the Great East Japan Earthquake Disaster revealed a low resistance of conventional type single span bridges (girders supported by bearings, unreinforced backfill) against not only seismic loads but also against tsunami forces. Therefore, not only due to the low construction costs but also due to good seismic and tsunami performance, two railway bridges (for Sanriku railway) that fully collapsed by tsunami will be reconstructed to GRS integral bridges. It can be expected that GRS integral bridge type will become dominant in future for construction of roads and railways, in particular those on coastline with possible tsunami occurrence. Also against floods, which brings possible occurrence of scouring, GRS integral bridges are much more stable than conventional type bridges.

a)





b)



c)



Fig. 13: First GRS integral bridge for a new high-speed train line at the south of Hokkaido: a) structural details (the width= 11.7 m); b) during construction (August 2011); and c) nearly completed (August 2012).

## 5. GRS TSUNAMI BARRIER

Tsunami current (like the one caused by the 2011 the Great East Japan Earthquake Disaster) induces very high lateral forces on any kind of coastal dyke. When over-flow happens, additional erosion of downstream slope should be expected if slope is not perfectly protected. Conventional type of coastal dyke usually comprises unreinforced backfill with concrete panel facings covering upstream and downstream slopes and crest that are not anchored in the backfill [9]. As experienced with coastal dykes that fully collapsed by over-flow current of tsunami of the 2011 the Great East Japan Earthquake Disaster, scouring in the ground in front of the downstream slope and uplifting of the concrete facing at the crest of dyke were the two main mechanisms for the beginning of the full collapse. The drawback of tsunami affected the seaside slope by the same mechanism [9]. Even when erosion protection was partly lost, the unreinforced backfill was allowed to flow out from openings and thus initiate rapid erosion.

From the experiences with GRS RW with FHR facing, we know that, in addition to high stability against lateral loads, this kind of structure can also exhibit very good resistance against the scouring in the supporting ground (Fig. 11) and the erosion of the backfill by protecting with facing that is connected to the reinforcement layers. Therefore an improved type of tsunami barrier has been proposed [9], using geogrid-reinforced backfill with continuous lightly steel-reinforced concrete facings that are firmly connected to the reinforcement. Fig. 14 shows some possible derivatives of GRS coastal dykes, which will survive deep over-flow of tsunami current.

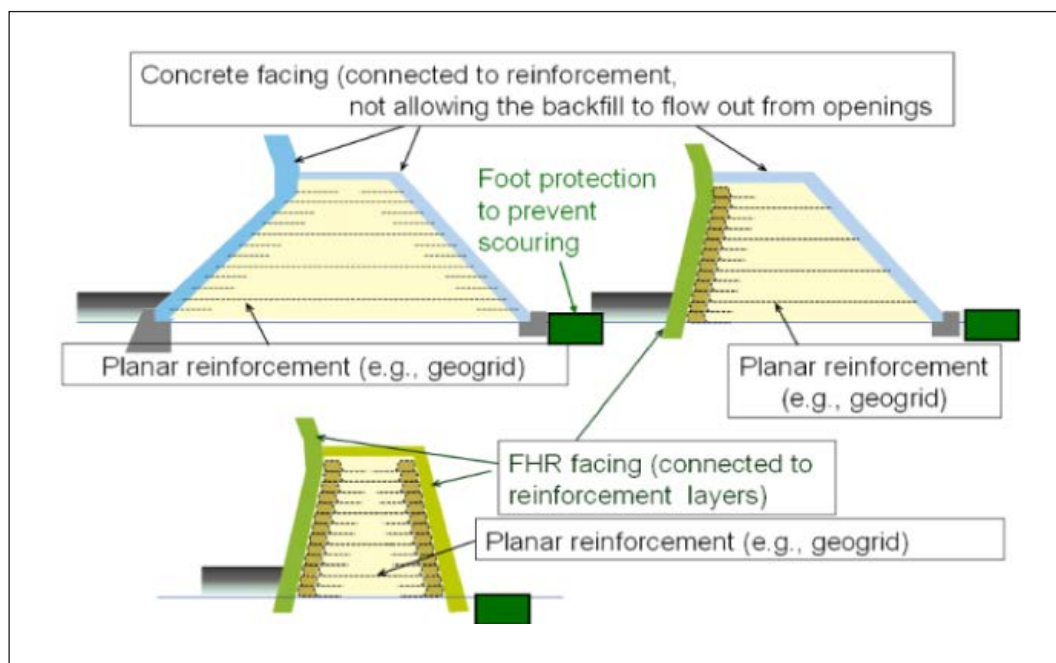

Fig. 14: Proposed GRS coastal dykes as a tsunami barrier [9]

## 6. CONCLUSIONS

Different natural catastrophes caused by extreme weather conditions, which have become severer by climate changes, and destructive seismic events always involves the collapse of geotechnical structures. Their collapse during such an event might cause enormous damage and loss of human lives. Case histories from past catastrophic events demonstrate the importance of erosion resistance and large deformation capacity for geotechnical structures not to fully collapse.

Geosynthetic-reinforced soil retaining walls (GRS RW) having staged-constructed full-height rigid (FHR) facing has been proven as a technology which fulfill all the requirements for safe, durable, cost-effective and environmental friendly geotechnical structure. They have been constructed as important permanent RWs for a total length more than 135 km since 1989 until today in Japan, many for high-speed train lines. A number of embankments and conventional type RWs that collapsed during recent severe earthquakes, heavy rains and floods were reconstructed to GRS RW with FHR facing.

The advantages of this technology have been used also for development of a new type of bridge, called GRS integral bridge. It consists of integral bridge and geosynthetic-reinforced backfill with staged-constructed FHR facing. Many laboratory and field tests and construction of the prototype showed lower cost for construction and maintenance, less damaging effects of seasonal thermal deformation of the girder and higher seismic stability when compared to other types of bridges. If geogrid-reinforced approach fill would have facings on its three sides, higher resistance against erosion of approach fill during heavy rains and floods would be achieved as well. Following the same approach, GRS embankments/dykes with facings connected to the reinforcement have been proposed as high resistance tsunami barriers.

## 7. ACKNOWLEDGEMENTS

Authors sincerely thank researchers from the University of Tokyo, Tokyo University of Science and Railway Technical Research Institute, Japan, for their research work in last two decades to develop the GRS technologies described in this paper.

## REFERENCES

- [1] FHWA (2000). *Mechanically Stabilized Earth Walls and Reinforced Soil Slopes Design and Construction Guidelines*, Federal Highway Administration, FHWA-NHI-00-043
- [2] Wikipedia (2012). Mechanically stabilized earth, [http://en.wikipedia.org/wiki/Mechanically\\_stabilized\\_earth](http://en.wikipedia.org/wiki/Mechanically_stabilized_earth)
- [3] Terre Armee home page (2012), <http://www.terre-armee.com>
- [4] Tatsuoka, F., Tateyama, M., Uchimura, T., and Koseki, J. (1997). Geosynthetic-reinforced soil retaining walls as important permanent structures, *Mercer Lecture, Geosynthetic International*, Vol.4, No.2, 81-136
- [5] Lenart, S., and Koseki, J. (2011). Small to medium range strain stiffness of reinforced gravel, *unpublished yet*
- [6] Koerner, R.M. (1998). *Designing with Geosynthetics*, Fourth Edition, Prentice Hall
- [7] ISDR (2009). *Global Assessment Report on Disaster Risk Reduction*, United Nations, Geneva, Switzerland
- [8] Tatsuoka, F. (2008). Geosynthetic-reinforced soil structure: A cost-effective solution combining two engineering disciplines, *19<sup>th</sup> Nabor Carrillo Lecture*, Mexico
- [9] Tatsuoka, F., Tateyama, M., and Koseki, J. (2012). GRS structures recently developed and constructed for railways and roads in Japan, *2<sup>nd</sup> International Conference on Transportation Geotechnics*, Hokkaido, Japan
- [10] Palmeira, E.M., Fahel, A.R.S. and Campos, L.E.P. (2003). Geotextile Reinforced Abutments on Soft Foundation, *Reinforced Soil Engineering: Advances in Research and Practice*, Merce Dekker
- [11] Tatsuoka, F., Koseki, J., Tateyama, M., Munaf, Y. and Horii, N. (1998). Seismic stability against high seismic loads of geosynthetic-reinforced soil retaining structures, *Keynote Lecture, Proc. 6<sup>th</sup> Int. Conf. on Geosynthetics*, Atlanta, 103-142
- [12] Koseki, J. (2012). Use of geosynthetics to improve seismic performance of earth structures, *Mercer Lecture 2011, Geotextiles and Geomembranes*, 34, 51-68
- [13] Towhata, I. (2011). Geotechnical damage caused by the recent gigantic earthquake in Japan, *3<sup>rd</sup> International Conference on Geotechnical Engineering for Disaster Mitigation and Rehabilitation (GEDMAR)*, Indonesia
- [14] Tatsuoka, F., Tateyama, M., Tamura, Y., and Yamauchi, H. (2000). Lessons from the failure of full-scale models and recent geosynthetic-reinforced soil retaining walls, *Proc. the 2<sup>nd</sup> Asian Geosynthetics Conference, GeoAsia 2000*, Kuala Lumpur, 1, 23-53
- [15] Tatsuoka, F. (1993). Roles of facing rigidity in soil reinforcing, Keynote Lecture, *Proc. Int. Sym. on Earth Reinforcement Practice, IS Kyushu '92 (Ochiai et al., eds)*, Balkema, 2, 831-870
- [16] Tatsuoka, F., Hirakawa, D., Nojiri, M., Aizawa, H., Nishikiori, H., Soma, R., Tateyama, M., and Watanabe, K. (2009). A new type integral bridge comprising geosynthetic-reinforced soil walls, *Geosynthetic International, IS Kyushu 2007 Special Issue*, 16(4), 301-326





## Dr. Yumio Ishii, Japan

### Damages and Evaluation of Investment in Integrated Disaster Risk Management

CTI Engineering Co., LTD

E-mail: [ishii@ctie.co.jp](mailto:ishii@ctie.co.jp)

#### ABSTRACT

The year 2012 marks the 20th anniversary of the Rio Summit, the milestone event where “Sustainable Development” was declared as the universal goal for the human beings. Preventing or reducing disaster risk is the key towards this goal, however, catastrophic disasters have occurred frequently in various regions in recent years, implying insufficient disaster preparedness in the society as the cause. Every disaster is essentially social phenomena regardless of whether it is natural or human induced. From this standpoint, this paper discusses the following two points:

- Firstly, disaster risk should be evaluated not only by direct damage on structures and loss of lives, but also by indirect and unquantifiable damage. Also, equal importance should be placed on structural measures and non-structural measures in a social and integrated manner, with a vision both short-term and long-term perspectives for decades and centuries ahead.
- Secondly, conventional Benefit-Cost method is not appropriate for evaluating the effect of investment for disaster risk management, in particular, where it is related to extreme events such as catastrophic disasters.

These discussions are made on water-related disasters and geographical disasters with a focus on Japan. Please note that human-induced disasters are mostly excluded from discussions in the following sections.

## 1. ROLE OF INFRASTRUCTURE AGAINST DISASTER

### 1.1 Historical Development and Infrastructure

Historically, infrastructure supports prosperity and security of mankind by providing protection against natural disasters. Although the function of infrastructure is not always successful, it has been sustained at present level through long-term investment.

### 1.2 Budget for Infrastructure

There has been hundreds and thousands of victims suffered from earthquakes, tsunamis, and storm surges in Asian countries. Lack of investment for infrastructure development and the resulted insufficiency in structural protection against disasters, despite the fact that the population is concentrated in disaster prone areas, are thought to be the cause for this situation. Out of Asia, the 2005 Hurricane Katrina in the United States is also said to have the same cause.

On the contrary, Japanese experience shows that there was significant damage after the World War II when disaster prevention structures were destroyed and inadequately provided, but the damage was reduced as the investment for disaster prevention was being increased in the following years, which built up the today's prosperity in Japan. The effect of the infrastructure development is clearly shown in the sharp decrease in the number of death in 1960 and onwards. Nevertheless, 6,500 lives were lost in the 1995 Great Hanshin Awaji Earthquake of magnitude 7.3, and 19,000 lives were lost in the 2011 Great East Japan Earthquake of magnitude 9.0. These events have important implication for further investment to be required to prevent such damage.

## 2. DEFINITION OF DISASTER AND DAMAGE

### 2.1 Causes of Disaster

Disasters are roughly classified into natural disasters and human induced disasters by their causes. Natural phenomena which occur with no relation to human activities will not develop into disasters. Therefore, we must recognize all the disasters are social phenomena.

Disasters can be defined as a threat to the safety of the society, but they are generally referred to only those triggered by natural phenomena. However, we should keep in mind that natural phenomena sometimes trigger international conflicts. The Middle East Problem is essentially conflict over water in arid regions, as Mr. Ryutaro HASHIMOTO, the former Prime-Minister of Japan and adviser to UN Secretary General, had once aptly pointed out.

### 2.2 Change of Causes of Disasters

There is another point of view that human power has been increased to such an extent to change natural environment and create the cause of disasters. Vulnerability to disasters has been increased through development activities by human beings, such as reclamation of land, underground spaces, coast and these resulted in changes in ecosystems. Ironically, disasters are the consequence of human activities for own well-being, as they are at the same time amplified disaster risk and climate change impact. Therefore, disaster prevention infrastructure of the modern era should take account not only of the changing nature but also of the society that induces such change.

### 2.3 Increase of Disaster Risk

There is a representative example of Japan, a highly developed society formed onto lands prone to disasters.

The Japanese archipelago consists mostly of steep mountainous areas with very few plains, which take up about only 10% of the total land area. Japan is one of the most earthquake prone nations as it lies at the nexus of the Eurasian plate and the Pacific plate. Climatic hazards such as floods caused by typhoons, storm surges, and landslides occur frequently in almost every year, and extreme weather events take place due to the recent climate change. Over half of population, assets, and infrastructure are concentrated in the

lowlands. Underground spaces beneath the lowlands are also highly utilized in recent years, however, the soil foundation of such area is weak because it is made up either of alluvial plain deposits or reclaimed land areas. Moreover, most part of the lowlands is situated below sea level, inflicting the risk imposed by tsunamis, floods, storm surges, seismic motions, and liquefaction.

### 2.3.1 Climatic Hazard

#### – Floods, Storm Surges, Droughts –

As shown in the IPCC fourth report, increased hazard risk due to global warming has now been universally recognized. It is expected that average temperature in Japan will rise up to 4.7 °C in 100 years time, posing much higher risk of climatic hazards.

In this regard, the probability that has been estimated based on the past records will no longer be valid. For example, the return period which is applied to disaster risk management projects of Japanese rivers are 100 - 200 years for flood control, and 10-year for water supply. There is a concern that such return period will have to be cut short in future. [1]

The flood peak discharge has been raised due to urbanization, and this also poses increased water-related hazard risk. The doubled peak discharge is expected in urban rivers.

### 2.3.2 Geographical Hazard

Taking account of the location of the Japanese archipelago, it is highly likely that more than M9.0 earthquake equivalent to the 2011 Great East Japan Earthquake will occur again in future. In particular, there is high probability for the earthquake in the Nankai Trough situated to the south part of the archipelago, with level 7 quake, over 30m high tsunami, liquefaction, and subsidence and uplift of the ground.

Volcanic eruptions and landslides are also chronic cause of disasters in Japan.

## 3. DEFINITION OF DISASTER AND DAMAGE

Based on the viewpoints described above, classification of disasters has been made as shown below.

### 3.1 Classification by Causes of Disasters

#### i. Natural vs. Human induced Disasters

- Natural (Climatic, Geographical): Weather and Climate, Earthquake, Volcanic Eruption, Landslide, Crustal Movement
- Human induced Disasters: Climate Change, Environment Deterioration, Ground Subsidence by exploitation of groundwater or oil. Human Error, Mal-operation

#### ii. Sudden Onset vs. Creeping Disasters

- Sudden Onset: Earthquake, Tsunami, Liquefaction, Landslide, Volcanic Eruption, Accident of Plant
- Medium Onset: Typhoon, Storm and Tornado, Flood, Tidal Surge
- Creeping: Climate Change, Drought, Ground Subsidence and Sea Level Rise, Pollution of Air and Water, Diseases caused by Pollution

### 3.2 Direct and Indirect Damage

Though the direct and structural damage has been usually recognized as major damage, the indirect and non-structural one is getting severer in recent days. Also, we must remember that damage to not only residents but also commuters, tourists and foreigners in the affected area are extremely increasing due to the recent urbanization and globalization. Concerning the indirect damage, the Government of Japan published the manual of water-related damage study covering indirect damage. [2]

#### 3.2.1 Direct Damage:

There is a broad range of direct damage as classified below. In general, direct damage is evaluated by physical damage on general assets, agricultural products, infrastructure and loss of life.

### Direct Damage

- General Assets: Residential Buildings, Furnishings, Cars, Business Properties (Depreciable assets, Stockpiles), Agricultural and Fishery Assets (Depreciable assets, Stockpiles) , Agricultural products
- Infrastructure
- Business Suspension
- Fatalities
- Evacuees (residents and non-residents including commuters, tourists, foreigners)
- Permanent Evacuation, Relocation
- Cost for Maintaining Business Establishments in Affected Areas (In the case of nuclear plants, several decades are required for decommissioning)

### 3.2.2 Indirect Damage

Indirect damage includes standstill of supply chain by stoppage of materials and commuter transport and information system, paralysis of information network and public administration, loss of business chance, standstill of tourism. In particular, the fallout of radioactive substances of nuclear accident inflicted extensive indirect damage including long-term evacuations, disruptions in debris disposal, restrictions on supply of agricultural and fisheries products, and sharp declines in the number of tourists. Furthermore, it resulted in the hike of fossil fuel cost replacing nuclear energy, imposing delay in countermeasures for global warming. Overall, the nuclear accident causes much greater indirect damage than the direct damage.

### Indirect Damage

- Damage on Business Operation (standstill of supply chain, absence of workers)
- Loss in Household Income (lost workdays, withdrawal of employment offers)
- Suspension of Utilities and Public Administration Services
- Cost for Emergency Responses (household, business, governments)
- Consequential Damage due to Transportation Disruptions
- Consequential Damage due to Lifeline Disruptions
- Emotional Distress (related to private property damage, evacuation, physical damage, unemployment and lay-off, ex-post damage, consequential damage)
- Risk Premiums (anxiety over the possibility to become disaster victims)

### 3.3 Types of Damage

There is other classification of damage than to determine whether it is direct or indirect. These classifications help to provide multifaceted perspectives to disaster analysis.

#### i. Structural vs. Non-Structural

**Structural:** Destruction of Houses, Buildings and Plants, Loss of Properties

**Non-Structural:** Casualties, Standstill of Business, Social Anxiety and Deterioration of Public Security

#### ii. Tangible vs. Intangible

**Tangible:** Properties, Infrastructure, Cost of Evacuation/Rescue/Reconstruction/ Rehabilitation, Casualties, Standstill of Business

**Intangible:** Social Anxiety, Deterioration of Public Security, Ill Rumor

#### iii. Monetary vs. Non-Monetary

**Monetary:** Buildings, Properties, Structures, Evacuation/Rescue/Rehabilitation/Reconstruction, Standstill of Business by Deterioration of Supply Chain

**Non-Monetary:** Casualties, Cultural Heritages, Social Anxiety and Deterioration of Public Security

### 3.4 Estimation of Damage

In general, direct damage is assessed by field surveys by government agencies, analysis of aerial and satellite photos and interviews. The number of fatalities, injuries, and evacuees is also estimated by government agencies.

In the case of the 2011 Great East Japan Earthquake, the amount of direct damage on general assets,



agricultural products, and public infrastructure has been estimated as \$ 210 billion, and the number of fatalities has been reported as 19,000.

In contrast, estimation of indirect damage is still a great challenge. The Input-Output Model is said to be the most reliable method, however, many argue over the applicability of this method, and therefore, there remains a need for further study to establish a more sound approach.

Besides, even with the Input-Output Model, it can only estimate monetary damage, meaning that the calculation of emotional distress or social anxiety is beyond the scope of this method. Although damage compensation by the Fukushima Nuclear accident by the owner of the plant including the decrease of sales of businesses and the emotional distress of evacuees is under the dispute, there is no standard method being recognized by the society.

In the 2011 Thai Flood the insurance money for Japanese manufacturers reached to \$6.3 billion but the total loss can not be calculated. [3]

Meanwhile, among direct damage, loss of life is occasionally calculated in monetary term, in the same manner as is calculated in life insurance schemes.

## 4 COUNTERMEASURES AGAINST DISASTERS

### - Defense, Retreat -

Now that disasters are social phenomena, ensuring safety by prevention, reduction and mitigation of damage is the responsibility of the government. The role of engineers is to provide information to the government and the public and implement the projects. In the complicated modern society, there are various types of damages as above-mentioned, therefore, the different types of management should be applied to each of them in accordance with their characteristics in an integrated manner.

Consequently, disaster countermeasures take a defensive approach such as disaster prevention, reduction or mitigation, though retreat from the disaster prone area would also be included in the options.

### 4.1 Research and Development, Statement of National Science Academies

National academies of sciences of 13 nations, including Science Council of Japan, issued a joint statement to urge governments to address climate change. The statement concluded that "Responding to climate change requires both mitigation and adaptation to achieve a transition to a low carbon society and our global sustainability objectives," and showed expectations for the governments as "Urge governments to support research on greenhouse gas reduction technologies and climate change impacts." [4]

The Science Council of Japan also issued its own statement "Adaptation to Water-related Disasters caused by Global Environment Change 2008", in which high expectations to the Academia in improving observation/monitoring, forecasting, and warning technologies are expressed. [5]

### 4.2 Structural Measures

Structural measures form the basis of disaster risk management. Although non-structural measures have also become increasingly important, public security cannot be achieved without structural measures.

#### 4.2.1 Countermeasures

##### i. Coastal Levee, Seawall, River Levee

Seawalls should have moderate height as excessively high walls will become the obstacle for social activities of the community (industry, tourism). Movable seawall is being studied as an answer to this problem. It is also essential to link them with forecasting and warning systems and evacuation schemes.

##### ii. Multi-Purpose Embankment, RC Building

It is effective to add barrier-like function to highway and railway embankments so that they can also be used as refuge facilities, and to provide key locations in the city with medium-rise RC buildings as shelters. The effectiveness of refuge function of RC buildings has been demonstrated in storm surge disasters in Bangladesh. Similarly, schools and city halls were used as shelters in the 2011 Great East Japan Earthquake.

##### iii. Ground Elevation, High Standard Levee

In contrast to the meltdown accident of the Fukushima Nuclear Plant, the Onagawa Nuclear Plant located

just 50 km north of the Fukushima Plant, had no fatal damage. The contrastive consequence is attributable to the design ground elevation of the Onagawa Plant, which was 5 m higher than that of the Fukushima Plant. The lower design ground level in the Fukushima Plant is the consequence of prioritizing short-term economic efficiency, which brought about such conclusive damage as a result.

For preventing damage caused by tsunami, flood, storm surge, a high standard levee, a levee with a broad crest width, is effective as it will prevent ruptures due to overtopping water.

#### **iv. Dam, Detention Reservoir**

Storm water captured in flood control facilities can be used for power generation or water supply during dry seasons. For recreational purposes, detention reservoirs can be used as parks when no water is stored. There are also cases that sport stadiums are constructed in detention reservoirs so that they can also be utilized as shelters.

#### **v. On-Site Detention**

On-site Storm Water Storage, Permeable Pavement, Detention in Private Premises are also effective.

### **4.2.2 Measures against Earthquake**

#### **i. Retrofitting of Buildings and Structures**

Structural reinforcement, retrofitting and seismic isolation is the main approach against seismic motions. However, private houses, which dominate most of the structural damage, are not always structurally safe. In order to ensure the design criteria in building construction, it will be necessary to boost public subsidies.

#### **ii. Anti-Liquefaction**

The ground foundation must be improved though its cost is over the capability of each resident.

#### **iii. Land Erosion, Land Slide**

Sabo works, Afforestation, Coast restoration incl. sand nourishing are effective measures.

### **4.2.3 Retreat, Relocation**

The most fundamental solution of all options is to retreat from disaster prone areas. This requires much deliberation considering the social impact it has, because this means not only giving up of properties built up over the years, but also losing cultures, histories, and industries rooted in the community.

Relocation of urban districts has already been in progress in pacific island nations, as a measure to address serious problems of sea level rise and ground subsidence.

Also in Japan, a community which lived by fishery and tourism decided to retreat to the higher ground area, after tsunami caused extensive damage in the original area in 1983 and 1993 successively. This relocation resulted in, however, a significant decline in the industries and the consequential loss of livelihood. Therefore, industrial prospective must be carefully examined before deciding relocation.

## **4.3 Non-Structural Measures**

### **4.3.1 Safety Design Criteria**

It is very important to establish design criteria for safe structures by the government. The criteria should cover both public infrastructure and private buildings. Of all, safety standards for seismic motion, crust movement (landslide, liquefaction, ground subsidence, etc.), and fire are particularly important. Formulation and establishment of these safety criteria requires support by Academia, as well as international cooperation for information exchange.

The aseismic standard in Japan had gone through multiple revisions after the Great Kanto Earthquake of 1923. The current version has been revised in such a manner to incorporate lessons learned in the 1995 Great Hanshin Awaji Earthquake, to the extent that the structural stability is maintained throughout the range of plastic limit of the structures.

On the contrary, in the Central Chile Earthquake of 2010, newly constructed highway bridges were collapsed, in spite of the fact that older bridges constructed on the Japanese criteria were not damaged. This was because the new design criteria for bridge had been revised for the purpose of reducing construction costs, and consequently, bridge girders lost strength against the transverse force (reported by WFEO-CDRM Study Team). [8]

The ground and floor elevation should also be defined as a part of the safety design criteria for structures in tsunami and flood prone areas.

#### 4.3.2 Land Use Regulation

In legal aspects, regulations for land use and development control must be implemented in accordance with urban planning. In particular, there are concerns in mega cities in Asian countries with increasing disaster risk as a result of sprawl.

- Development control: Regulate land use and development activities in disaster prone areas for preventing concentration of population and properties and reducing surface runoff in the event of heavy rainfall
- Regulation for disaster proof districts: Regulate urban development for mitigating disaster. However, excessive control may interfere with business operation in shopping districts. This was actually the case in a community in Kobe city in Japan.
- Other: Regulate overgrazing and [burn agriculture](#) for preventing desertification.

#### 4.3.3 Monitoring/Forecasting/Warning Systems

Establishment of monitoring networks is vital for smooth operation of disaster risk management systems. Such networks must be independently developed by each type of events, i.e., sudden onset, medium onset, and creeping onset events. Satellite-based observation techniques have made great advances in recent years.

While prediction of earthquakes has not yet been successful, significant progress has been made in forecasting extra long-term events such as climate change.

Forecasting and warning systems based on monitoring data have also been improved as coordination with mass media is being augmented. In Japan, an automated system has been introduced to connect earthquake monitoring networks with TV broadcast stations, transportation operators, major buildings, emergency management agencies, through which Emergency Earthquake Alert is released as soon as P wave reaches, whereby responsive measures can be taken before S wave reaches. In the 2011 Great East Japan Earthquake, there was no accident in bullet train of Japan Railways as automatic brakes stopped all bullet trains on receiving the alert.

#### 4.3.4 Education, Forecasting/Warning, Evacuation, Rehabilitation

There is no such way to completely avoid occurrence of extreme events on the scale exceeding the design safety level of structures. When such extreme event actually occurs, we must adhere to save human lives at the very least. For this purpose, it is important to raise public awareness through education for improving citizens' preparedness against the worst situation. It is also essential to establish information dissemination systems or "Now-casting" systems which provide information on present situation.

Specifically, public enlightenment will require indications of past disaster records (disaster monuments, posts with high-water level marks), hazard maps, notification of land use regulations, evacuation drills, signs for evacuation routes, and designation of shelters.

Local governments should play a key role in organizing self-defense organizations. In the 2011 Great East Japan Earthquake, all children survived in a community where evacuation drill was practiced at a regular pace.

#### 4.3.5 Emergency Management Center

For the sake of emergency management measures taken by the government, legal provisions should be adopted to restrict an individual's right at emergency. It is also important to establish the disaster management center.

Furthermore, systems against "cyber attacks" are vital for ensuring accuracy of communicated information. Federal Emergency Management Agency in the United States deals with variety forms of hazards other than natural disasters, such as fires, hazardous spills, and terrorism, and is known for producing measurable results.

### 4.3.6 Emergency Transportation System

Transportation routes are indispensable for evacuation, rehabilitation, and recovery. Above all, highways are of particular importance. Emergency transportation routes must be secured through deployment of military forces and private firms.

### 4.3.7 Disaster Insurance

Whereas reconstruction of affected areas is a responsibility of the government, it is expected that private disaster insurance will accelerate the speed of recovery. In the 2011 Thai Flood the insurance money of \$6.3 billion for Japanese manufacturers would assist the recovery of affected companies. [3]

It will also be possible to suppress sprawl into disaster prone areas by imposing higher premiums.

## 5 INTEGRATED DISASTER RISK MANAGEMENT

### 5.1 Responsibility of Engineers

Engineers prevent disasters on one hand, but increase disaster risk by development on the other hand. That is exactly why engineers must assume their greatest responsibility in achieving safe society by fulfilling the objective of infrastructure development.

### 5.2 Integrated Measures

Integration of structural measures and non-structural measures is the key for disaster risk management. Although structural measures are the basis of disaster countermeasures, we should bear in mind that natural events will take place on the beyond expectation scale of disaster prevention structures. Even if the load of such extreme events overwhelm the strength of structures and cause collapse, safety of citizens must by any means be ensured. In this regard, we must recognize that the principle of disaster risk management resides in nothing else but such extreme events beyond expectations.

Integrated operation of structural measures and non-structural measures is the very nature of disaster countermeasures. Fundamentals of integrated disaster risk management can be summarized as follows.

- i. Integrated implementation of structural and non-structural measures
- ii. Extensive measures with area-wide approach rather than separate measures distinctive with each structure
- iii. Predetermination of responses in the event of disasters beyond expectation
- iv. Establishment of disaster emergency management center in local agencies incorporating with neighborhood disaster management organizations
- v. Dissemination of emergency information on observation, forecasting, warning, and evacuation to residents
- vi. Formulation of evacuation and rehabilitation systems

These policies are explicitly stated in the CDRM Guideline for Water-related Disaster Risk Management (WFEO, 2009) and Integrated Water Resources Management Guidelines at River Basin Level (UNESCO, 2009). [6], [7]

Interestingly, management of water in an integrated manner has been proposed at World Water Forum 2012, Marseille France as the key solution for water issues including water-related disasters.

## 6. INVESTMENT AGAINST DISASTERS

### 6.1 Public Sector

The government bears a primary responsibility for protecting societies from disasters, while engineers of public and private sectors are the enforcing parties to fulfill this responsibility.

Engineers in public sector or private sector assess the frequency of natural events by means of stochastic analysis including extreme ones. Based on the results, disaster countermeasures should be prepared taking account of the value of the communities to be protected, available fund, and intention of the residents. They propose the measures to decision makers with the required investment amount and the time frame. Implementation, maintenance and operation of the projects are their role.

## 6.2 Private Sector

The amount which individuals or private sectors can use for disaster prevention is limited. It is rather general that public subsidies are provided. In private firms, the invest amount is determined by the balance between Cost (C) with Profit (P). The method is basically the same as the method used by the government, i.e., Cost Benefit method.

Private firms operate their business on the premise that public infrastructure will provide protection from disaster and so the economy will always be stabilized. Therefore, they have never been highly motivated for providing investment for disaster prevention by themselves. Sometimes, they are apt to forget the fact that they are protected by public infrastructure and that extreme events exceeding the capacity of infrastructure will occur.

In the 2007 Off Kashiwazaki Coast Earthquake, Japan, an auto part factory hit by this earthquake stopped production and caused tremendous disruption in supply chain of the car industry, to the extent as much as all car factories in Japan had to stop its production. Also in the 2011 Great East Japan Earthquake, collapsed highways caused disconnection between electronic and car part factories and major factories, terminating supply chain of these parts on the world-wide scale. Again, in the 2011 Thai flood, supply chain was disrupted in submerged industrial districts giving considerable impact on Thai and world economy as well. The latter two cases are the consequence of neglected investment for disaster prevention, without assuming the possibility of supply chain disruption as experienced in the 2007 Off Kashiwazaki Coast Earthquake. These experiences show that private firms should consider more resilient business model.

## 6.3 Evaluation Method

Public investment including those for disaster prevention purposes has usually been evaluated by annual average benefit and cost, i.e., Cost Benefit Analysis method. Basically, investment decisions have been made through this method which only evaluates a short-range economical benefit. The new evaluation method should cover the more comprehensive elements. It will improve the tendency of reluctance of private firms to invest for disaster prevention.

### 6.3.1 Benefit of Investment

The benefit of investment for disaster prevention is the amount of damage reduced by the investment. This is expressed in the annual average expected value according to the stochastic analysis. The damage has wide definitions as already described in the above sections, however, the cost benefit analysis generally takes account of only direct damage which is quantifiable in monetary term. This may be because the scale of disasters was not so large when this method was introduced, and also, there was no way to measure other damage, nor other scale than monetary value which can be used for damage. However, indirect damage is ever increasing due to economical complication and globalization, thus it must be taken into consideration in some way or other. If indirect damage is incorporated into cost-benefit analysis, the value for B will become greater. Of all indirect damage, those expressible in monetary term can be estimated by using the Input-Output Model. How to incorporate unquantifiable indirect damage into the cost benefit analysis is, however, another issue to be solved in future.

### 6.3.2 Cost of Investment

The annual cost (C) is the total of the depreciation cost and the maintenance cost of the measures invested. This has also been taking account only of direct monetary value. In future, the cost for environment deterioration caused by disaster prevention infrastructures and such should also be taken into consideration.

### 6.3.3 Evaluation

#### i. Evaluation by Expected Average Value

Previously, natural events such as meteorological events and geographical events have been considered as probability events. However, there has been change in the population of probability events due to recent global warming. More essentially, the probability of catastrophic events including geographical disasters, which occur once in hundreds or thousands years, may not be valid within 100-year observation period. Some even argue that catastrophic disasters are not probability events in the first place.

#### ii. Evaluation of Extreme Events

The 2011 Great East Japan Earthquake imposes the limitation of perceiving disasters as probability events. As a result, more voiced their views on investment for disaster prevention that it should be based on maximum record events. Such views are derived from the contrasting consequences between the Fukushima Nuclear Plant and the nearby Onagawa Nuclear Plant, specifically, the former suffered the meltdown accident whereas the latter had no accident, and that was largely attributable to the design safety level of the Onagawa plant to protect against the maximum recorded tsunami occurred in 869. In this regard, future consideration will be required to decide from which to apply, either probability events or maximum recorded events.

## 7 CONCLUSION

Catastrophic disasters threaten our lives with greater risk than ever. It is no one but ourselves who increased the disaster risk in the course of the development, which resulted in high damage potential and vulnerability to disasters. The forms of disasters and damages have also been diversified due to social complexities and globalization. It is the responsibility of governments and engineers to prevent or mitigate disasters and to construct resilient society under these changing circumstances. The conclusion is summarized as follows:

- i. In the light of the acknowledgement that every disaster is social phenomena, figure out the forms of disasters and types of damages, and implement structural and non-structural measures in an integrated manner
- ii. Develop new methods for the estimation of indirect and non-monetary damages
- iii. Develop new methods for the evaluation of investment both in quality and quantity, not only by monetary terms but also from comprehensive perspectives
- iv. Expand the vision against disasters to the entire society and make decisions on time scales of centuries including extreme events
- v. A new business model which is resilient against disasters should be developed by private sector
- vi. Recognize international cooperation as an indispensable prerequisite in this universalized modern world

## REFERENCES

- [1] Water and Disaster Management Bureau, Ministry of Land, Infrastructure, Transport and Tourism MLIT, Japan: Water-related Disaster and Adaptation to Climate Change, 2008.6
- [2] MLIT: Manual on Flood Damage Study (draft), 2007.4
- [3] The Nikkei Shinbun: Big deficit of insurance companies. 2012.5.19
- [4] Science Council of Japan et 10 National Science Academies: Joint Science Academies' Statement: Climate Change Adaptation and the Transition to a Low Carbon Society, 2008.6
- [5] Science Council of Japan: Statement on Adaptation to Water-related Disasters caused by Global Environment Change, 2008
- [6] WFEO-CDRM: Guideline for Water-related Disaster Risk management, 2009
- [7] UNESCO: Integrated Water Resources Management Guidelines at River Basin Level, 2009
- [8] Kawashima, K. et al.: Damage of Bridges due to the 2010 Maule, Chile, Earthquake, Journal of Earthquake Engineering 2010.11
- [9] ISHII, Y.: Infrastructure's Role Against Climate Change, Journal of Disaster Research 2009.2

**Dr. Vilas Mujumdar,  
U.S.A.**



255

VILAS MUJUMDAR

## **Understanding Vulnerability of Critical Infrastructure Systems to Reduce the Impact of Natural Hazard on Societal Functionality**

American Association of Engineering Societies

E-mail: [v\\_mujumdar41@yahoo.com](mailto:v_mujumdar41@yahoo.com)

### **ABSTRACT**

Critical civil infrastructure systems are essential for functioning of a community. These comprise transportation systems, water and wastewater systems, gas pipeline networks, electrical distribution network, and communication systems. All together, they can be classified as an *Engineering System*. Although designed to operate independently, many of these infrastructure systems are interdependent, such as electrical network with water and waste-water system, and electrical network with transportation systems. The vulnerability of the overall *engineering system* depends on the type and extent of interdependency among systems. In addition, the *engineering system* also interacts with societal and economic systems of the community. To reduce the impact of a natural hazard, it is necessary to understand these interdependencies which determine the vulnerability. This paper presents some methods and models on a system basis to protect infrastructure and deploy resources strategically to minimize the effects of a natural hazard.

## 1. GENERAL

Civil infrastructure systems are essential for daily functioning of a community. When a damaging natural hazard strikes a community, these systems are impacted and significant damage to them results in disrupting the function of a community. In general, eight infrastructure systems can be identified: *telecommunications, electric power systems, natural gas and oil, banking and finance, transportation, water supply systems, government services, and emergency services* (**President's Commission on Critical Infrastructure Protection, *Critical Foundations: Protecting America's Infrastructures, 1997***). However, for this paper the discussion is limited to five civil infrastructure systems i.e. *transportation systems, water and waste-water systems, gas & oil pipeline networks, electrical power systems, and telecommunication systems*. These infrastructure systems can be called as critical infrastructure systems.

It is important that during a hazard event the critical civil physical infrastructure systems keep functioning with minimal damage. These systems are interconnected and are interdependent. Although each infrastructure system is designed and operated as a separate engineered system, one system may have an interdependency relationship with other system, e.g. the transportation network depends on electrical power for its signaling and switching functions, and railroads need electrical power to operate. Similarly, water and waste-water systems need electrical power to operate pumps. If electrical network is damaged these dependent systems are significantly impacted.

The vulnerability of a system depends on the vulnerability of its components and their linkages with each other. The vulnerability of the overall engineering system depends on the nature and extent of interdependency among various constituent systems. For physical civil infrastructure systems, it is necessary to derive joint fragilities to understand the true nature and extent of the interdependent system vulnerability. The engineering system in-turn interacts with social and economic systems in non-linear ways that are not always clear or understood. The linkage relationships between engineering systems and socio-economic systems are highly complex, thus establishing meaningful measures of *overall community system vulnerability* difficult. The total hazard impact on the community can only be appropriately assessed when interaction of the engineering system with socio-economic systems is considered. Such understanding allows developing necessary steps in hazard impact reduction. Figure 1 shows the impact of various natural hazards on the physical damage systems and on the community based on infrastructure and societal vulnerabilities. A newspaper article from New Zealand stresses the impact on the community which may last for a long time.

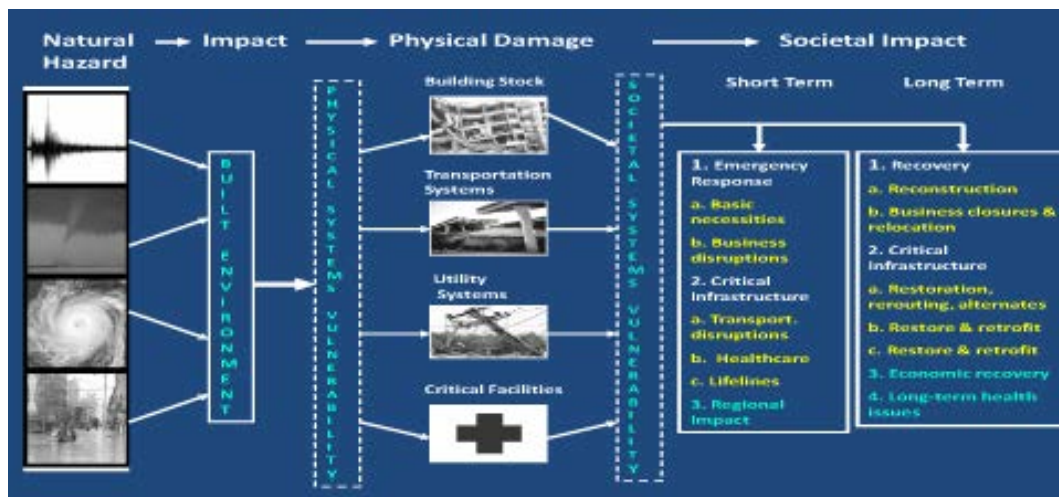

Fig. 1 Natural Hazard Impact on the Community



*Christchurch, New Zealand was struck by two large earthquakes on 4 September 2010 and 22 February 2011. The February earthquake had a human toll of 181 dead, and there was significant damage to buildings and infrastructure in the CBD and residential areas. Christchurch has continued to experience aftershocks, including two that caused further damage to infrastructure on 13 June, and these are likely to continue for some time*

### **Damage to Infrastructure**

Most of the network infrastructure in Christchurch was disrupted, or was constrained, in the initial hours after each earthquake. The networks showed some resilience, in that lifelines operators were able to make temporary repairs to progressively return services in the short-term, but it will be **many years before all services are fully restored.**

Following the February earthquake, the effects on infrastructure were:

- **Transport** - Minor damage to state highways, with local roads and structures (bridges etc) affected by shaking and liquefaction, while cordons around damaged areas of the CBD have led to traffic management issues. Lyttelton Port and Christchurch International Airport suffered some disruption, but were operational relatively quickly. **Air traffic control was out of action for several hours, which had flow-on effects for air travel over much of the country.**
- **Communications** - Initial disruption was due to cell sites being damaged or losing power, with some on batteries/generators for **several weeks**, but overall service was maintained.
- **Energy** - Initial disruption of electricity was gradually restored to most of the city, sometimes with temporary lines.
- **Water** - Council-owned water assets were significantly damaged. Drinking water has been progressively restored to suburbs over time. **Waste/storm pipes were damaged in the eastern side of the city and it is likely that a full rebuild will take many years.**
- **Social** - Forty-three Christchurch schools suffered moderate to serious damage, with six so badly damaged that their facilities are unusable - most are working out of temporary/shared locations; the **majority of local and central government services were relocated to areas outside the CBD**; some damage to the hospital occurred.

Focus on Christchurch

(National Infrastructure Unit, The Treasury, New Zealand, Apr. 2012)

## **2. CRITICAL CIVIL INFRASTRUCTURE SYSTEMS**

The ultimate objective of civil infrastructure systems is that they be *secure, sustainable, reliable, and functional*. Each of these areas has distinct stakeholder issues related to operations, jurisdiction and legal aspects. Under a natural hazard event, *reliability and functionality* play more significant roles. Critical civil infrastructure systems are briefly described below:

### **a. Transportation Systems**

The transportation systems include surface transportation and air transportation systems. The surface transportation may include highways, bridges, tunnels, ship canals and other waterways including ports and harbors, railroads and metro rapid transit networks. The air transportation network may include main and secondary airports, and heliports. Both of these transportation systems are used to transport goods and commodities, and people. Most surface transportation systems rely on electrical power.

### b. Water and Waste-water Systems

The water networks generally include: (1) the potable water systems that include water reservoirs, water treatment, storage, transmission, and distribution networks; (2) the waste-water systems that include the waste-water collection, treatment, storage, and disposal facilities; (3) the storm-water systems that include collection, holding ponds, treatment facilities, and disposal. Most water systems need pumping stations and rely on electric power for many functions. Many emergency management systems also rely on water systems.

### c. Gas and Oil Pipeline Networks

The natural gas and oil pipeline networks include the pipelines and rail systems. Gas networks may be operated by a separate entity or may be owned and operated by an electrical or water utility company. They may also be specialized in transmission of industrial gases and medical gases through separate networks. These networks may also include pump stations and rely on electrical power for those.

### d. Electrical power system

The electrical power system includes power generation stations, transmission systems, and distribution networks. Sometimes, several electricity generating companies may operate in an area or electricity is brought from a regional or national grid and distributed to the area by another entity. These entities may be government owned or private or a combination of both. Each form has its own unique set of requirements. These may depend on oil and natural gas for generation.

### e. Telecommunication Systems

The telecommunications systems are unique in the civil infrastructure systems as they form the core of each activity. These include conventional landlines that transmit voice and data, cell phone networks, fiber and copper cable systems for computer networks; satellite communications, radio and microwave systems; and commercial radio and TV facilities. Most of the communication facilities and networks are owned and operated by private firms. These depend on electrical power for operations. Figure 4 shows the electrical network system and its connection with water network.

## 3. INFRASTRUCTURE INTERDEPENDENCY

Although usually four types of interdependencies are normally defined, for civil infrastructure, three types are critical: *geographical interdependency*, *physical interdependency*, and *operational interdependency*. When sub-systems of infrastructures are in close proximity to be damaged by the same event, *geographical interdependency* results. This is a common occurrence in urban areas. *Physical interdependency* results if two systems are physically connected. For example, pumping stations are a part of water networks and they depend on the electricity for power. Thus a physically connected water and electrical system results. An example of physical interdependency of various utility systems in New York city is shown in fig. 2. *Operational interdependency* occurs when a part of the system is operated by another jurisdiction. For example, the



Fig. 2 Vulnerability due to physical Connectivity and geographic proximity



Fig. 3 Operational interdependency of Transportation Systems (Chile EQ-2010)

bridge authority or a tunnel authority is independent of the highway authority. Both authorities need to coordinate with each other for the highway system to function. Figure 3 shows operational and geographic interdependency of transportation systems in Chile.

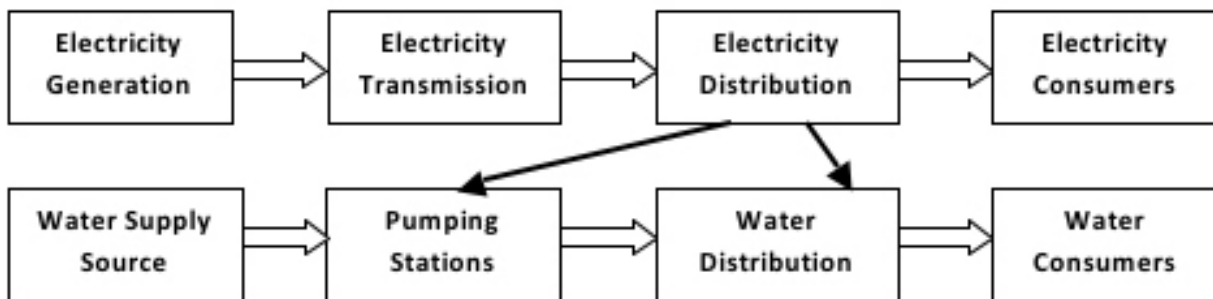

Fig.4 Electrical Network connected with Water Network

#### 4. VULNERABILITY

Vulnerability of a system to a hazard can be defined as a resulting aggregate outcome due to degree of exposure, system sensitivity, and system resiliency. *Total vulnerability includes potential loss of life, injury, civil infrastructure damage and disruption, economic costs to businesses and governments, and affects social infrastructure.*

Most physical systems are static, whereas, socio-economic systems are dynamic. Vulnerability of coupled Human-Environment System exposed to natural hazards depends on the dynamics of the system as the feedback loops play an important role in the behavior of systems. In physical infrastructure systems, component vulnerability can be assessed and quantified. Overall physical system-network vulnerability is difficult to quantify as different components and their locations in the system contribute different vulnerabilities to the system and the problem of determining total system vulnerability becomes a complex mathematical problem.

##### a. Sources of Vulnerability

Vulnerability is generated from two sources: *Inherent Design; and Operations.*

##### I. Inherent Design

When facilities are designed and constructed, they meet certain pre-determined criteria such as codes, specifications, regulations and performance criteria. Once designed and constructed, a certain level of vulnerability is built-in, for a given hazard. This cannot be changed. However, if designed-redundancies are a part of the overall system, they can reduce vulnerability. e. g. in transportation routes, alternate means of access can reduce vulnerability. Vulnerability related to design can be quantified.

##### II. Operations

Utility systems such as water are operated by human beings. Depending on the response during a hazard event, certain level of vulnerability is created in the system. Speed of response, deployment of resources to critical areas that are severely impacted and lack of defined responsibilities, all contribute to certain level of vulnerability. This type of vulnerability is difficult to quantify.

Vulnerability can be classified at different levels:

### b. Levels of Vulnerability

- Single Facility Vulnerability
- Sub-system Vulnerability
- System-Network Vulnerability

Measures and dimensions of vulnerability for each level are different. Semi-qualitative judgments can be made and rankings can be assigned. Examples of single facility vulnerability are shown in fig. 4 & 5.



Fig. 4 Parking garage – Northridge, CA, EQ – 1994  
(Inadequate capacity of non participating elements)



Fig. 5 Apt. Building - Loma Prieta, CA, EQ – 1989  
(Soft story)

*Sub-system* vulnerability can be defined as collection of single facilities, e.g. *several bridges on a highway, or several roads in a network of highways*. Overall vulnerability of the sub-system depends on the weakest link and the type of linkages. Operational vulnerability has similar issues as in a single facility plus additional issues of different jurisdictional considerations. An example of is shown in figure 6.

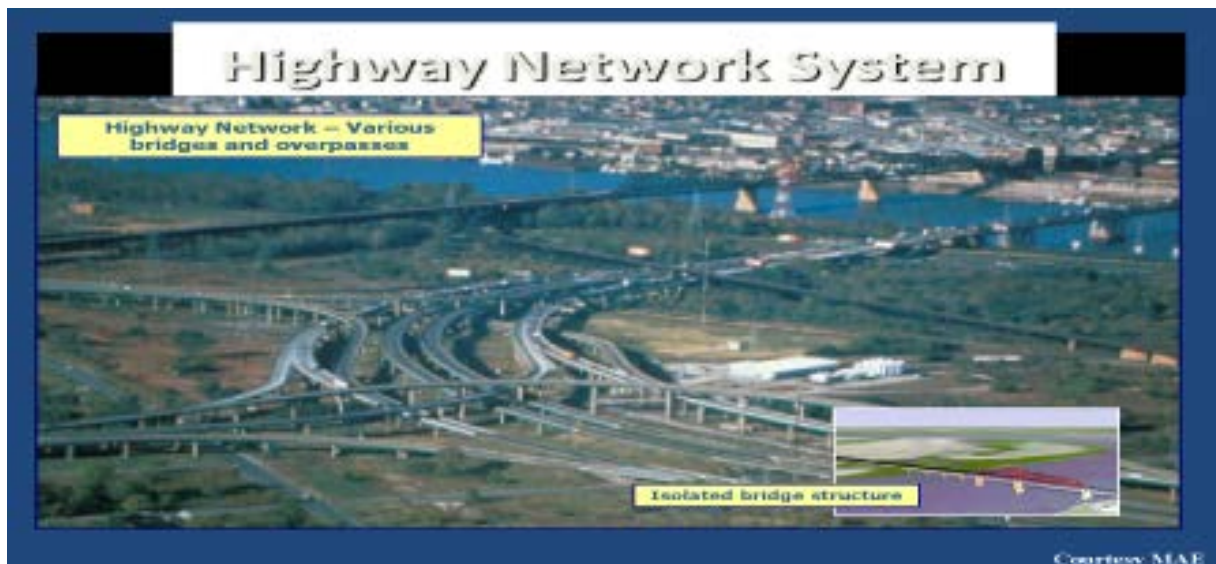

Fig. 6 Sub-system of highways and bridges – Mid-West, USA

A *System-Network* comprise of several sub-systems, i.e. different utilities, regional highway network etc. Overall vulnerability of a *System-Network* depends on the vulnerability of each sub-system and its effect on the other sub system (interdependency). Operational vulnerability is more complex to determine because of involvement of different stakeholders.

### c. Vulnerability is contextual

Given a degree of exposure, vulnerability depends on system sensitivity, and system resiliency. System sensitivity and system resiliency depend on each subsystem and links between subsystems. Contextual nature can be explained by the differences in casualties and damages for similar intensity of hazard events at different locations. For example in two earthquakes:

#### 1994 Northridge, CA Earthquake (6.9 mag.)

65 fatalities, \$40b economic loss, limited interruption in societal and economic systems

#### 1995 Kobe Earthquake (6.9 mag.)

5500 fatalities, \$150b economic loss, major interruption in societal and economic systems

Overall Vulnerability can be written as:

$$V_s = \sum Se, S_s, S_r \quad \text{-- Equation - 1}$$

#### Where,

Se – Degree of Exposure

Ss – System Sensitivity

Sr - System Resiliency

#### Degree of Exposure - Se

- System must be exposed to hazard otherwise no impact
- More the exposure, the larger the impact
- Subsurface conditions modify the exposure for earthquake events
- Distance from the epicenter modifies the exposure for earthquake events

*Numerical scores can be assigned to different degrees of exposure (e.g. 100 for most exposed – 10 least exposed)*

#### System Sensitivity - Ss

For a given exposure, sensitivity depends on:

- Type of physical system
- Capacity and Location of weakest elements
- Network redundancy

*Numerical scores for sensitivity can be assigned to different structural and infrastructural systems*

*(e.g. 8 for most sensitive – 1 for least sensitive)*

#### System Resiliency - Sr

- Resiliency is the ability to recover from a changed state
- Dimensions of resiliency are different for *physical systems* and for *societal systems*
- MCEER, Buffalo, NY – USA has developed four dimensions of resiliency:
  - Robustness – applies to physical & societal systems
  - Redundancy – applies to physical & societal systems
  - Resourcefulness – applies to societal systems
  - Rapidity – applies to societal systems *mostly*

*Numerical scores can be assigned to resiliency (e.g. 1 = least resilient – 10 for most resilient)*

An example of how various civil systems can be scored and evaluated is shown in Table 1. Various facilities and systems can be ranked on relative basis and information can be used for resource allocation decisions.

System	Exposure S <sub>e</sub>	Sensitivity S <sub>s</sub>	Resiliency S <sub>r</sub>	Overall Vulnerability V <sub>s</sub>
Industrial plant	7	8	1	16
4 story residential structure	10	7	3	20
Water supply station	4	6	2	12

Table 1 Relative Vulnerability Ranking of various facilities

## 5. JOINT FRAGILITIES OF ENGINEERING SYSTEMS

Fragility is a conditional probability of exceeding a limit state, given a level of hazard. Vulnerability in engineering systems can be modeled by developing fragility curves for individual components and for a single system. However, such component or a single system fragility approach not only underestimates the impact on the overall system, but also may misrepresent its nature and location. Systems with dependency relationships with other infrastructure systems need to develop joint fragility curves. Joint probabilities may magnify the impact or reduce the impact depending on the system. For example, damage to electrical system affects water systems causing flooding. Due to flooding some people may stay at home thus reducing the transportation impact, However, same flooding and mal-functioning of traffic signals causes additional strain on transportation systems, thus increasing the impact. Joint fragilities need input from one system to other.

It is necessary to identify the acceptance or limit conditions and the probability and intensity of a particular hazard to derive these joint fragilities. If no empirical data is available analytical and simulation approaches can be used. The interdependent infrastructure systems are connected to the societal and economic systems, which determine the *acceptance criteria*. Acceptable conditions can be denoted such as '*acceptable to have power out for 4 hours and no water for 2 hours*'. A general equation for System Fragility can be written in the following format.

$$\text{System Fragility} = P [D > C | H] \text{ subject to acceptance condition } A_c \quad \text{-- Equation 2}$$

Where,

$P$  = Probability,

$D$  = Demand on the system, and

$C$  = Capacity of the system

$H$  = A given hazard,

$A_c$  = Acceptance condition in the context of the hazard.

It is important to determine acceptance conditions in the society before deriving fragilities since these are contextual and vary from community to community and within sectors of a community. This approach needs to be used to derive joint fragilities for all the five infrastructure systems, given a particular set of acceptance conditions.

## 6. CONCLUSIONS

- Modeling interdependent infrastructure systems is a complex, multifaceted, and multidisciplinary problem. Standard engineering analytical and simulation techniques can be used for physical aspects of infrastructure systems. For example, electrical engineers commonly use power flow and stability analyses for electric power grids. These models can provide detailed information on the vulnerability of the system at the operational level.
- Modeling interdependent systems to derive joint fragility relationships is a more complex problem and needs data, detailed interdependency relationships at the design and operational level and condition assessment of the infrastructure systems.
- As difficult as it is to derive joint fragility of an engineering system, in a community engineering systems and socio-economic systems are also interdependent and interact with each other.
- Decisions on where to devote resources for improving critical infrastructure systems performance should be prioritized by considering the likelihood of hazard events, the impact of the hazards on the system, aging and deterioration of the infrastructure, and the value of improving infrastructure system for serving the needs of the community.
- Public- and private-sector systems owners and operators and others involved in protection and regulations of the critical infrastructure of society need to develop a greater awareness and a more complete understanding of interdependencies.
- The appropriate role of local, state, and federal governments in support of the private-sector response to disruptions also needs to be defined.
- Unless a proper understanding is developed and actions taken, infrastructure interdependencies can often lead to cascading failures resulting in disasters, with consequences far greater than initially anticipated.
- A joint effort by engineering and science disciplines along with public decision makers responsible for the management, maintenance, construction, regulation and operation of the infrastructure systems is required to develop new decision methodologies.
- The result of such an effort will be generating knowledge that will transform the decision systems to enable wholly new approaches to managing the systems in a synergistic way to provide reliable, functional, safe and secure, and sustainable physical civil infrastructure systems.

## REFERENCES

- Rinaldi, S, Peerenboom, J, and Kelly, T. Identifying, 'Understanding and Analyzing Critical Infrastructure Interdependencies'. IEEE Control System Magazine; 21:11-25.
- Department of Homeland Security, National Infrastructure Protection Plan 2006. Department of Homeland Security
- Mujumdar, V., 'Physical Civil Infrastructure Systems in Urban areas as a Complex Interdependent System', *International Conference on Urban Infrastructure*, International Association of Bridge and Structural Engineering, Oct. 2010, Venice, Italy
- Mujumdar, V., "Multi-hazards, Vulnerability, Mitigation, and Decision-making in Public policy Context", *University of Illinois*, Urbana-Champaign, IL Feb. 2009
- Mujumdar, V., "A Need for Risk-Consistent Approach to Multi-Hazard Engineering", *Symposium on Emerging Developments in Multi-Hazard Engineering*, New York, New York, Sept. 18, 2007
- Mujumdar, V., "Quantitative Risk Assessment, Public Policy, and Decision-making", *Proceedings, International Conference on Vulnerability and Risk Analysis and Management (ICVRAM)*, Baltimore, MD, Apr. 2011

Mujumdar, V., "Interdependency – A necessary Consideration for Risk assessment and Management of Critical Civil Infrastructure Systems", *First Asian-Pacific Symposium on Structural reliability and its Applications*, Singapore, May 23-25, 2012





**Dr. Chan Wirasinghe,**  
**Canada**  
**Samanthi W. Durage<sup>(1)</sup>,**  
**S.C. Wirasinghe<sup>(2)</sup>,**  
**Janaka Ruwanpura<sup>(3)</sup>**

## **An Introduction to False Tornado Warnings in Canada**

The Schulich School of Engineering

<sup>(1)</sup> PhD Student, <sup>(2)</sup> Professor, <sup>(3)</sup> Professor

E-mail: [wirasing@ucalgary.ca](mailto:wirasing@ucalgary.ca)

[swalawed@ucalgary.ca](mailto:swalawed@ucalgary.ca) / [wirasing@ucalgary.ca](mailto:wirasing@ucalgary.ca) / [janaka@ucalgary.ca](mailto:janaka@ucalgary.ca)

### **ABSTRACT**

Uncertainties associated with decision-making regarding tornadoes can lead to wrong decisions such as missed events and false warnings. One way of defining a false warning is a situation when the public is warned about a tornado and one actually does not occur. Consequently problems arise with credibility and future response to warnings. High probabilities of false warnings also can lead officials to refrain from issuing warnings. In Canada, there is minimal literature on false tornado warnings. This study is an introduction to the false warning issue in Canada. Attention is paid to analysing available false warning records in the Canadian Prairies and investigating whether they are really a problem in the public eye.

## 1. BACKGROUND

Tornadoes are one of the most powerful severe weather events associated with destructive forces of nature. According to the Glossary of Meteorology, a tornado can be defined as “a violently rotating column of air, in contact with the ground, either pendant from a cumuliform cloud or underneath a cumuliform cloud, and often (but not always) visible as a funnel cloud” (AMS, 2000). According to Grazulis (2001), a “...naturally occurring atmospheric vortex whose circulation extends from the ground at least to the base of a convective cloud” is the phenomenon of a tornado.

Tornadoes bring devastating impacts to lives and property. The lifting force created by rotating updrafts is the major force that lifts objects and structural elements into the air. Generally tornado damage is highly localized compared to other hydrometeorological disasters such as hurricanes and floods. Communities are impacted only when and if a tornado touches down on the ground. Early recognition of tornadoes and proper communication of warnings at the pre-touch down phase helps the public to be ready and respond appropriately and effectively (Durage et al., 2012).

Developments of tornadoes are complex and these small-scale events are hard to detect and forecast (Murphy et al., 2005). Currently, there is no proper way of predicting tornadoes precisely. However, better technological advancements coupled with real-time observations at the ground level have improved the detection and warning capability to a great extent. Doppler radars provide information on wind speeds that can be used to detect rotations in order to infer tornado activities and their approximate locations. In addition, satellite images and mathematical algorithms can be used to analyze the information and predict areas prone to tornado activities. Most importantly, ground level information provided by local weather watchers and spotters help the forecasters in their tornado warning decision making process during a severe thunderstorm event.

The Canadian Prairie region covers three provinces namely; Alberta, Saskatchewan and Manitoba. Meteorological conditions which produce severe summer thunderstorms can arise in any part of the prairies (Paul, 1982). Tornadoes are the most vigorous winds associated with thunderstorms (Figure 1). According to Environment Canada (EC), the responsible authority for issuing tornado warnings, approximately 36 tornadoes are reported on annually on average in the prairie region (UNSTABLE, 2012). Although the season of occurrence of severe thunderstorm and tornado outbreaks in the Canadian prairies is relatively short, the risks are however high.

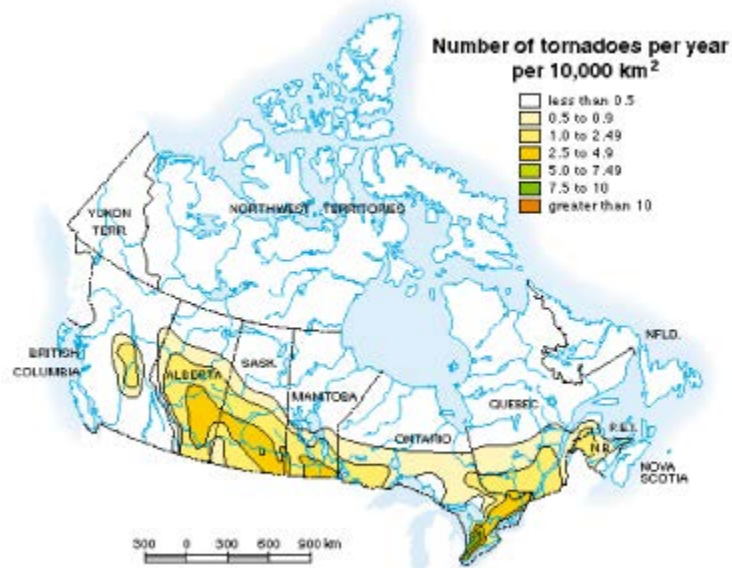

Figure 1: Tornado contour map in Canada

Source: Natural Resources Canada (2007)

Warning for a tornado hazard that threatens the safety of the public is the first priority of a forecaster. However, coping with a tornado event is quite challenging for the forecasters... They have to pay attention not only to the timeliness but the accuracy of warnings as well. Considering the urgency and the importance of issuing alerts, forecasters aim at issuing warnings in advance so that the public have time to prepare for evacuation. However, there is a trade-off between the efforts to achieve timeliness and the accuracy of warnings. The best available information to issue an early warning is not sufficient to guarantee an actual tornado event if a warning is issued. Therefore, it is inevitable that there are false warnings associated with tornadoes.

False Warning is a critical issue for tornado events that are subjected to major uncertainties as well as high levels of risk. False warnings can lessen the public confidence about the warning system and the response to future warnings. In Canada, no scholarly literature is yet available on false tornado warnings. This study is an initial examination of the false warning issue in Canada. Attention is paid to analysing available false warning records in the Prairie Provinces. The probability of false warning is calculated using 2010 and 2011 warning records. The false warning issue is further investigated to see whether they are really a problem in the public eye.

## 2. WARNINGS AND FALSE WARNINGS FOR TORNADOES

“Warnings are the culmination of a sequence of actions ... that act to alert the public to a heightened probability of high-impact weather, minutes, hours or even days in advance” (Stensrud et al., 2009). Issuance of a warning for a tornado is generally done when certain criteria followed by the forecasters is satisfied. False Alerts can be recognized as communications regarding events that have been forecasted but not actually occurred. Uncertainties in forecasting science and technology as well as problems associated with verification of event occurrences can increase false alerts (Barnes et al., 2007).

There are various arguments about the false warning issue. According to Edwards and Lemon (2002), “false alarms can be costly and can serve to slow or prevent a future response”. Especially the repeated issuance of false warnings can reduce the public’s concern for future tornado warnings and it is known as the “cry-wolf effect”. However, according to Barnes et al. (2007), “evidence for the cry-wolf effect in natural hazards research, however, has not been forthcoming.”

Looking at the social science perspective of false warnings, Mileti and Sorensen (1990) say that

“...the effectiveness of people’s response to warnings is not diminished by what has come to be labelled as “cry wolf” syndrome, if they have been informed of the reasons for previous “misses”. Obviously, there should be a negative effect on subsequent public response if false alarms occurred frequently, if no attempt was made to explain why there were false alarms, and if the cost of response is high. Yet, false alarms, if explained may actually enhance the public’s awareness of a hazard and its ability to process risk information in subsequent warning events. False alarms are better viewed as opportunities for conveying information than as problems”.

Barnes et al. (2007) have developed a conceptual model that presents a more general depiction of warnings for possible events (Figure 2). Instead of having a yes-no categorization of warnings, this spectrum is used to demonstrate the range of accuracy of warnings. This model is especially good at assessing forecasters’ performance skills in recognizing events that require warnings to be issued. However, after a disaster event, the public does not receive much information about the range of accuracy of the warning they received and their perception of the event is more likely to be under the yes-no categorization. Therefore, the false warning issue plays a major role in forecaster-public interaction in dealing with disaster warnings.

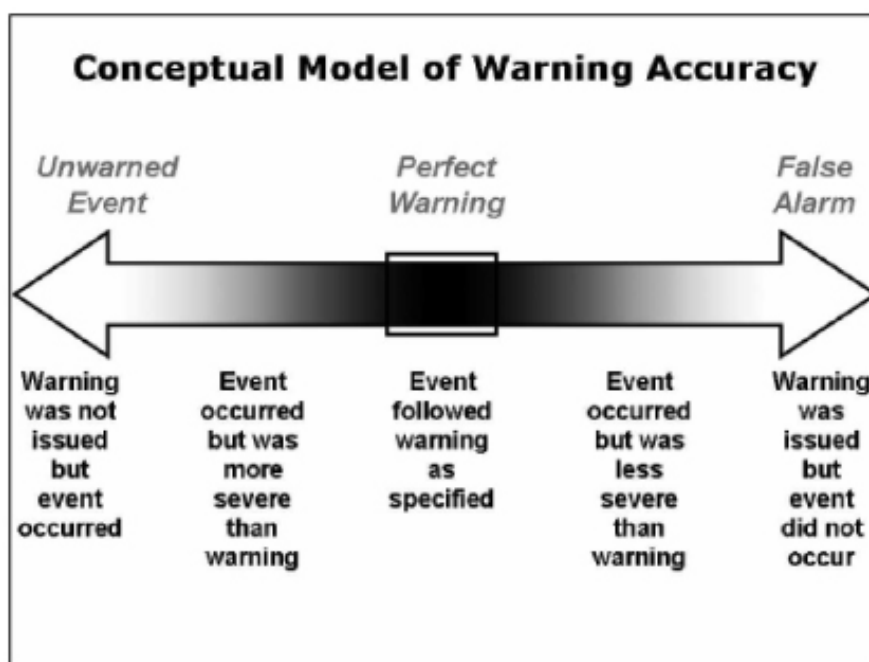

Figure 2: Conceptual Model for Warning Accuracy

Source: Barnes et al. (2007)

The high number of false warnings is a major problem associated with tornadoes. From the public's point of view, false tornado warnings question the level of risk that has to be accepted by the public in responding to the disaster. Analysing the influence of false alarms on casualties from US tornadoes, Simmons and Sutter (2009) have shown strong evidence that higher false alarm rates significantly increases tornado fatalities and injuries in future events. From the disaster management point of view, false warning is an important measure to understand when planning for future tornado events.

### 3. PROBABILITY OF FALSE WARNINGS

There are various terms used in the literature to interpret false alarms such as "false alarm rate" and "false alarm ratio". To avoid the confusion it is good to use the term "probability of false alarm" or "probability of false warning" (Barnes et al., 2009).

Environment Canada (EC) defines a severe weather event when at least one of the following conditions is satisfied.

- Wind gusts of 90 km/h or greater, which could cause structural wind damage;
- Hail of two centimeters (cm) or larger in diameter;
- Convective rainfall amounts of 50 mm or more of rain is expected within one hour.
- Tornadoes

According to EC's public alerting criteria, a tornado warning is issued "when a tornado has been reported; or when there is evidence based on radar, or from a reliable spotter that a tornado is imminent" (EC, 2012).

The Canadian Prairie Region is one of the most active regions for severe summer thunderstorms. "On average, 203 severe events are reported over the prairies each summer" (UNSTABLE, 2012). Of them, an average of 36 tornadoes is reported annually (Table 1).

Event type	Alberta	Saskatchewan	Manitoba	Total Average for the Prairies
Tornado	13	14	9	36
Hail	39	33	25	97
Wind	12	20	13	45
Rain	10	7	8	25
All events	74	75	55	203

Table 1: Average number of summer severe weather reports for the Prairies, 1984 to 2006

Source: (UNSTABLE, 2012)

#### 4. TORNADO WARNING DATA IN THE CANADIAN PRAIRIES

A database containing the tornado warning records in the Canadian Prairies in 2010 and 2011 was collected from the EC. This database contains information regarding tornado warning issuance and expiration dates, times, the areas warned and discussion about the reasons for issuing a tornado warning. Actual tornado occurrences reported by the EC in 2010 and 2011 were also collected.

Several caveats were identified in analysing the county-based or region-based tornado warning records. The following criteria were used to recognize individual warning issuances and false warning records associated with them.

- There are cases that tornado warning(s) is/are issued for one or several counties or regional municipalities just after an actual tornado is reported. In this case, warnings are issued for multiple regions considering the uncertainty of multiple touch downs of the same tornado. In this analysis, these warnings are counted separately in determining the number of warnings issued. If there is a tornado warning for a region that has experienced a tornado touchdown several minutes before the warning issuance or within the warning period, it is counted as a "True warning". The absence of tornado reports in other regions that have been warned is considered as false warnings for those regions.
- Sometimes, it is necessary to add new warning regions to the warning area based on the movement of the storm. Addition of new warning regions during the updates of the same set of warnings are considered as new warnings and analysed separately in determining false warnings.

Individual tornado occurrence reports (EC, 2012a) were compared with the tornado warning records (EC, 2012b) to determine the joint occurrence of a tornado and a warning issuance. Absence of such an intersection for a warning is counted as a false warning record (Table 2).

Year	Number of Tornado Warnings	Joint occurrence of a tornado and a warning issuance	Number of False Warnings
2010	190	8	182
2011	76	7	69
<b>Total</b>	<b>266</b>	<b>15</b>	<b>251</b>

Table 2: Tornado Warning Records in the Canadian Prairies

False warning probability for the two year period can be calculated as  $251/266 = 94.3\%$ . Year 2011 has a little improvement compared to the year 2010. The probability for 2011 is 90% and around 5% lesser than year 2010. With this figure for 2011, nine out of ten tornado warnings are recorded as false warnings. This is not a surprising fact when it is compared with the well-established US tornado warning system. Despite technological advancements, strong spotter networks for ground level observation and verification, and all other efforts to reduce it, the false warning probability in the U.S.A. is 75% (Barnes et al., 2007).

In this analysis, tornadoes reported by the EC were used as actual tornado occurrence records. This does not necessarily include all tornadoes that may have occurred over the prairies in 2010 and 2011. There are some tornadoes that can go undetected and unreported or cannot be verified clearly. Hence, there is some amount of uncertainty associated with the data used for calculating the probability of false warnings.

## 5. FACTORS BEHIND FALSE WARNINGS

Generally every storm begins as a non-severe storm and some develop to the severe stage. Forecasters' aim is to identify the severity of the future storm as early as possible in order to warn the public with a sufficient lead time. However, it is important to understand that tornado detection and warning is much more challenging especially considering the chaotic nature of storms and tornado development. Further, tornado predictability is highly influenced by factors such as technological capabilities and limitations, spotter availability, and the state of scientific knowledge (Brotzge et al., 2011).

Besides radar and satellite based observations, and automated guidance products for forecasting, eye witness observations plays a major role in successful tornado warnings. In the Canadian Prairies, active spotter or weather watcher involvement is limited to some populated regions in the country. Therefore, obtaining local level information about an imminent tornado prior to issuing a warning is not always possible. However forecasters have to issue a warning for the potential danger from a weather event such as the rotation from a storm observed from Doppler radars. Despite the information uncertainty, tornado warnings are issued to avoid possible threats to lives and property. Discussions quoted from tornado warning bulletins justify the reasons for warning issuance.

"AT 5:30 PM DOPPLER RADAR INDICATED AN INTENSE THUNDERSTORM 40 KM EAST SOUTHEAST OF PORTAGE LA PRAIRIE, NEAR ELIE. RADAR INDICATES ROTATION WITH THIS STORM AND MAY BE CAPABLE OF PRODUCING A TORNADO."  
(TORNADO WARNING ISSUED AT 5:38 PM CDT TUESDAY 13 JULY 2010.)

"AT 5:25 PM CST RADAR INDICATES A POSSIBLE TORNADO AS STRONG ROTATION IS DETECTED JUST TO THE NORTHWEST OF MAYFAIR. THIS STORM IS MOVING EASTWARD AT 30 KM/H. THIS IS A WARNING THAT SEVERE THUNDERSTORMS WITH TORNADOES ARE IMMINENT OR OCCURRING IN THESE REGIONS. MONITOR WEATHER CONDITIONS. TAKE IMMEDIATE SAFETY PRECAUTIONS."  
(TORNADO WARNING ISSUED AT 5:26 PM CST MONDAY 18 JULY 2011.)

With these reasonable explanations, if made widely and easily available, the possibility that people will question a false warning is reduced. However, repeated occurrence of false warnings can lessen the immediate response to future warnings.

The Canadian Prairie Region is a very large area in terms of forecasting. Only "a single severe weather forecaster is responsible for the provision of warnings for the area coverage of about ten radars (Joe et al, 2012)." However paying attention to several radar images does not help to provide a deep analysis on the behaviour of a given storm. Although a tornado potential is detected initially and a warning is issued, atmospheric conditions may change rapidly and the storm may not spawn an actual tornado.

From the forecasters' point of view, the inability to verify a tornado occurrence is also a problem associated with a high number of false warnings. Even if a tornado occurs following a warning, it is counted as a false warning if the occurrence cannot be verified. The Canadian Prairie Region has many sparsely populated areas with population density of less than one person per km<sup>2</sup> (UNSTABLE, 2012). Therefore, it is not unlikely that a tornado might go undetected to the human eye. There also can be close calls (Barnes et al., 2007) such as downbursts and wind gusts that have a similar damage potential but are not counted as tornadoes.

Personal communication with an EC warning preparedness meteorologist in the Prairie Region provided rational explanations regarding the false warning issue and helped to focus on the importance of looking at the warning system in different ways and not judging the efficiency by only focusing on the false warning probability (Personal Communication, 2012). For example, during a severe storm event, a report of a funnel cloud appearing close to one corner of the City of Calgary is a sufficient reason to issue a tornado warning for the whole city even if a no touchdown is reported later. Although the event is recorded as a false warning, the funnel cloud appearance is a "close call" for a tornado. This false warning does not say that the warning system is not good and a million of people have been warned unnecessarily. Public needs to understand the uncertain nature and imposed vulnerability leading to tornado disasters.

## 6. CONCLUSION

In this paper, we have analysed the false tornado warnings issue in Canada. Analysis of the tornado warning data in the Canadian Prairies provides an insight into the false warning problem. It is noteworthy considering the high uncertainties associated with tornado detection and warning and verification process, it is not rational to judge the efficiency of a warning system only considering the false warning issue. With these uncertainties associated with tornadoes and complications faced by human forecasters, public also would need to be patient to accept false warnings.

## ACKNOWLEDGEMENTS

This research is supported by the Calgary Emergency Management Agency (CEMA). Travel support to attend the WFEO Committee on Disaster Risk Management (CDRM) and associated technical sessions is provided by the Association of Professional Engineers and Geoscientists of Alberta (APEGA).

## REFERENCES

- AMS (2000). Glossary of Meteorology, Retrieved February 10, 2010 from <http://amsglossary.allenpress.com/glossary>.
- Barnes, L.R., Grunfest, E.C., Hayden, M.H., Schultz, D.M., Benight, C. (2007). False Alarms and Close Calls: A Conceptual Model of Warning Accuracy, *Weather and Forecasting*, Vol. 22, pp.1140-1147.
- Barnes, L.R., Schultz, D.M., Grunfest, E., Hayden, M.H., Benight, C.C. (2009). Corrigendum: False Alarm Rate or False Alarm Ratio?, *Weather and Forecasting*, Vol.24, Pp. 1452-1454.
- Brotzge, J., Erickson, S., Brooks, H. (2011). A 5-yr Climatology of Tornado False Alarms, *Weather and Forecasting*, Vol. 26, Issue 4, pp.534-544.
- Durage, S.W., Wirasinghe, S.C., Ruwanpura, J.Y. (2012). Comparison of the Canadian and U.S. Tornado Detection and Warning Systems, *Natural Hazards*, Available online at <http://www.springerlink.com/content/nqt6775768275w66/>
- EC (2012). Public Alerting Criteria, Retrieved from <http://www.ec.gc.ca/meteo-weather/default.asp?lang=En&n=D9553AB5-1#tornado> on 13th June 2012.
- EC (2012a). Tornado Prairie Tornado Chronology 2010 and 2011, Environment Canada, Obtained on 29<sup>st</sup> February 2012.

- EC (2012b). Tornado Warnings in the Canadian Prairies 2010-2011, Ontario Climate Centre, Environment Canada, Obtained on 1<sup>st</sup> March 2012.
- Edwards, R., and L.R. Lemon, 2002: Proactive or reactive? The severe storm threat to large event venues. Preprints, 21st Conf. Severe Local Storms, San Antonio, Amer. Meteor. Soc., 232-235.
- Grazulis, T.P. (2001). The Tornado: nature's ultimate windstorm, University of Oklahoma Press, Norman, USA, 2001.
- Joe, P., Dance, S., Lakshmanan, V. Et al. (2012). ,Automated Processing of Doppler Radar Data for Severe Weather Warnings, Retrieved on 18th June 2012 from <http://www.intechopen.com/books/doppler-radar-observations-weather-radar-wind-profiler-ionospheric-radar-and-other-advanced-applications/automated-processing-of-doppler-radar-data-for-severe-weather-forecasting>
- Mileti, D., and Sorensen, J. (1990). "Communication of emergency public warnings." ORNL-6609, Oak Ridge National Laboratory, Oak Ridge, Tennessee. Retrived on 15<sup>th</sup> June 2012 from <http://orise.orau.gov/csepp/publications/files/CommunicationFinal.pdf>
- Murphy, B., Falkiner, L., McBean, G., Dolan, H. and Kovacs, P. (2005). Enhancing Local Level Emergency Management: The Influence of Disaster Experience and the Role of Households and Neighbourhoods, Institute for Catastrophic Loss Reduction, ICLR Research, Paper Series – No. 43, Canada.
- Natural Resources Canada (2007). Map of the Annual Number of Tornadoes in Canada, Retrieved on 12<sup>th</sup> July 2011 from [http://atlas.nrcan.gc.ca/site/english/maps/environment/naturalhazards/naturalhazards1999/majortornadoes/number\\_tornadoes\\_per\\_year.gif/image\\_view](http://atlas.nrcan.gc.ca/site/english/maps/environment/naturalhazards/naturalhazards1999/majortornadoes/number_tornadoes_per_year.gif/image_view)
- Paul, A.H. (1982). The Thunderstorm Hazard on the Canadian Prairies, Geoforum, Vol . 13, No . 4, pp . 275-288.
- Personal Communication (2012) Discussion with Bill McMurtry, Warning Preparedness Meteorologist, Environment Canada, Canada 29<sup>th</sup> February 2012.
- Simmons, K.M. and Sutter, D. (2009). False Alarms, Tornado Warnings, and Tornado Casualties, Weather, Climate, and Society, Vol.1, pp. 38-53.
- Stensrud D.J., Xue, M., Wicker, L.J. et al. (2009). Bulletin of the American Meteorological Society, Vol. 90, Issue 10, October.
- UNSTABLE (2012). Understanding Severe Thunderstorms and Alberta Boundary Layers Experiment, Retrieved on 15th June 2012 from <http://ebookbrowse.com/unstable-science-final-pdf-d314471272>



## Dr. Leon Cizelj, Slovenia



273

LEON CIZELJ

### The Augmented Role of Education and Research in the Safety of Nuclear Power Plants

Jozef Stefan Institute, Ljubljana, Reactor Engineering  
Division

E-mail: [leon.cizelj@ijs.si](mailto:leon.cizelj@ijs.si)

#### ABSTRACT

Research and research based education have been in the forefront of the peaceful use of the nuclear energy since the very beginning in the 1950-ies. The influx of young people in Europe and especially in the USA started to dwindle during the oil crisis in the 1970-ies and almost vanished after the Chernobil accident in 1986. For more than two decades to follow, the nearly constant fleet of nuclear power plants was then managed by the gradually ageing workforce. The first warnings about the dwindling expertise and calls for imminent adjustments started at the end of 1990-ies.

The augmented concerns about education and research have been regularly perceived in the analysis of the accidents and have been raised up in the analyses of recent events, including the Fukushima Daichi nuclear accident and the fatal crash of Air France flight 447 over the Atlantic in June 2009.

A review of the current status of nuclear education in European Union is followed by some proposals for future enhancements of safety related education and research.

## 1. INTRODUCTION

Research and research based education have been in the forefront of the peaceful use of the nuclear energy since the very beginning in the 1950-ies. The necessity of research and education within any nuclear civil program has also been explicitly coded in the legislation (EURATOM 1957; IAEA 1996). The development and early implementation phases did, as customary in the science, engineering and technology, fascinated many gifted young people. The influx of young people in Europe and especially in the USA started to dwindle during the oil crisis in the 1970-ies and almost vanished after the Chernobil accident in 1986.

For more than two decades to follow, the nearly constant fleet of nuclear power plants was then managed by the gradually ageing workforce. The nuclear departments and infrastructure at universities and research establishments were growing older. A significant number of them changed the fields of interests or simply vanished after the retirement of the key personnel. The first warnings about the dwindling expertise and calls for imminent adjustments included (OECD/NEA 2000) and (CCE Fission 2001).

The augmented concerns about education and research have been regularly perceived in the analysis of the accidents. Ed Frederick, control room operator at the nuclear power plant at the Three Mile Island during the accident in 1979, stated that "An operator must never be placed in a situation which an engineer has not previously analyzed." (Frederick 1988). Similarly, a statement of April 4, 2011 (Birkhofer, Alonso et al. 2011), written by the veterans of nuclear safety research after the stabilization of damaged reactors in Fukushima Daiichi, noted "In fact, complex combinations of initiating events unforeseen in plant designs resulted in all the severe accidents to-date. In addition, these accidents took emergency responders outside the range of circumstances for which they were trained and equipped. Moreover, hindsight shows that relatively inexpensive improvements, detectable by more extensive analysis beforehand, may have avoided these accidents altogether." Finally, the independent commission of the Japanese parliament (The National Diet of Japan 2012) investigating the Fukushima Daiichi accident clearly noted the knowledge and education issues while transferring most of the blame for inadequate management of the accident to the Japanese culture, being among others also very closed to the knowledge coming from abroad.

The extraordinary importance of education and training in accident prevention has been frequently pointed out also in the (civil) aviation safety. According to research performed by NASA in 2005, more than 86% of the "textbook" emergencies have been handled well by the crews as opposed to merely 7% of the "non-textbook" emergencies (Burian, Barshi et al. 2005). Insufficient education and training seems also to be among the dominant factors, which led to poor diagnosis and finally to the fatal crash of Air France flight AF 447 in June 2009 (Bureau d'Enquêtes et d'Analyses pour la sécurité de l'aviation civile 2012).

In this paper, a review of the current status of nuclear education in European Union is followed by some proposals for future enhancements of safety related education and research.

## 2. CURRENT STATUS IN NUCLEAR EDUCATION AND RESEARCH IN EU

Recent report produced by the European Human Resource Observatory for Nuclear (EHRO-N) provides the first comprehensive analysis of the needs and supplies for the nuclear workforce in the European Union (Simonovska and Estorff 2012). The total number of people working in the nuclear field in the EU in 2009 has been estimated to approximately 77.000. The structure of those employees is indicated in Figure 1.

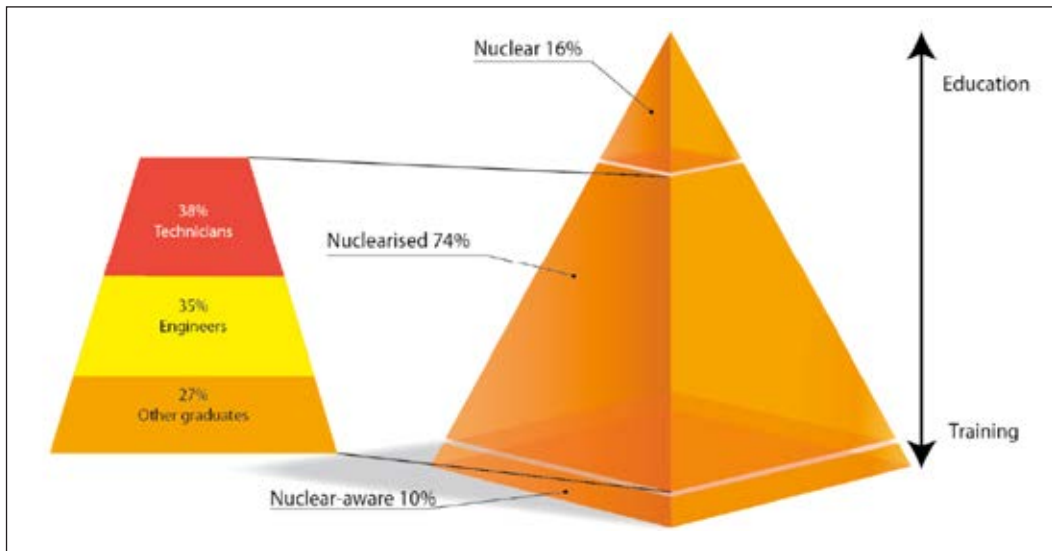

Figure 1 The structure of the nuclear workforce in European Union (Simonovska and Estorff 2012)

It is clear that only about the 16% (12.300) of the employees received education in nuclear disciplines. About 74% (57.000) of the workforce has been “nuclearized”, which assumes an education in science or engineering (or other disciplines for some of them) followed by intensive in-house training on topics related to nuclear. About 10% (7.700) of the employees are seen as “nuclear-aware”: their jobs do not require in-depth understanding of the nuclear topics. Nevertheless, also the nuclear-aware employees have to be properly acquainted with the nuclear safety culture.

The 2009 graduates in nuclear disciplines in EU comprise 863 B.Sc., 1668 M. Sc. and 302 Ph.D. (Simonovska and Estorff 2012). It should be noted that the nuclear disciplines involve a wide range of science and technology. Examples include reactor physics, radiation protection, nuclear thermal hydraulics, nuclear materials etc. No quantitative details on the specific graduation topics are given in (Simonovska and Estorff 2012). It is estimated that the current supply of nuclear graduates is sufficient to replace about 70% of the retirees from the existing workforce. This assumes that the number of graduates will remain constant and that all nuclear graduates will acquire jobs in the nuclear industry in EU. Expectations of young engineers reported in Figure 2 on the other hand clearly show that a substantial part of the nuclear graduates may search for jobs outside EU and outside nuclear sector (Simonovska, Estorff et al. 2011).

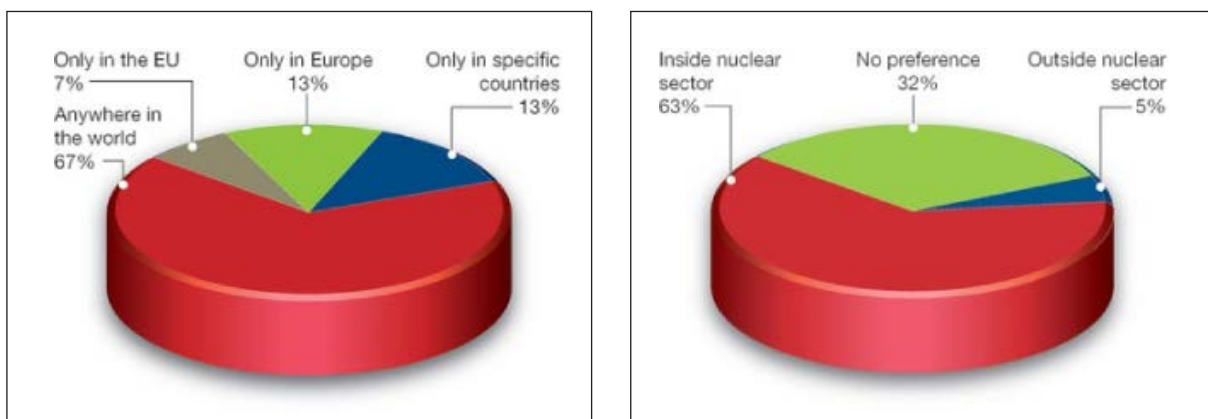

Figure 2 The mobility (left) and employment (right) preferences of young nuclear engineers (Simonovska, Estorff et al. 2011)

Rather detailed data on the age of the current nuclear workforce in the EU and the age of the nuclear power plants in Europe are also provided (Simonovska and Estorff 2012). They appeared to be sufficient to generate a simulation depicted in Figure 3. The existing workforce is assumed to retire at the age of 65. The time development of the number of available active experts is depicted with black curve. It is very interesting to note that the black curve fits very well with the green curve, indicating the number of operating nuclear power plants (assuming to cease the operation after 40 years of operation). It seems that the current workforce is sufficient in the case of the general phase-out of the nuclear energy. It must be noted here that a substantial number of nuclear experts will be needed also to safely dismantle the retired nuclear power plants and to safely manage the disposal of the radioactive waste. These will have to be educated in the future.

The extended nuclear power plant operation (towards 60 years) is widely considered in the USA and EU and has already been accepted for some nuclear power plants within the EU. Some new nuclear power plants are also currently being built (Finland, France) and will be most likely followed by further new projects, which are currently in the preparation (Lithuania, Czech Republic, Poland, Great Britain etc.). This augments the need for further strengthening the nuclear research and education.

Please note that the workforce situation in EU depicted in Figure 3 is very similar to the situation in the United states (Li, Dale et al. 2009), which is depicted in Figure 4.

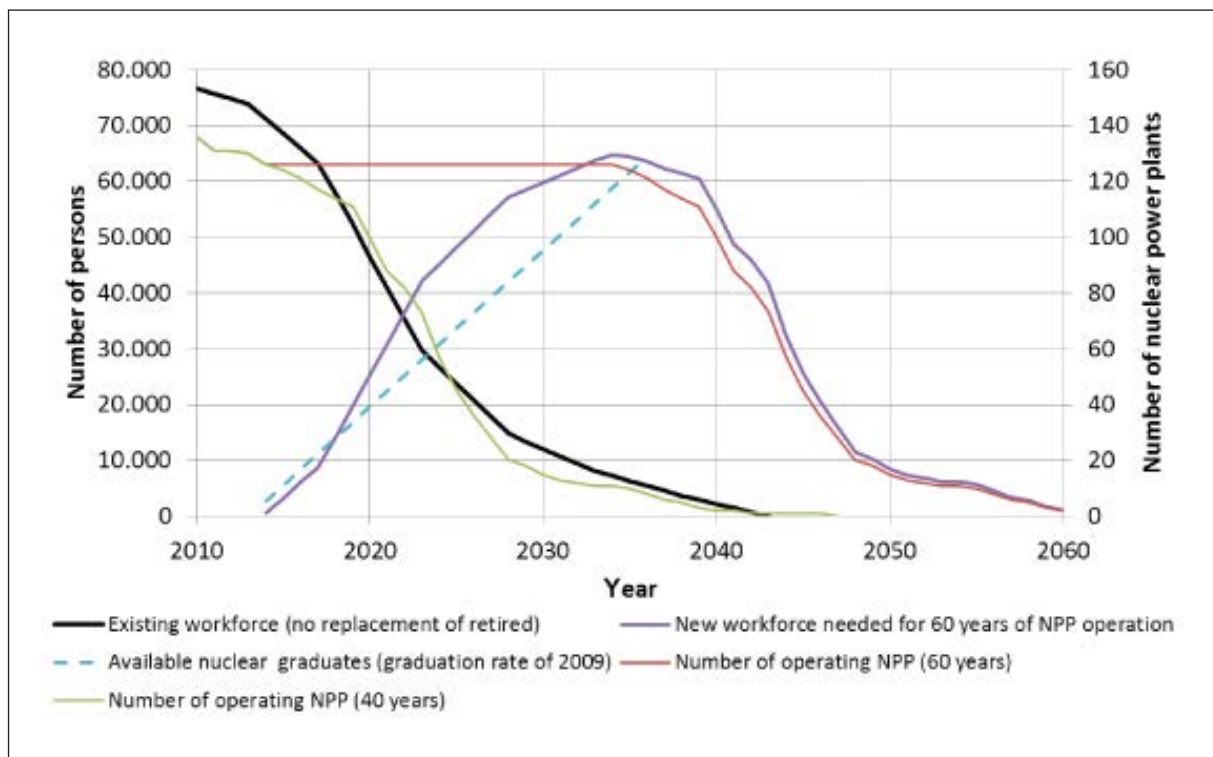

Figure 3 The simulated time development of nuclear workforce in the EU. Based on data by (Simonovska and Estorff 2012). Retirement age assumed at 65 years.

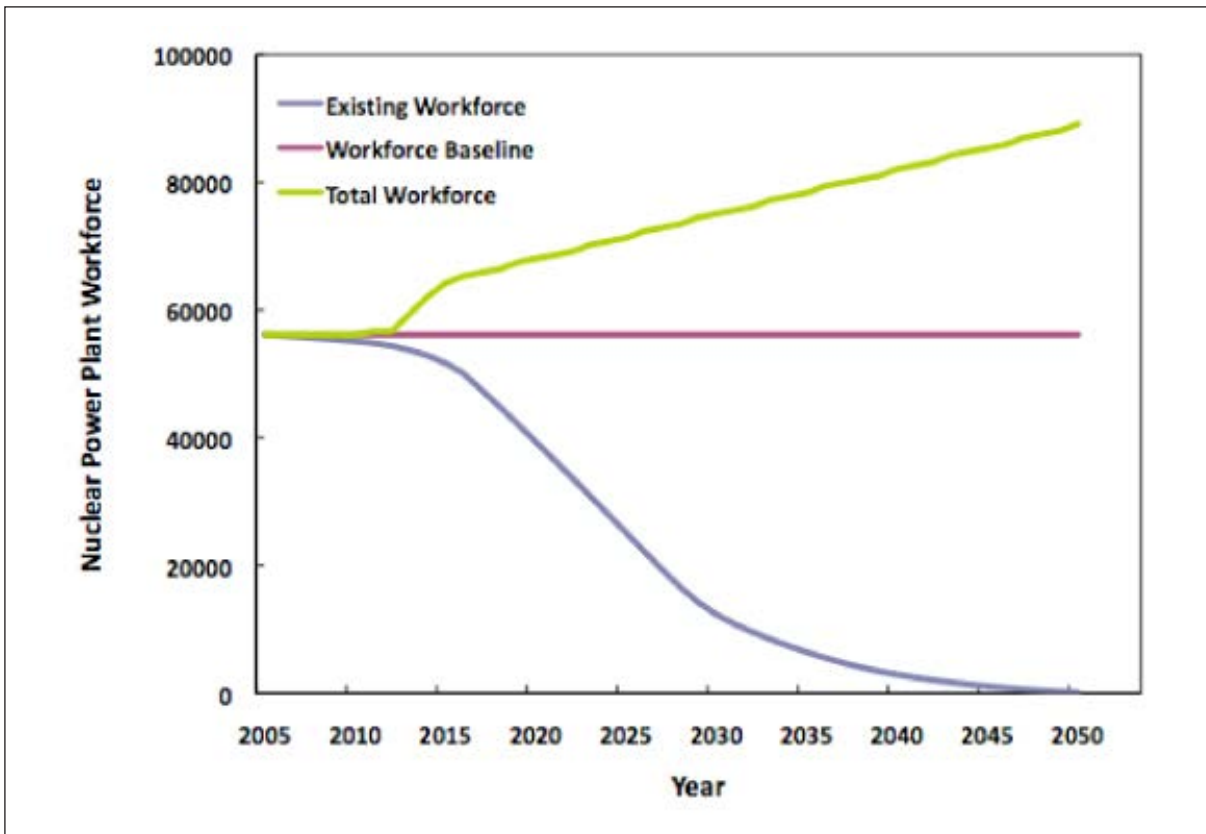

Figure 4 The simulated time development of nuclear workforce in the USA (Li, Dale et al. 2009).

### 3. FUTURE DIRECTIONS IN NUCLEAR EDUCATION AND RESEARCH

Slovenia with the population of 2 million is the smallest nuclear country in the world. The energy produced in the one nuclear power plant at Krško accounts for close to 40% of all electricity produced in the country. A single nuclear unit brings a complete responsibility for the safe operation of the nuclear power plant. The primary responsibility for safe operation is clearly with the operator. In addition to that, an independent regulatory body and well established education are required (IAEA 1996). Rather small population and a rather modest economy pose clear limits on the resources available for education and research. The limited resources and workforce globalization call for a rather proactive approach combined with extensive international cooperation in both research and education.

Recent status of Slovenian research and education activities related to the nuclear engineering and nuclear safety is available in (Cizelj 2010). The international research cooperation of the Jožef Stefan Institute and the Faculty of mathematics and Physics (University of Ljubljana) includes participation in the EURATOM framework programs of the European Commission (FP5, FP6 and FP7), participation in the joint projects of the OECD/NEA, a number of bilateral actions and active participation in the European sustainable nuclear energy technology platforms (SNETP) and association NUGENIA.

Ever increasing attention has been recently given to the international cooperation in the research based education. The Jožef Stefan Institute and the Faculty of mathematics and Physics (University of Ljubljana) have been among the founding members of the European Nuclear Education Network (ENEN) association, a non-profit association formed in September 2003 (under a French law dating from 1901) to ensure the highest possible quality of nuclear education and training. This legal entity, located at CEA-INSTN Paris, France, is currently composed of 64 members (universities, research organisations, industry) from 18 EU

Member States, Switzerland, South Africa, Russian Federation, Ukraine and Japan. The ENEN association, in synergy with the employers concerned, has a leading role in the above "Euratom Fission Training Schemes". The synergy of ENEN with national E&T networks and with the Technological Platforms plays also a key role in the Euratom E&T strategy.

The ENEN Association has developed a harmonized curriculum for the Master of Science in Nuclear engineering (Moons, Safieh et al. 2005). The already traditional activities to attract students include the yearly ceremonies celebrating new European Masters of Nuclear Engineering (EMSNE) and awarding the prizes for the best Ph.D. theses. The title of the EMSNE is given to acknowledge extensive mobility of M. Sc. students and is given to those who earn at least 20 ECTS (full academic year is 60 ECTS) with the members of the ENEN association abroad.

Currently, a substantial attention is given to the on-going analysis, findings and lessons learned from the Fukushima Daiichi accident. The impact on the scientific and technical parts of the curricula is expected to be moderate: the large part of the physical processes, which occurred there, have already been to a significant extent known before. The notable improvements may be however needed in better quantification of these processes and development of improved prediction methods. The most important changes in the curricula may call for more research and knowledge in social sciences, especially Communication and Safety culture. Interdisciplinary topics such as for example Emergency Response and Quality Control may also bring substantial benefits to the curricula in the near future.

#### 4. CONCLUSIONS

Research and research based education have been in the forefront of the peaceful use of the nuclear energy since the very beginning in the 1950-ies. The influx of young people in Europe and especially in the USA started to dwindle during the oil crisis in the 1970-ies and almost vanished after the Chernobyl accident in 1986. For more than two decades to follow, the nearly constant fleet of nuclear power plants was then managed by the gradually ageing workforce. The first warnings about the dwindling expertise and calls for imminent adjustments started at the end of 1990-ies.

The augmented concerns about education and research have been regularly perceived in the analysis of the accidents and have been raised up in the analyses of recent events, including the Fukushima Daiichi nuclear accident and the fatal crash of Air France flight 447 over the Atlantic in June 2009.

Recent analyses on the supply and demand for nuclear workforce in the European Union indicate that the current supply of nuclear graduates is only sufficient to replace up to 70% of the retirees from the existing workforce. The workforce may be even scarcer if the operational time of the current nuclear fleet is extended beyond 40 to 60 years. In addition, some countries are already building new nuclear power plants (Finland, France) and others have already clearly indicated intentions to do so (Lithuania, Czech Republic, Poland, Great Britain).

The best strategy for the world's smallest nuclear country Slovenia with rather limited resources may be a proactive approach combined with extensive international cooperation in both research and education. In addition, changes in the nuclear engineering curricula may be considered to improve knowledge in social sciences, especially Communication and Safety culture. Interdisciplinary topics such as for example Emergency Response and Quality Control may also bring substantial benefits to the curricula in the near future.

## REFERENCES

- Birkhofer, A., A. Alonso, et al. (2011). Never Again: An Essential Goal for Nuclear Safety. Statement.
- Bureau d'Enquêtes et d'Analyses pour la sécurité de l'aviation civile (2012). Final Report on the accident on 1st June 2009 to the Airbus A330-203 registered F-GZCP operated by Air France Flight AF 447 Rio de Janeiro-Paris. Paris, France.
- Burian, B. K., I. Barshi, et al. (2005). The Challenge of Aviation Emergency and Abnormal Situations, NASA.
- CCE Fission (2001). How to maintain nuclear competence in Europe: A reflection paper prepared by the CCE-Fission working group on nuclear education, training and competence, European Commission.
- Cizelj, L. (2010). RESEARCH AND EDUCATION IN NUCLEAR ENGINEERING AND SAFETY: A NATIONAL, REGIONAL OR GLOBAL ACTIVITY? Power Plants 2010. Vrnjačka Banja, Serbia, Society of Thermal Engineers of Serbia.
- EURATOM (1957). Treaty establishing the European Atomic Energy Community (EURATOM). Brussels, Belgium.
- Frederick, E. R. (1988). Design, training, operation: the critical links. An operator's perspective. International Symposium on Severe Accidents in Nuclear Power Plants. Sorrento, USA.
- IAEA (1996). Convention on Nuclear Safety I. A. E. Agency. Vienna, Austria.
- Li, N., C. Dale, et al. (2009). Los Alamos Nuclear Enterprise Resource and Infrastructure Model (LA-NERIM). ICAAP 2009. Tokyo, Japan: Paper 9322.
- Moons, F., J. Safieh, et al. (2005). »European Master of Science in Nuclear Engineering.« Nuclear Engineering and Design **235**(2-4): 165-172.
- OECD/NEA (2000). Nuclear education and training: cause for concern? NEA 2428.
- Simonovska, V. and U. v. Estorff (2012). Putting into perspective the supply of an demand for nuclear experts by 2020 within the EU-27 nuclear energy sector. JRC scientific and policy reports.
- Simonovska, V., U. v. Estorff, et al. (2011). »Great expectations.« Nuclear Engineering international May 2011: 44.45.
- The National Diet of Japan (2012). The official report of the Fukushima nuclear accident independent investigation commission NAIIC (Executive summary).





# Dr. Yasuyuki Shimizu, Japan



## Effects of the First Flood Control Plan and River Improvements on the Ishikari River Basin

Hokkaido University, Faculty of Engineering

E-mail: [yasu@eng.hokudai.ac.jp](mailto:yasu@eng.hokudai.ac.jp)

### ABSTRACT

About 150 years ago, Japanese Government launched the policy of encouraging migration to Hokkaido and started reclamation of the Ishikari River Basin. In September 1898, the Ishikari River was hit by an unprecedented heavy flood that resulting in catastrophic damage and 112 fatalities. Okazaki et al. made detailed investigations and observations on the 1904 flood. A flood control plan focusing on cutoff works was formulated, and those works were implemented for the half-century from 1910. This study reviews the effects of the flood in 1904 and the flood control plan by Okazaki et al. A two-dimensional numerical simulation model is used to examine the effects of cutoff works.

## 1. PURPOSE

Development of the Ishikari River Basin started when the Hokkaido Development Commission was established in Sapporo in 1871. Because of the aggressive immigration policy of the government, the population in the area increased to 300,000 by 1897. A large-scale flood, the worst in the history of the Ishikari River, occurred in September 1898. The damage was enormous: 112 people were killed and 19,000 houses were damaged in a flood whose water surface area was 41,000 *chobu* (406 km<sup>2</sup>). The Hokkaido Flood Investigation Committee was immediately established, and investigations were launched. As shown in Fig. 1, a flood on a scale similar to that of the 1898 flood occurred in 1904, during the time when the investigation by the committee was in progress. Bunkichi Okazaki and other members of the committee carried out flood observations according to plans they had prepared for such an occasion. Based on the observations, they set a design discharge and completed an investigation report in 1909. The Ishikari River Improvement Project of 1910 was initiated based on the report. The majority of the project involved the construction of shortcuts to straighten the meandering river. By the 1960's, the construction of shortcuts had been actively carried out. In the present study, we simulate the flood of 1987 based on the observation data of Okazaki et al. and compute the effects of the shortcuts constructed at the lower reaches during the early stages of the project by using a two-dimensional numerical analysis.

## 2. FLOOD OBSERVATIONS BY OKAZAKI ET AL.



Fig. 1. The 1904 flood in the Ishikari river basin.

As shown in Fig. 1, Okazaki et al. set benchmarks on the Ishikari, Uryu, Sorachi and Yubari rivers and observed the water level, discharge and the initial topography of the floodplain. A flood occurred on July 11, 1904 when Okazaki et al. were preparing for observations. They performed detailed observations even when river water overflowed the channel. The discharges for the surveyed cross-sections were estimated as shown in Fig. 2. The volume of flooded water between the two survey points was estimated based on the observed water levels for the surveyed hours and the results of topographic surveys, and the results of estimation are summarized in Fig. 3. An average flood discharge upstream of each survey point was obtained from this figure, and the observed discharges for the channel and floodplain were added to the

obtained value. The design discharge for the normal water level was obtained as 8,350 m<sup>3</sup>/s. This design discharge, obtained by Okazaki et al., had been used until its revision to 9,270 m<sup>3</sup>/s in 1965. The average flood discharge and the discharge for the channel and floodplain from 7:00 to 18:00 on the July 11, the peak of the flood, are shown in Fig. 4.

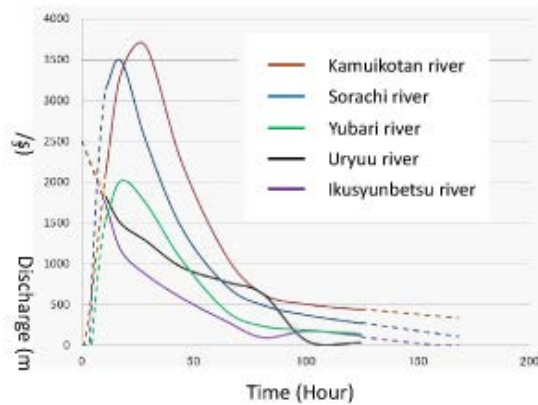

Fig. 2. Observed floodwaters from the rivers entering the floodplain.

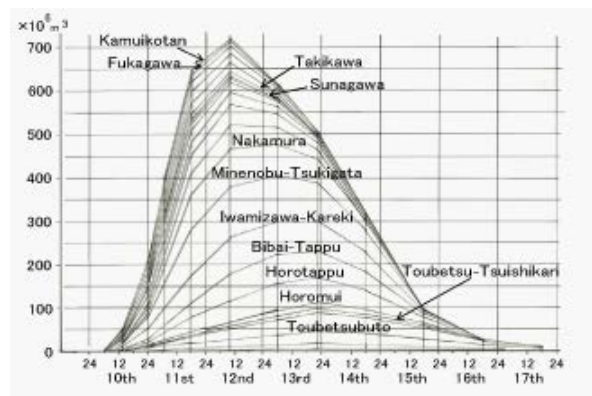

Fig. 3. Water in the river channel in the 1904 flood.



Fig. 4. Flows in the 1904 flood.

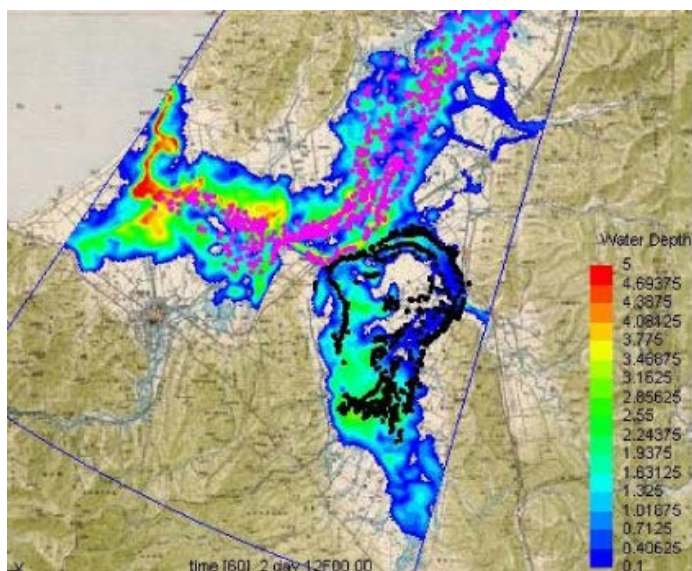

Fig. 5. Simulation of the 1904 flood.

### 3. SIMULATION OF THE 1904 FLOOD

The 1904 flood was simulated by using the discharge observed in 1904 (Fig. 2). The channel form of the Ishikari at that time was estimated based on the 1918 survey data and the present day survey data on the old channel. Simulation was done by two-dimensional computation. Present-day laser profiler data were used for determining the computation grid for the floodplain, with the grid size averaging 220m. The coefficient of roughness was set as 0.03 for the channel and floodplain. The computational result for 60 hours after the start of flooding is shown in Fig. 4. Particles are shown such as to differentiate between the main stream flows of the Ishikari River and the Yubari River, a branch of the Ishikari. From the particles one can see that the water of the Ishikari flows down with flooding, whereas the Yubari and Chitose rivers show flow stagnation, because they cannot mix into the flow of the Ishikari. The simulation shows the characteristics of the land on the two tributaries, whose elevations are lower than that of the main stream of the Ishikari.

### 4. EFFECTS OF SHORTCUT CONSTRUCTION

Improvement projects for the Ishikari River started with the construction of shortcuts. The purpose of the construction to shortcut the meanders of the Ishikari and to make the river bed gradient steeper was to increase the flow velocity during flooding, lower the water level and reduce incidence of water flooding out of the channel. Another expected effect of the shortcuts was that the lowered normal-time water level would lower the ground water level throughout the Ishikari Plain, which was widely distributed with peat and soft clay soil with high water content, and that this would enable the area to be cultivated. As shown in Fig. 6, shortcut constructions were planned at five locations on the lower reaches of the Ishikari. The construction of Oyafuru Shortcut at the lowest location was started in 1910 as the first flood control construction on the Ishikari. The engineers who carried out the construction of the Okozu Diversion Channel on the Shinano River, which was the most advanced construction project of the time, instructed the local engineers. A dredger boat was rented from the Tone River area in Chiba Prefecture. The first shortcut was opened in 1931. The other shortcuts constructed during the same period were opened by 1933. The channel length, which had been 46 km from the Ishikari's confluence with the Toyohira River to the river mouth, was shortened to 24 km, and the river bed gradient was increased to 1.9 times that of the original meandering river.

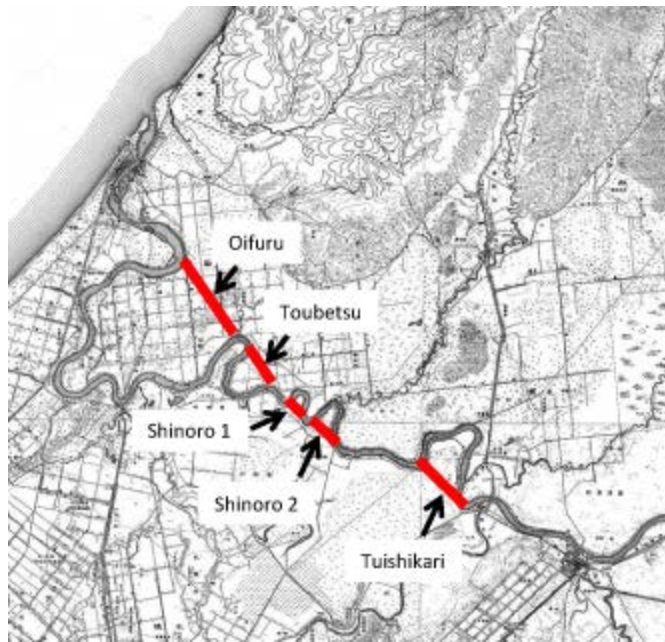

Fig. 6. Locations of shortcuts on the Ishikari River.

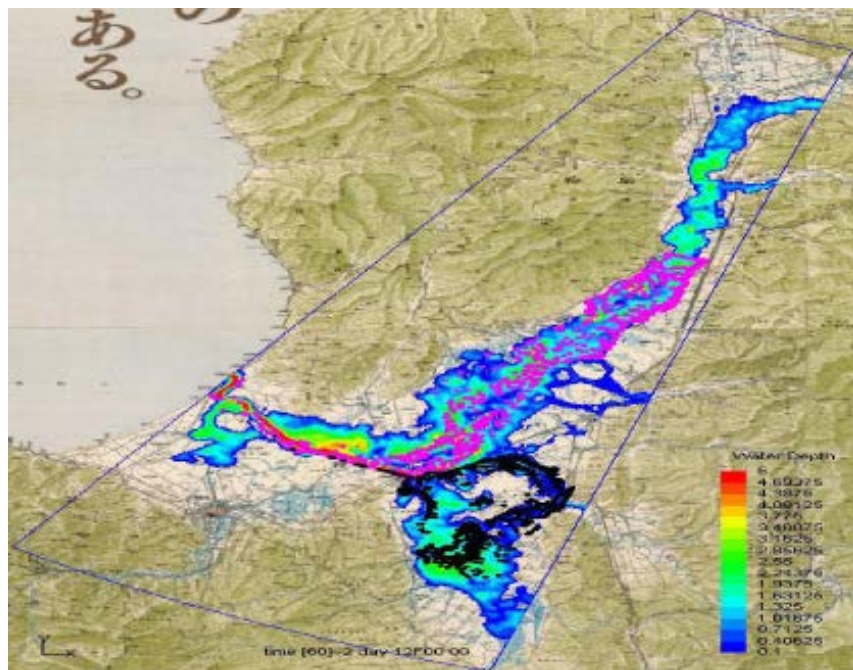

Fig. 7. Simulation of a flood after completion of the shortcuts.

To determine the effects of these shortcuts, the river channel after the completion of the project was simulated. The 1904 discharge was used in the computation. The simulated results for the same hour as that in Fig. 5 are shown in Fig. 7. No clear differences before versus after construction are observed in the floodplain upstream of the shortcuts; however, clear decreases are observed in the floodplain with the shortcuts. It is observed that the Yubari River and the Chitose River flow into the Ishikari without stagnation. The influence of the lowered water level at the Ishikari's confluences with the Yubari and the Chitose rivers are particularly great, because the elevations of the floodplains of these two rivers are lower than that of the upstream of the Ishikari. This analysis clarified that the flooding for the simulated time started in the upstream areas and gradually ran down to the lower reaches. It was also clarified that the flooded areas at the lower reaches started to expand after the flooded areas at the upstream reaches decreased.

## 5. CONCLUSION

It took one week for the 1904 flood to subside. According to the computational model simulation, it took long for the flooding to subside because the flooded water on the Yubari and Chitose rivers was retained until the water level of the Ishikari became low. It was also clarified that the shortcuts constructed in the early stages of the project had remarkable effects on reducing flooding in the Sapporo area and on decreasing the duration of flooding of the Yubari and the Chitose rivers. Now, a hundred years after the initiation of improvement projects on the Ishikari River, assessment of the effects of the shortcuts has become possible by digital computation. This study gave us an opportunity to know the accuracy of flood surveys in the Meiji Period and to recognize the foresight of the engineers of the time, who set a design discharge of 8,350 m<sup>3</sup>/s for the river with a channel capacity of 2,500 m<sup>3</sup>/s and who planned flood control measures consisting mainly of shortcuts.

286

## REFERENCES

- Hokkaido Development Association: History of Flood Control on the Ishikari River, 1980.
- Hokkaido Development Bureau: The Dawn of Flood Control on the Ishikari River -Footsteps of Bunkichi Okazaki-, 1990.
- Yamaguchi, H., Shinagawa, M. and Seki, H.: Shortcuts, 1996.
- Hokkaido Development Bureau: River Development Plan for the Ishikari River, 2010.
- Hokkaido River Disaster Prevention Research Center: In Honor of the Achievements of Eiichi Ariizumi, 1996.
- Kume, Y.: Flow of the Ishikari River, 2000.

# Prof. Dr. Matjaž Četina, Slovenia



287

MATJAŽ ČETINA

## Computations of Dam-Break Waves in Slovenia

University of Ljubljana, Faculty of Civil and Geodetic  
Engineering

E-mail: [matjaz.cetina@fgg.uni-lj.si](mailto:matjaz.cetina@fgg.uni-lj.si)

### ABSTRACT

Dams that were built to accumulate water for energy production, agriculture, water supply and other purposes are among most important and sophisticated engineering structures. Despite obeying high standards during their design and construction they represent a certain threat to villages and inhabitants living downstream. A state of the art review of dam-break wave and debris flow computations in Slovenia are given in the article. Among others three practical case studies are shown more into detail: simulation of dam-break waves in the chain of hydro power plants on the lower Sava River where also the nuclear power plant Krško is situated, a wave resulting from a potential dam-break of the upper storage reservoir of the planned pumping power plant Kozjak in NE Slovenia and computations of landslide initiated debris flow in Log pod Mangartom, NW Slovenia.

## 1 INTRODUCTION

Protection of inhabitants against floods is an important task of hydraulic engineers. Some recent developments of predictive tools that are used in Slovenia to simulate waves caused by dam breaks are presented in the article.

According to Goubet (1979) the probability of a dam-break event is very low, only 0.01 % per dam per year. But there are still several reasons why the potential danger of the collapse of dams is a very timely issue: a number of old dams existing for a long time, a large number of newly constructed dams, and more and more densely inhabited valleys below dams. In many countries all over the world and most of them in Europe determination of the parameters of the wave that would follow the collapse of an existing or a planned large dam is required by law in order to organise the defense of inhabitants and structures in the valley downstream.

In the period from 1970 to 1995, mostly one-dimensional (1D) mathematical models have been used in Slovenia for dam-break wave computations (Rajar, 1978). In cases where total and instantaneous collapse as the most dangerous situation is hardly possible (e.g. earth dams), partial and gradual dam collapse have been taken into account. The size and time development of the breach have been assessed in advance on the basis of experiences from past events. Most commonly statistical methods to determine the duration of a gradual collapse have been used (Costa, 1985; Molinaro, 1990).

To improve the accuracy of the results, some new approaches in the determination of hydraulic characteristics of dam-break waves have been used in Slovenia in the last 15 years. These improvements were initiated by our new legislation in this field passed in 1994 and can be summarized into three main points: (1) an attempt to improve the simulation of breach morphology caused by erosion, (2) the use of two-dimensional (2D) mathematical models in steep curved channels below dams and more downstream in enlarged areas of relatively flat and wide flood plains and (3) the use of denser numerical grids due to more powerful computers.

## 2 DESCRIPTION OF MATHEMATICAL MODELS

### 2.1 One-dimensional models

Flow in the reservoir and downstream of the dam is simulated by the well known St. Venant equations which are solved by the Lax-Wendroff explicit numerical method. To avoid numerical instability, additional eddy losses should be taken into account, especially in highly irregular natural valleys (Rajar, 1978). When simulating the flow over a partially or gradually collapsed dam, two cross sections are taken into account at the dam site. They are situated at the same location  $x$  while the third cross-section between them is the section of the collapsing dam. Its time development can be given in advance as the input data or can be simulated following the process of breach erosion. In the latter case at the initial time  $t = 0$  a small estimated breach is given as the input data. The velocities along the breach channel are computed with the assumption of steady uniform (usually supercritical) flow or optionally by a more exact computation of the water-surface profiles. It is assumed that the cross-sectional shape of the breach is trapezoidal at all times with constant side slopes and longitudinal slope of the breach. The bed level and width are computed by equations of the breach erosion process. The bed material transport is calculated by Einstein's relation where the dimensionless transport parameter is estimated by the formula of Engelund. When the bed material transport is known, the sediment continuity (Exner) equation is used to compute the time development of the breach channel morphology using the assumptions about its shape. More details can be found in Rajar and Zakrajšek (1991).



Following the principles described above we developed our own computer code LAXDEL (based on explicit numerical scheme) which is capable to simulate dam-break waves due to instantaneous and total or gradual and partial dam collapse. With the LAXDEL code almost all dam-break waves in Slovenia were computed. We developed also the computer code IMP2008 which uses an implicit numerical scheme to solve St. Venant equations. Some commercial codes that could be used for dam-break waves computations are: HEC-RAS 4.1 or higher (developed by US Army Corps of Engineers – USACE), MIKE11 (developed by Danish Hydraulic Institute) and RUBAR3 (developed by Hydrology-Hydraulics Research Unit of Irstea, former Cemagref, Lyon).

## 2.2 Two-dimensional models

Using Cartesian or curvilinear orthogonal coordinate systems continuity and momentum equations describing two-dimensional unsteady depth averaged flow are usually written in conservative form. The last two terms on the right hand side of the momentum equations expressing the influence of turbulent viscosity are in highly unsteady flows due to a dam collapse usually neglected but they have to be taken into account in some cases of flow with several recirculation zones (Četina and Rajar, 1993). The set of coupled partial differential equations is solved by the control volume based finite difference numerical scheme proposed by Patankar (1980). The main characteristics of the method are a staggered numerical grid, the combination of an upwind and a central-difference scheme (the so called hybrid scheme) and an iterative procedure of depth corrections (SIMPLE). A fully implicit scheme is used for time integration providing stable and accurate solution even at relatively high Courant numbers (up to about 10). It is possible to simulate both subcritical or supercritical flow (Četina and Rajar, 1993).

We developed our own computer codes PCFLOW2D for rectangular meshes (Četina and Rajar, 1994) and PCFLOW2D-ORTHO CURVE for orthogonal curvilinear meshes (Krzyk, 2004). Both computer codes have been used for dam-break wave computations in Slovenia more frequently during last 10 years and some applications are described in Chapter 3. For 2D flow computations also other commercial codes can be used: FLO-2D (Flo-2D Software, Inc., USA), MIKE21 (Danish Hydraulic Institute), AQUADYN (Synexus Global LTD., Canada), SMS (Boss International, USA) and RUBAR20 (Hydrology-Hydraulics Research Unit of Irstea, former Cemagref, Lyon).

## 2.3 Simplified two-dimensional models

In many practical flow situations (e. g. flood propagation over initially dry areas far enough from the site of the dam collapse) the terms expressing bottom friction and free surface slope prevail over the inertial terms. Following the basic idea of Xanthopoulos and Koutitas (1976) the inertial and turbulent viscosity terms in 2D momentum equations can be neglected. As a consequence, the dynamic equations are simplified to equations for steady nonuniform flows in  $x$  and  $y$  directions while the continuity equation is preserved in its original unsteady form. The flow domain is discretized by staggered orthogonal grid where depth averaged velocities are computed at the cell boundaries while water depths are determined at the cell centres. More details about the relatively simple finite difference explicit scheme used for the time integration can be found in Zakrajšek and Rajar (1996) where also the computer code XANTHO is described. XANTHO was used for some dam-break computations in Slovenia in the period from 1990 to 2000 when computers were not powerful enough to apply fully 2D models for such applications.

## 3 PRACTICAL APPLICATIONS

### 3.1 Dam-break waves on the Lower Sava River

#### 3.1.1 Description of the problem

Lower Sava River section is located in SE Slovenia in an environmentally sensitive region, because it is densely inhabited and because of a presence of a nuclear power plant (NPP) Krško in the region. Hydro energetic structures on the Lower Sava River despite all their advantages represent also potential danger to this region because of accumulated water volume and raised water level in the cases of unforeseen events (natural disasters, diversions, mistakes at the maneuvering). For that reason it is necessary to determine the extent of flood due to collapse of dams (Četina et al., 2008).

The basis for the calculations of hydraulic consequences of the collapse of hydro technical objects is the determination of starting points what damages can occur on these structures due to different causes. Usually these starting points are defined by the state regulations. However, these regulations are in Slovenia still in the phase of draft and therefore an expert commission was formed on the initiative of the financer of this project. This commission was composed of representatives of all the competences, which are in any way connected with this topic. It was agreed that the calculations for all the possible combinations of collapses are carried out at two initial conditions:  $Q_0 = 1200 \text{ m}^3/\text{s}$  and  $Z_0 = Z_{\text{nom}}$  and  $Q_0 = Q_{25}$  and  $Z_0 = Z_{\text{nom}} - 1 \text{ m}$ . It was also agreed that for each dam in the chain we shall verify which initial conditions cause the most dangerous results and then we treat all the cases only with this discharge. However, later on we found out that the most dangerous results can be obtained with any of the initial discharges. Therefore we carried out all the calculations at both initial conditions.

Due to the US regulation ANSI/ANS-2.8-1992, valid for NPP Krško, we also carried out the calculation of the consequences of the collapse of all the three dams on the Upper Sava River (Moste, Mavčiče, Medvode). Regarding the fact, that we could not make the detailed analysis of the collapse of the three dams, it was agreed that we make a superposition of the waves that would be caused by a single dam to the initial discharge before the collapse  $Q_{25}$  and we make the calculation of the wave propagation from hydro electric power plant (HEPP) Medvode to HEPP Vrhovo and then further on in the region of the Lower Sava River. Regarding the demand of the representative of NPP Krško we introduced also the evaluation of rising of the water level due to the effect of wind.

#### 3.1.2 Methodology of computations

For the calculation of all cases of dam break wave, we used 3 mathematical models. For the calculations of dam break wave propagation we used 1D mathematical model IMP2008. For the calculation of propagation of the discharge which would overflow the side embankments and would flow over the flood plains and would return back to Sava downstream of each HEPP we used 2D mathematical model PCFLOW2D. For calculation of the dam break wave for HEPP Moste, HEPP Mavčiče and HEPP Medvode on the section HEPP Moste – HEPP Vrhovo we used mathematical model HEC-RAS. Locations of HEPP on the Sava River are shown in Figure 1

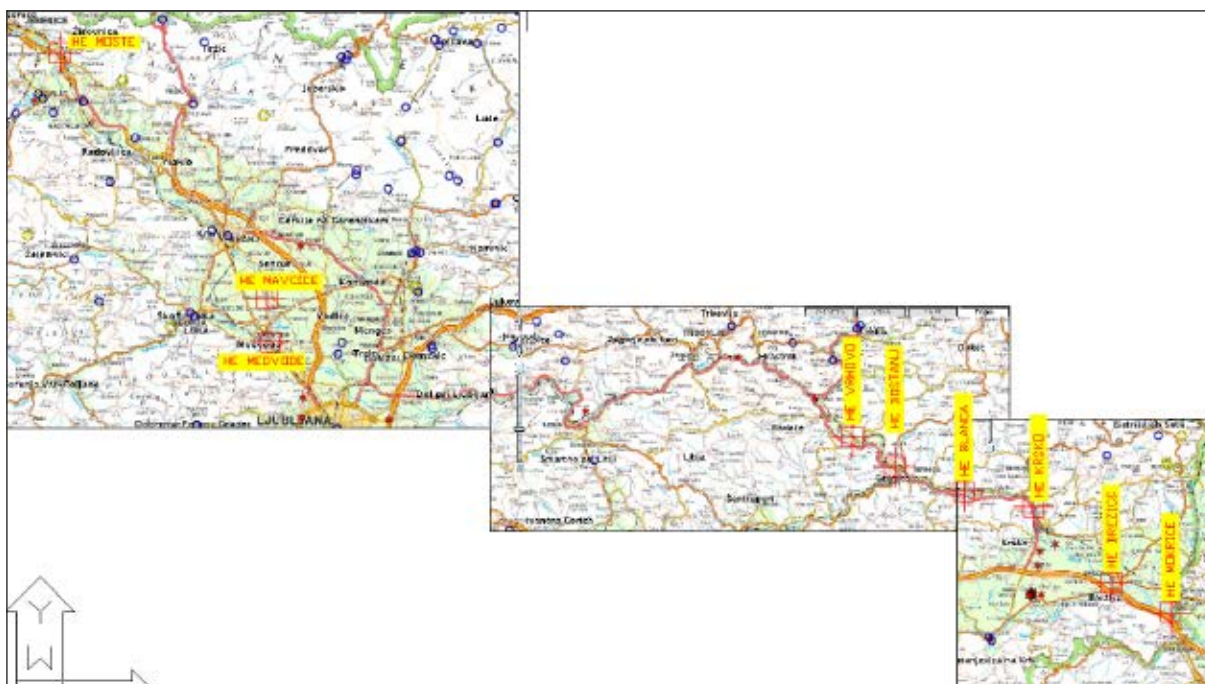

Figure 1: Overview situation of the Sava River in Slovenia with locations of HEPP.

### 3.1.3 Results

At the partly finished chains of HEPPs the flooding of the downstream regions in the present state is essentially greater at the basic discharge  $Q_{25}$  than at the discharge  $1200 \text{ m}^3/\text{s}$ . The dam break waves at  $1200 \text{ m}^3/\text{s}$  cause in all reservoirs in the present state essentially lower levels than the  $Q_{100}$  flood wave. The dam break waves at  $Q_{25}$  will cause in all reservoirs lower level than the  $Q_{100}$  flood wave. Only in Brežice reservoir along a shorter section the level is higher up to  $0.25 \text{ m}$ .

For the planned state more dangerous are the cases of collapse of single dams at the basic discharge  $1200 \text{ m}^3/\text{s}$ , especially if the segments on the downstream HEPP are blocked at the initial opening which does not allow conveyance of full natural discharge. If it was assured to remove at least one segment on each HEPP the problem would be solved.

Influence of wind can cause additional rise of the water level of about  $0.12 - 0.41 \text{ m}$ .

In reservoirs Brežice and Mokrice overflow of a part of dam break wave over the side weirs will cause very fast flooding of flood plains – some protective measures should be taken into account. Also the dam break waves themselves will cause very fast changes of discharge and water levels in the bed and in flood plains and are dangerous even if they do not cause extensive floods.

The most dangerous flooding would be caused by the wave resulting from collapse of the 3 Upper Sava River dams at the basic discharge  $Q_{25}$ . The lowering of the peak discharge  $Q = 9950 \text{ m}^3/\text{s}$  below HEPP Medvode at different locations downstream on the Sava River is shown on Table 1. From Table 2 the discharges of the calculated dam break wave on the Lower Sava River can be seen. In the reservoirs of HEPP Boštanj, HEPP Blanca and HEPP Krško the water levels of the dam break wave are between levels of  $Q_{100}$  and  $Q_{1000}$  in the present state. In the Brežice reservoir the level is mostly  $0.1 - 0.4 \text{ m}$  higher of the  $Q_{1000}$  levels, in the Mokrice reservoir the water level is mostly below the  $Q_{100}$  level, locally up to  $10 \text{ cm}$  higher, below HEPP Mokrice up to  $10$  over the  $Q_{100}$  level.

Location	km	$Q_{25}$ (m <sup>3</sup> /s)	$Q_{MAX}$ (m <sup>3</sup> /s)	$Q_{max}$ over $Q_{25}$ (m <sup>3</sup> /s)	Time of propagation of $Q_{max}$ from Medvode
Below HE Medvode	863890	1380	9950	8570	
Above the weir at Tacen	859071	1380	4271	2891	33 min
Below railway bridge in Črnuče	853163	1380	3601	2221	1 h, 39 min
Under Ljubljana inflow	841659	1910	3690	1780	3 h, 27 min
At street bridge in Litija	814255	1910	3088	1178	7 h, 3 min
Below the Savinja inflow	784985	2700	3727	1027	9 h, 42 min
Above HEPP Vrhovo	778170	2700	3720	1020	10 h, 6 min

Table 1: Attenuation of the wave due to successive collapse of dams Moste, Mavčiče and Medvode.

Location	$Q_{25}$ (m <sup>3</sup> /s)	$Q_{max}$ (m <sup>3</sup> /s)	$Q_{max}$ over $Q_{25}$ (m <sup>3</sup> /s)
Beginning of HEPP Vrhovo reservoir	1910	2939	1029
HEPP Vrhovo	2765	3786	1021
HEPP Boštanj	2765	3772	1007
HEPP Blanca	2765	3748	983
HEPP Krško	2765	3712	947
HEPP Brežice	2765	3636	871
HEPP Mokrice	3068	3924	856
V.P. Jesenice	3068	3918	850

Table 2: Discharges of the calculated dam break wave on the Lower Sava River.

### 3.2 Dam-break flow below the Kolarjev vrh reservoir

#### 3.2.1 Description of the problem

In this application (Krzyk, 2004; Krzyk et al., 2012) hydraulic aspects of a wave, emerging as a result of a potential dam break of the upper storage reservoir at the Kolar's peak (Kolarjev vrh, NE Slovenia) of the pumped-storage hydropower plant were investigated. To solve the problem simultaneous use of both, physical and mathematical models were used. Measurement results of unsteady flow on the physical model provided the basis for verifying the mathematical model PCFLOW2D-ORTHO CURVE.

The planned installed power of the pumped-storage hydro power plant (HPP) Kolarjev vrh is 300 MW, with the height difference of up to 714.70 m, depending on the water levels in both storage reservoirs. The installed turbine flow would be 51 m<sup>3</sup>/s and the pumps would have a discharge of 37 m<sup>3</sup>/s. The upper storage reservoir would be connected to the powerhouse with a pressure penstock 2660 m long and 3.0 to 3.5 m in diameter. As the lower storage reservoir of the pumped-storage HPP Kolarjev vrh, the existing storage reservoir of HPP Fala on the Drava River would be used. At the Water Management Institute in Ljubljana, a physical model of the upper storage reservoir was made, together with the valley lying to the south in the scale of 1 : 200 (Legiša and Rajar, 1980).

The upper storage reservoir would be located on the flattened Kolarjev vrh. The level of the reservoir bottom would be at 975.00 m a. s. l., with maximum dimensions of  $350 \times 750$  m. The storage reservoir would comprise an area of 160 000 m<sup>2</sup>. The bank slope on the inner side of the storage reservoir would be approximately 1 : 2, and on the outer side 1 : 1.5. The crest elevation would be 996.50 m a. s. l., 1.5 m above the highest water level in the upper reservoir (995.00 m a. s. l.) and would have a width of 5 m. The water volume in the reservoir would be approximately  $2.8 \times 10^6$  m<sup>3</sup>. The measurement results at 6 gauges were used for the verification of the mathematical model PCFLOW2D, which was used for hydrodynamic modelling of flow in the upper reservoir.

Since the physical model was made only to facilitate the verification of results of the mathematical model, only the shortest, south valley of the Logar's Creek (Logarjev potok) was built. The part of the dam gravitating to the valley is approximately 1 km long. The length of the waterway spilling from the reservoir to the town of Selnica lying approximately 700 m below is 6 km, of which 4500 m are represented by a fairly narrow valley that passes into the wide valley of the Drava River. To verify the results of the mathematical model PCFLOW2D-ORTHO CURVE, data relating to the narrow part of the valley were used. In the physical model, the analysis of the dam-break wave caused by an instantaneous break of part of the dam was performed. Several possible widths of a dam break were considered, namely 48 m, 99 m, 237 m and 433 m. The length of the flow under study was 4620 m, and the head difference between the reservoir bottom (975 m a. s. l.) and the more flat part of the valley was 646 m. The average channel slope was 14 %. In order to monitor the motion of the wave and its characteristics on the physical model, six gauges were set up in the upper part of the valley and six in the lower part of the valley. For the purpose of this study, only the results of the first five gauges are of interest, because other gauges were positioned outside the area covered by the mathematical model. The measurements gave the propagation time of the wave front to each gauge and water depth oscillation at each gauge.

### 3.2.2 Computational details

In the reservoir the size of the numerical mesh was  $\Delta x = \Delta y = 4$  m and the time step was  $\Delta t = 0.5$  s. On the basis of measurements conducted on the physical model of the downstream valley, it was estimated that it would be appropriate to monitor the time of wave propagation across the valley up to about 400 s after the demolition of the dyke. Therefore, maximum computation time of 420 s was chosen. Boundary conditions used in the mathematical model of the reservoir were as follows: flow velocities through reservoir dykes were zero and at the site of the dam-break, critical flow was assumed at each cell. The sum of discharges through drainage cells represented the total outflow in the profile of the destroyed part of the dyke. As the initial condition in the reservoir, water level at  $Z = 995$  m a.s.l. was assumed. The initial width of the collapsed part of the dam was 237 m.

In the initial stage of calculation, the downstream valley is dry. To meet this condition in the mathematical model, low water depth was given at the beginning of calculations. We chose a minimum level of 5 cm and all cells with water depth lower than 5 cm were considered dry with flow velocity equal to 0. Lower initial depths resulted in instabilities in the calculation, probably due to the high terrain gradient. Based on the actual conditions, where the wave would propagate with a depth of 15 to 20 m, the chosen initial depth of 5 cm was considered negligible and thus acceptable. The minimum depth was also lower than the expected accuracy of calculations. The inflow and outflow boundary conditions had to be defined separately. The inflow curve  $Q-t$  was adopted in the model, which was the result of previous calculations of the flow in the reservoir during partial dam break. In the initial time, the discharge was 46947 m<sup>3</sup>/s, which was determined theoretically. In the lower (outflow) boundary of the model, the critical depth was defined as a boundary condition. Due to the high channel slope, however, this boundary condition did not have any impact on the upstream flow. The friction coefficient of the downstream valley was determined by considering the basic laws governing flow in steep channels. One of the basic observations was that the value of Manning's coefficient was not a constant and that it depended on several parameters. By using the Rickenmann's

equation (Rickenmann, 2000) and several simplifications, the dependence between the Manning's friction coefficient and bed slope was established.

### 3.2.3 Results

A comparison between the measured water depth versus time curves at different gauges and the calculated depths was made during the calibration of the mathematical model, where different values of the mean friction coefficient  $\bar{n}$  (0.040, 0.045 and 0.050 s/m<sup>1/3</sup>) were used. The comparison for the last, downstream gauge 5 is shown in Figure 2. For the average value of the Manning's friction coefficient  $\bar{n} = 0.050$  s/m<sup>1/3</sup>, a very good correlation of maximum depth was established, as well as the propagation time of the wave to the measuring site, even if the path of the calculated wave did not coincide perfectly with the measured one. Figure 3 provides an axonometric view of the water surface along the channel at the moment of the wave approach to gauge 5.

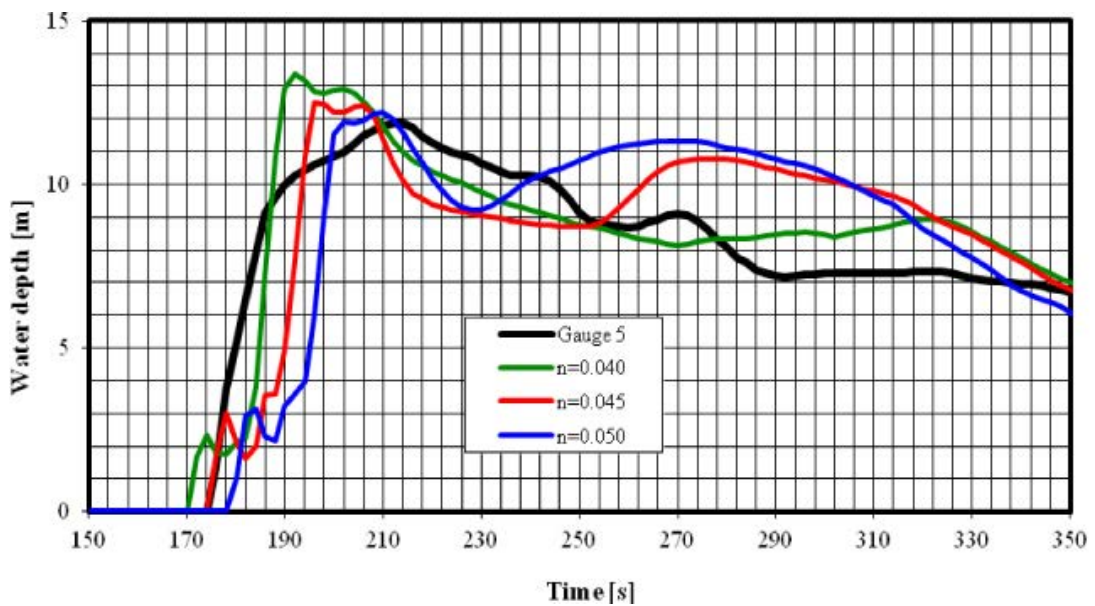

Figure 2. Measured and calculated water depths at gauge 5 with different friction coefficients.

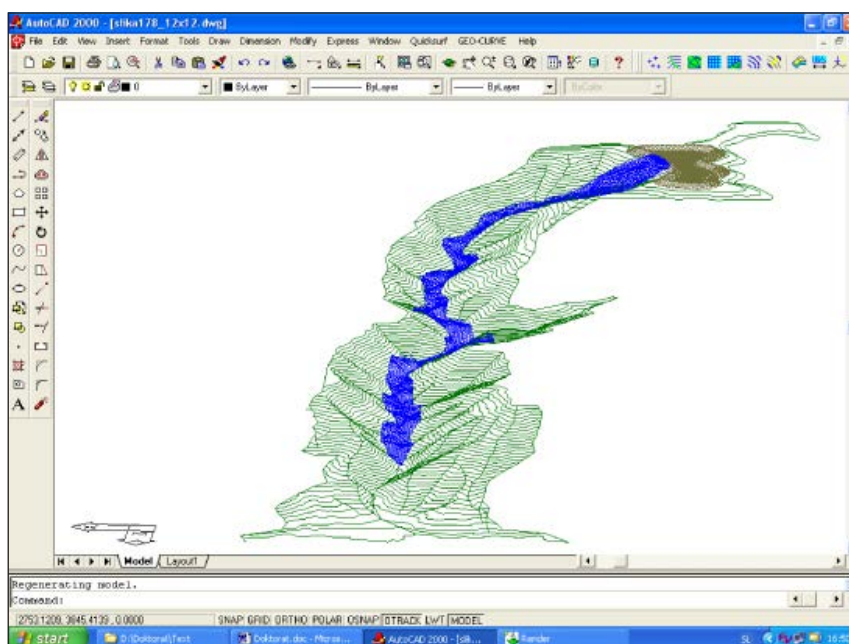

Figure 3. View of the wave 178 s after the dam break (approach of the wave front to gauge 5).

### 3.3 Modelling of debris flow at the village Log pod Mangartom

#### 3.3.1 Description of the problem

In Slovenia, almost one third of the country area is covered by slopes, which are conditionally stable due to their unfavorable geological composition. They are often threatened by landslides, initiated e.g. by heavy rainfalls and sometimes by earthquakes (Mikoš and Fazarinc, 2000). After a landslide/debris flow in November 2000, which caused a great damage and seven lives lost in the village Log pod Mangartom (Mikoš et al., 2004), a numerical study was carried out. Its main goal was to predict inundation limits for potential future landslides and to determine the effect of different protective measures (Četina et al., 2006).

Due to prolonged heavy rain, on November 15<sup>th</sup>, 2000, a landslide – debris flow glided down the slope of Stože, NW Slovenia (Figure 4). The mass mostly stopped at Bridge I, just some percent of the mass flew over the bridge (Reach A, Figure 4). During the next two days the mass was moistened continuously by heavy rain and by the inflow of the Mangart Creek. Just after midnight of November 17<sup>th</sup>, a smaller additional landslide glided down the slope and triggered the very wet mass of the first landslide into a debris flow. The combined mass overflowed the bridge, completely erasing it, and flew down the narrow canyon of the Predelica Torrent (Reach B, Figure 4). In about 4 minutes (front velocity about 15 m/s) it reached the village Gorenji Log (Reach C, Figure 4), where it killed 7 people in their homes, destroyed 6 and severely damaged 23 residential or farm buildings. The aerial photograph on Figure 5 shows the devastated Reach C.

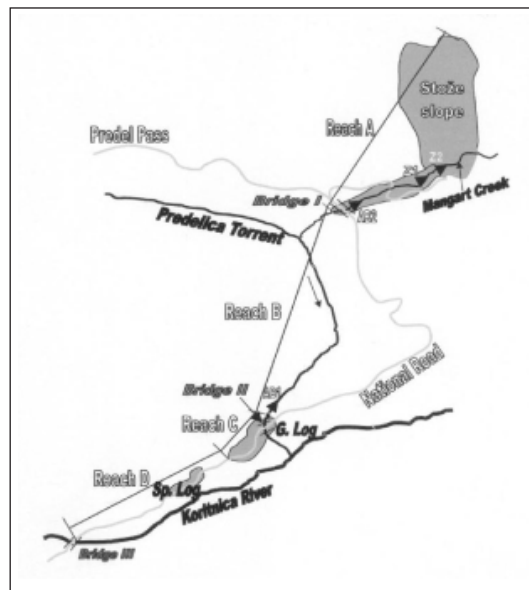

Figure 4. Situation of the village Log pod Mangartom and computational reaches of debris flow.

#### 3.3.2 Methodology of computations and mathematical models used

The phenomenon of mud/debris flow is similar to unsteady flow of water, in particular to the dam-break flow, and even more to snow avalanche dynamics (Rajar, 1980; Takahashi, 2001). In all these cases the flow is governed by the physical laws of conservation of mass and of momentum. However, it is well known, that the resistance to flow movement is more complex in debris flows and snow avalanches than in pure water flows (Takahashi, 2001). The rheological behavior of the flow depends in a great extent on the debris flow sediment/water concentration. This can vary from nearly dry landslides to debris flow, mud flood and purely water flow.

The total shear stress in the mud/debris flow is most often classified roughly in four components (Takahashi, 1997): (1) yield stress which is defined as the sum of cohesive strength and the Mohr-Coulomb shear and

must be exceeded to initiate motion; (2) solid-liquid viscous shear stress; (3) mixture's dispersive stress due to frictional contacts and collision of solid particles; (4) turbulent shear stress due to channel boundary roughness. Which of the above described terms are important in the flow resistance, depend on the flow regime. Several classifications of flow regimes are described in the literature. Takahashi (1997) describes the following flow regimes: (1) Quasi-static regime; (2) Macro-viscous flow regime; (3) Grain-inertia flow regime; (4) Turbulent flow regime.

Most authors describe each type of the shear stress by a different resistance formula. There are a number of different formulations available in the literature. Takahashi (1997) proposes different resistance equations for each of the four above described flow regimes. However, in practice the flow regime is usually not known in advance. The sediment concentration, and with it the flow regime, often changes along the debris path, as additional sediment is scavenged and taken into the flow and/or additional water enters the debris flow. To avoid this problem a quadratic shear stress model was proposed by O'Brien et al. (1993) which was used also in our study. The model includes three terms, describing together the shear stresses, which dominate the mud/debris flows.

After visiting the devastated region a day after the debris flow event it was clear that the flow on some reaches (Figure 4) was mostly one-dimensional (1D) and along some other reaches was typically two-dimensional (2D). Therefore, three numerical models were applied: a 1D model DEBRIF1D (which is a variant of the model LAXDEL for Non-Newtonian fluids) along Reaches A, B, D and 2D models PCFLOW2D and FLO-2D along Reach C. Connections between subsequent reaches were done with calculated hydrographs at the end of each upstream reach. Models DEBRIF1D and PCFLOW2D were developed at the Faculty of Civil and Geodetic Engineering, University of Ljubljana, while FLO-2D is a commercial model, developed at the FLO Engineering, Inc., USA (FLO Engineering Inc., 1999).

### 3.3.3 Calibration process, simulations and results

Calibration of 1D and 2D models was made by finding proper values of rheological parameters  $\tau_y$  (yield shear stress of the sediment-water mixture),  $\eta$  (dynamic viscosity of the mixture) and  $n_g$  (Manning's roughness coefficient). We used three possible methods for determining these values: (a) values available in the literature; (b) results of geo-mechanical laboratory measurements (Majes et al., 2002); and (c) values obtained by the calibration of the model – comparison with the field measurements.

First landslide along Reach A (November 15<sup>th</sup>, 2000) was relatively dry and it stopped on a slope of 16%. The one-dimensional model simulated this phenomenon with the values of  $\tau_y = 2\,000\text{ N/m}^2$ , and  $\eta = 156\text{ Pa}\cdot\text{s}$ . Very wet debris flow along Reach B (November 17<sup>th</sup>, 2000), was calibrated with the values  $\tau_y = 20\text{ N/m}^2$  and  $\eta = 40\text{ Pa}\cdot\text{s}$ . Since Reach B is a very steep, narrow canyon, with the average slope of 17 %, and maximum slope of 119 %, the Manning's coefficient changed in broad limits from 0.03 to  $0.35\text{ sm}^{-1/3}$ . The greatest values were found along the steepest parts of Reach B, where the flow must have been similar to a waterfall. The longitudinal profile of simulated and measured maximum debris flow surface elevations along upper part of Reach B showed acceptable agreement. Similar accuracy was obtained also for Reaches A, C and D. Along Reach C, the comparison of measured and simulated inundation limits obtained by 2D models PCFLOW2D and FLO-2D is shown in Fig. 5. Calibrated debris flow values along Reach C were  $\tau_y = 20\text{ N/m}^2$ ,  $\eta = 10\text{ Pa}\cdot\text{s}$  and  $n_g = 0.05\text{ to }0.065\text{ sm}^{-1/3}$ . The comparison of the maximum debris flow elevations computed by PCFLOW2D and FLO-2D models as well as the comparison with the measured elevations, obtained by the inundation limits on November 17<sup>th</sup>, 2000 has shown that the accuracy of both models is satisfactory.

Based on detailed geological, hydrologic, and geo-mechanical analyses, it was determined that above the region of the last landslide on the Stože slope, there are potentially unstable masses and that in the future there is a potential danger of further landslides of the same or even greater extent as that in November 2000. Among experts it was agreed that the village should be protected against the same magnitude of



landslide mass as that of November 2000, when the total displaced volume was 1 200 000 m<sup>3</sup>. In the original landslide event, about 400 000 m<sup>3</sup> were deposited along Reaches A and B, while in the future only a deposition of 200 000 m<sup>3</sup> can be expected, as the bed is partially filled with the material of previous landslides and thus a volume of 1 000 000 m<sup>3</sup> would reach the village. To estimate the potential danger, other simulations were also done for possible initial volumes of 2.0 mio, 1.6 mio, and 0.8 mio m<sup>3</sup>. A series of simulations was also done with the initial volumes reduced by 600 000 m<sup>3</sup>. This would be approximately the retention volume of four possible dams.

Several variations of the terrain excavation and along stream walls at Reach C were taken into account in the simulations, to determine the most cost-effective solution to protect the village Log pod Mangartom. Removal of the debris mass, deposited during the previous debris flow, in fact maximum technically feasible increase of Predelica Creek conductivity and construction of some along stream protective walls was proposed as the most effective measures. Construction of four dams showed too low cost-effectiveness and has been dropped (Četina et al., 2006).

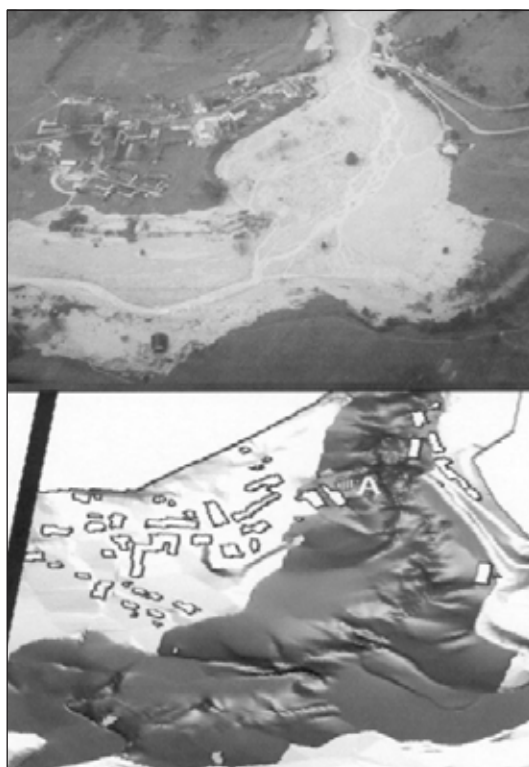

Figure 5. Comparison of observation and simulation. Up: aerial photography of debris flow area at Gorenji Log (photo: B. Vlaj, 22 Nov. 2000); Down: envelope of maximum levels from numerical simulation of the real event; A – house which was totally washed away.

#### 4 CONCLUSIONS

1D mathematical models for dam-break flow simulations which have been intensively used in Slovenia during the last 40 years have successfully replaced more expensive physical models. In the last 15 years, due to fast development of more powerful computers and advanced numerical techniques it is possible to use even more sophisticated approaches: simultaneous breach erosion simulation in combination with 1D models, 2D modelling of wave propagation over flood plains and debris flow simulations of Non-Newtonian fluids. In our further work we intend to continuously increase the accuracy of practical flow computations and to link the computer codes to user friendly interfaces for data input and graphic presentation of the results. The connection between mathematical models and Geographic Information Systems (GIS) could also be very helpful for mapping the flooded area.

## REFERENCES

- Costa, J. E. (1985). Floods from Dam Failures, U. S. Geological Survey, Report 85-560.
- Četina et al. (2008). Interacting influence of infrastructural and energy objects on the Lower Sava River during exceptional hydrologic events – Model of the Sava River – dam collapse waves, Final report (No. FGG\_2\_8789-CK). University of Ljubljana, Faculty of Civil and Geodetic Engineering.
- Četina, M., Rajar, R., Hojnik, T., Zakrajšek, M., Krzyk, M., Mikoš, M. (2006). Case study: Numerical simulations of debris flow below Stože, Slovenia. *J. hydraul. eng. (New York, N.Y.)*, 2006, vol. 132, iss. 2, pp. 121-130.
- Četina, M., and Rajar, R. (1994). "Two-Dimensional Dam-Break Flow Simulation in a Sudden Enlargement" *Proc. of the Int. Conf. Modelling of Flood Propagation over Initially Dry Areas*. P. Molinaro & L. Natale, eds. Milan, Italy, pp. 268-282.
- Četina, M., Rajar, R. (1993): Mathematical simulation of flow in kayak racing channel, *Proc. of the 5<sup>th</sup> International Symposium on Refined Flow Modelling and Turbulence Measurements*, Paris, France, 7. - 10. 9., ed. P.L. Viollet, pp. 637-644, ISBN 2-85978-202-8.
- FLO Engineering Inc. (1999). FIO-2D, Users Manual, Version 99.1. Civil and Water Resources Eng..
- Goubet, A. (1979). Risques associés aux barrages, La Houille Blanche, No.8, p.35.
- Krzyk, M., Klasinc, R., Četina, M. (2012). Two-Dimensional Mathematical Modelling of a Dam-Break Wave in a Narrow Steep Stream, *Journal of Mechanical Engineering* 58(2012)4, 255-262.
- Krzyk, M. (2004). Two-dimensional mathematical modelling of flow in steep streams (in Slovene with extended abstract in English), *Ph.D. Thesis, Univ. of Ljubljana, Faculty of Civil and Geodetic Eng.*
- Legiša, D., Rajar, R. (1980). Hydraulic model of the wave due to possible dam-break of the Kolarjev vrh reservoir (HPP Kozjak), *Report (in Slovene), Water management institute (VGI) and Faculty of Civil and Geodetic Engineering (UL FGG), Ljubljana*, 28 p., 6 Photographs, 32 Charts.
- Majes, B., Petkovšek, A., and Logar, J. (2002). Landslide Stože - Consequences and Feasibility of Corrective Measures. Proceedings of the 12<sup>th</sup>. Danube - European Conference. Passau, May 27-28, pp. 235 - 238.
- Mikoš, M., Četina, M., Brilly, M. (2004). Debris flow disaster in the village of Log pod Mangartom, Slovenia: First analysis of the event. *Engineering Geology*, 73 (3/4), pp. 193-213.
- Mikoš, M., Fazarinc, R. (2000). Earthquake-induced erosion processes in two alpine valleys in Slovenia. *Proc. of the Int. Symp. INTERPRAEVENT (Villach, Austria)*, Vol. 2, eds. F. Zollinger & G. Fiebiger, pp. 143-154.
- Molinaro, P. (1990). Statistical Methods for the Estimate of the Peak Discharge Following the Breach of an Earth Dam, Internal Report ENEL-CRIS, Milan, Italy.
- O'Brien, J.S., Julien, P.Y., and Fullerton, W.T. (1993). Two-dimensional water flood and mudflow simulation. *J. Hyd. Eng.* 119(2), pp. 244-261.
- Patankar, S.V. (1980). Numerical Heat Transfer and Fluid Flow, *McGraw-Hill B. C.*
- Rajar, R., Zakrajšek, M. (1991). Modelling a Real Case of a Landslide-Created Dam Collapse, *24th AIRH Congress*, Tokyo, Japan, Proceedings, B-4-1, pp. 109-116.
- Rajar, R. (1980). Mathematical models for simulation of flood waves, dam-break waves and snow avalanches. *INTERPRAEVENT*, Bad Ischl, pp. 232-134.
- Rajar, R. (1978). Mathematical Simulation of Dam-Break Flow, *Journal of the Hydraulics Division*, July 1978, HY7, pp. 1011-1026.
- Rickenmann, D. (2000). Dynamics of sediments and water in alpine catchments – processes and prediction, *Scientific report WSL, Birmensdorf*.
- Takahashi, T. (2001). Mechanics and simulations of snow avalanches, pyroclastic flows and debris flows. *Spec. Publ. Int. Ass. Sediment*, 31, pp. 11-43.
- Takahashi, T. (1997). Dynamics of the Inertial and Viscous Debris Flows. *Recent developments on debris flows, Lecture note in earth sciences*. Springer, pp. 117-143.
- Xanthopoulos, T., Koutitas, C. (1976). Numerical Simulation of a Two-dimensional Flood Wave Propagation Due to Dam Failure. *Journal of Hydraulic Research* 14, No.4.
- Zakrajšek, M., Rajar, R. (1996). 2D Modelling of Flood Waves: a Case Study, *18<sup>th</sup> Conference of the Danube Countries*, Graz, 26.-30. 8., Proceedings, Bd. 9, pp. B-153 – B-158.

# Dr. Syunsuke Ikeda, Japan



299

SYUNSUKE IKEDA

## Computations of Dam-Break Waves in Slovenia

Recovery and Job Development in the Aftermath  
of the Great East Japan Earthquake Disaster – The Situation  
after One Year of the Disaster

E-mail: [sk-ikeda@ctie.co.jp](mailto:sk-ikeda@ctie.co.jp)

### ABSTRACT

The Great East Japan Earthquake Disaster caused extreme damage to extensive areas. There is geographical diversity in the affected areas with its own characteristics in industrial structures. Recovery efforts should proceed with the industrial development and employment promotion taking account of the regional background. In light of this, this paper presents optimized recovery schemes to create job opportunities for three regions, namely, Sanriku, Sendai, and Fukushima. Furthermore, in view of the fact that there is manpower issue of engineers required for the recovery scheme, it examines measures to maintain supply of engineers.

## INTRODUCTION

The Great East Japan Earthquake caused extreme damages at wide areas. The major statistics are: dead and missing persons 19,225, broken houses 368,587, total loss of infrastructures 210 billion US dollars. The magnitude of the earthquake was 9.0 which is historically the 4<sup>th</sup> largest record in the world. Subsidence of lands along sea coast is about 0.8m~1m. Houses and infrastructures were damaged not by the earthquake itself but by tsunami. The tsunami yielded huge amount of about 22.5 millions tons of debris, which also makes the recovery difficult, 340 thousands of people are still evacuated from their houses.

The damaged areas can be divided into three by the types of disasters as follows:

1. Sanriku area where the geographical feature is saw-tooth type of coastline, and has been repeatedly suffered from the disaster of tsunami. Due to the geographical feature, the residential area is limited, and fishing and the processing are the major way of livings.
2. Sendai plain is agricultural area where 47.6% of farmlands were inundated by tsunami. Another industry is the parts-production of electronics and automobiles. The supply chains of the industries were severely damaged.
3. Fukushima area was also suffered from tsunami disaster, especially the subsequent melt-down of nuclear power plants induced huge damages around them. The area was widely polluted by radio-actives, and 163 thousands of people are still evacuated from their houses.

## PROCESSING OF DEBRIS AND RAISING OF LANDS

Processing of debris and raising of lands subsided by the movement of crust are the necessary condition for the recovery. The total amount of debris produced by tsunami is 22.5 million tons, among which Miyagi prefecture occupies 70% of them. For example, the ability for processing at Ishinomaki city, Miyagi, needs more than 100 years to finish the processing by themselves. At present, 70% of debris were removed. However, the final processing finished is still 5.6 %. This strongly suggests the need of support by other areas of Japan. However, the acceptance by other local government is still limited due to the rumor of radioactive contamination included in debris. The contamination is limited in the east part of Fukushima, and the government is required more effort to inform the truth to the publics. The government plans to finish the processing until March 2014.

As written previously, subsidence occurred in the area along the sea coasts, and raising of lands is necessary (Fig. 1).



Fig. 1 Subsidence of lands, Kesenuma

## RECOVERY OF PUBLIC INFRASTRUCTURES AND INDUSTRIES

The major infrastructures are almost recovered. Regarding transportations, roads are 100%, airport 100%, railways 99%, harbors 73%, river levees 82%. For lifelines, electricity 96%, gases 86%, tap water 98%. The public services are also almost recovered. Hospitals 81%, schools 100%, banks 85%, gas stand 85%, telephone 99%, mail service 89%.

The recovery of mining and manufacturing industries such as cars, electronics is also good and has reached 90%. However, the damage for agriculture and fisheries is large, and the recovery is still very limited. For agricultural bodies, 26% of them started farming, and fish catch is still 50%. The reasons are that agricultural lands were inundated by sea water and 90% of fishery boats were lost by tsunami.

Since the recovery is different according to the areas and type of industries, they are shown in the following chapter for the three areas.

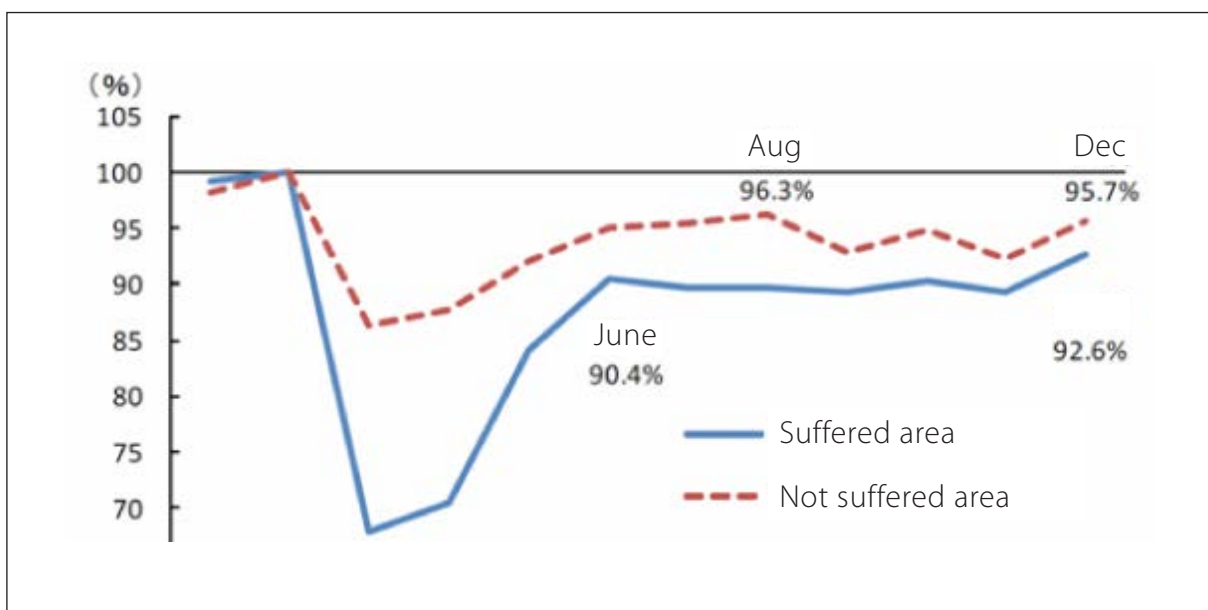

Fig. 2 Recovery of mining and manufacturing industries

### SANRIKU AREA

The major industry in this area is fishery and food processing. The situation of recovery is different even in this area. The major three towns for fishery in Sanriku area, i.e. Kesenuma, Onagawa, Onagawa, the recovery is just 30~40% due to the lost of fish boat, fish farming facilities and fish processing factories. Fishes caught are sent to harbors where the damages are small such as Shiogama. The recovery of Shiogama reached 100% until Oct. 2011. Due to the delay of land raising, rebuilding of fish processing factories are not yet started in the major three towns. It is anticipated that the fish processing moves to overseas, if the recovery is delayed.

The delay of recovery is affecting the employment. The job opening-to-application rate was lowest of 0.17 in May 2011 at Kesenuma, and gradually increasing to 0.43 in Dec. 2011, which is much lower than the value of Miyagi prefecture (Fig. 3). A serious situation is occurring for young generation. About 88% of graduates of high schools in Kesenuma have found jobs outside of the town, which will affect much the recovery of the town in near future.

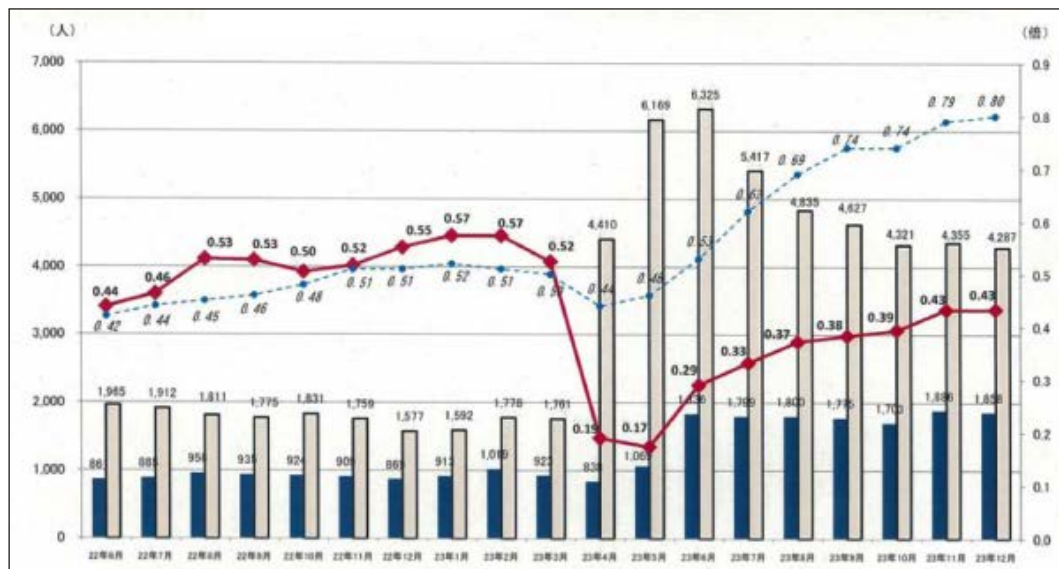

Fig. 3 Variation of job opening-to-application rate at Kesennnuma (red line)  
And Miyagi prefecture (broken blue line)

On the contrary, technicians for construction such as heavy machine operator are in shortage. This kind of jobs, however, need some qualification and license, and therefore usual people cannot find jobs in this area.

A promising way for recovery in this area may be sightseeing. Sanriku area has many resources for sightseeings. Sanriku coast is designated as one of the national parks in Japan (Rikuchu Kaigan National Park, see Fig. 4) where unique and beautiful scenery of saw-tooth type coastlines with length of 240 km exist. The sea along the coast is one of the three world-richest fishing ground, which can provide fresh and healthy sea foods to visitors. Close this area, there exists chu-sonji temple established in 850 AD which was designated as the world cultural heritage by UNESCO in the last year. Other cultural heritages such as Tohno area are well-known as treasure houses of old Japanese folklore.

Sanriku area has been continuously experienced huge tsunami, such as in 1896 (Meiji sanriku tsunami, dead and missing 21,959), 1933 (Showa sanriku tsunami, dead and missing 3,064), 1960 (Chile tsunami, dead 142). Therefore, traditional way of recovery is not allowed, and raising of lands for business zone and construction of new residential areas at safer zone are necessary. Sanriku express way which traverses along the Sanriku coast should be completed as soon as possible for this area to be connected with Sendai and Tokyo.



Beautiful scenery printed in Japanese postage stamps issued in 1955



Chu-sonji ([ja.wikipedia.org/wiki/](http://ja.wikipedia.org/wiki/))

Fig. 4 Natural and cultural heritages of Sanriku area

## SENDAI AREA

The inundated farmlands in Sendai plain are 5,548 ha, where rice, vegetables and fruits are produced. Removal of the deposited sediment and salt are necessary for recovery for agriculture. Consolidation of farmlands possessed by each farmer and introduction of new way of management, such as agricultural company, are also required. Another problem in agriculture is rapid increase of aged farmers. At present, 60% of farmers are older than 65, which makes the recovery difficult. A new way of management and introduction of high technology for agriculture to be adaptive to TPP (Tran-Pacific Partnership) are suggested. This may attract young people to the agriculture in this area and can provide jobs to people suffered from tsunami.

The recovery of Sendai area is remarkable except for agriculture. Input of huge amount of money into many recovery projects in this area has produced active economic situation in Sendai area. Industrial products such as cars and electronics are almost recovered. An important lesson from the tsunami and the flooding at Thailand is that supply-chain can be easily broken by natural disasters. The traditional just-in-time method should be modified, and the system should become more redundant. As shown in Fig. 3, the job opening-to-application rate is much higher than that before the earthquake. However, many construction projects induce remarkable shortage of civil engineers and technicians such as operator of construction machines. Existence of high way in Sendai plain was very effective to prevent the tsunami to move inside of the plain, which may be applicable to other areas where large tsunami is expected to occur in near future.



Sendai summer festival in Aug. 2011



Repair of damaged building

Fig. 5 Recovery at Sendai city

## FUKUSHIMA AREA

The most serious and difficult area damaged by the disaster is Fukushima, where lands were contaminated widely by radioactives released from Fukushima Dai-ichi nuclear power plant (Tokyo Electric Power Company, TEPCO). There is another nuclear power plant in Miyagi, Onagawa nuclear power plant (Tohoku Electric Power Company), which locates much closer to the center of the earthquake and was stopped safely without serious problem. What is the difference between Fukushima and Onagawa?

Onagawa nuclear power plant was very carefully designed for tsunami. Planners (civil engineer) studied tsunamis occurred in the past, and they noticed that there was a huge tsunami in 869 (Jyogan tsunami). It is written in a national historical record that Senadi plain became like sea and about 1,000 people were killed by the tsunami (the population of Japan at the time was 6 millions which is 1/20 of the present).

Considering these records, the elevation of the ground for the nuclear power plant was decided to be 14.8 m. The height of tsunami in this earthquake was 13.6 m at Onagawa. Besides this, another facility for tsunami was prepared. At retreat phase of tsunami, it becomes difficult to take cooling water from the sea. Therefore, they prepared a channel from which cooling water can be supplied for about 40 minutes.

On the contrary, Fukushima Dai-ichi nuclear power plant lacked carefulness and sensitivity. The designed height of tsunami was 6.1 m, and the ground elevation was 10 m. Some researchers warned the high possibility of occurrence of huge tsunami which has been to occur with an interval of about 1,000 years from the observation of depositional soil layers at Sendai plain. Since more than 1,100 years has passed from the last huge tsunami in 869, occurrence of huge tsunami can be expected and warned by several researchers. However, the top administrators of TEPCO neglected the warning, which produced tremendous damages in Fukushima, Japan as well as the world.

Fig. 6 Distribution of radioactive contamination  
(Reproduced from [www.nnistar.com/gmap/fukushima.html](http://www.nnistar.com/gmap/fukushima.html))

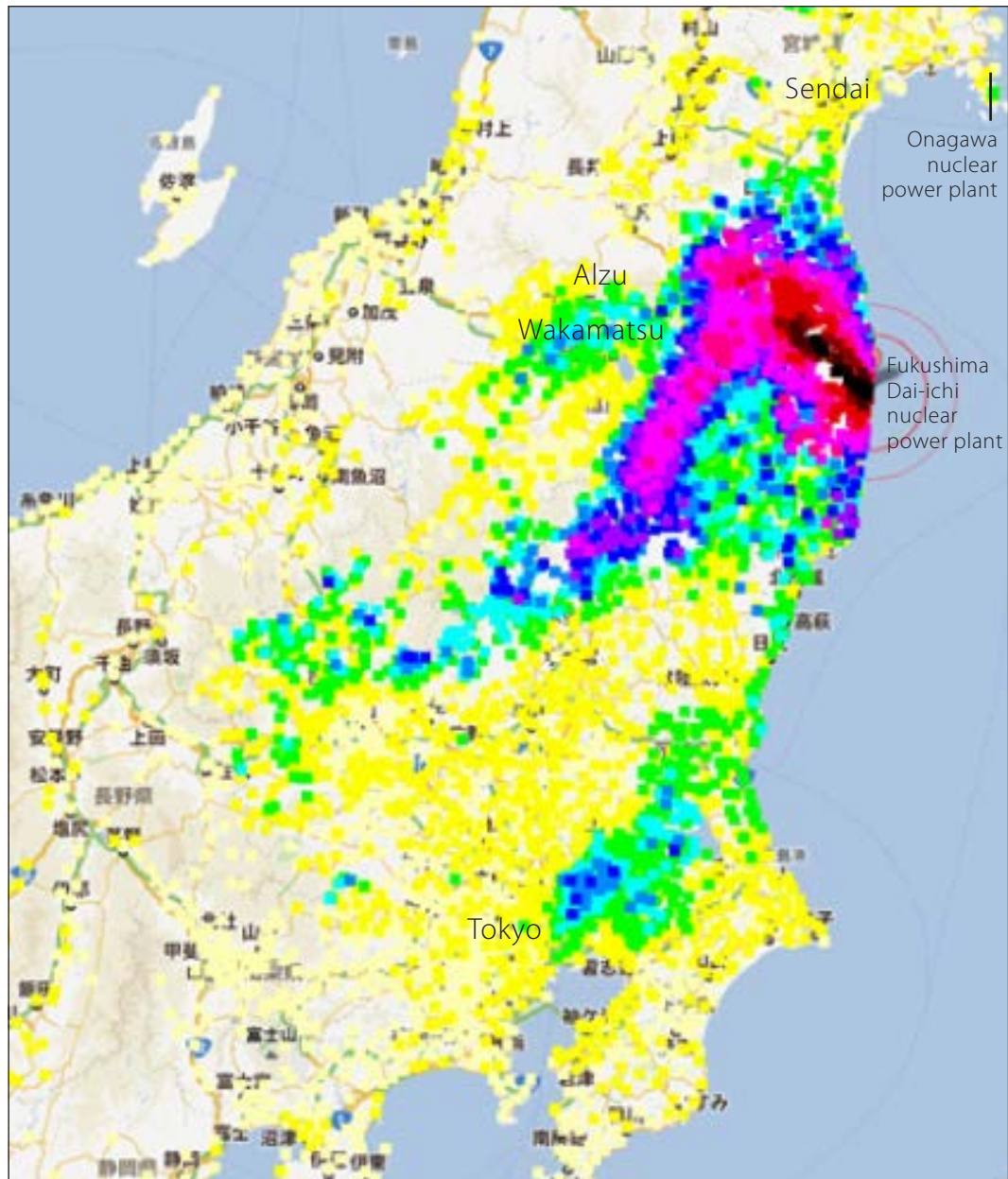



Fig. 6 shows the distribution of radioactive contamination. The number of evacuation in Fukushima is still 163,000. Removal of contaminant from the residential ground and forests are the most urgent countermeasure for people to come back to the area and to continue working. However, the places for temporal deposition of removed surface soils are difficult to find, because people usually do not agree the transportation of contaminated soils to the areas where they are living.

For agricultural products and fisheries, the government determined a new standard for the contamination. The new standard of radioactive cesium for foods such as rice, vegetables is 100 and water for child is 10 becquerel/kg. The agricultural products which exceed the value are not allowed to sell. It has been known that Shiitake mushroom and bamboo root are sometimes contaminated by radioactive cesium. These values are sufficiently low for the health. However, people are still anticipating the effects to the health, and the agricultural products harvested in Fukushima are difficult to sell. The agriculture and fisheries in Fukushima are thus severely damaged.

The sightseeing business is also much affected by the accident due to the decrease of domestic and foreign visitors. For example, Aizu-wakamatsu which is the major city known as sightseeing place has received 2.35 millions visitors in 2011 which is 15% decrease compared with the previous year, though the radioactive contamination in the city is 0.11 micro-Sievert which is smaller value than 0.13 of Edogawa ward in Tokyo. Thus, damages caused by rumor for foods and sightseeing are large. The government should make more effort to explain the safety rationally to foreign countries as well as Japanese people.

There is a project to build floating wind power generators in the sea near Fukushima. A consortium has been organized to start the project financially supported by the Ministry of Commerce and Industry, in which such as heavy industrial company, construction company, steel company, ship building company, merchandise company, university are joined. The 1<sup>st</sup> term project has started in 2011 to build a 2MW down wind type floating power generator. The 2<sup>nd</sup> term during 2013~2015 will build two 7MW class generators. It is expected that this new business will produce jobs in this area.

## SHORTAGE OF CIVIL ENGINEERS

Investigation into the amount of damage at each local government and the subsequent assessment for budget for recovery have finished until the end of 2011. In conducting the recovery projects, many professional engineers are needed. For example, Miyagi prefecture suffered the largest damages, and the budget for the recovery is about 11 billion US dollars for the fiscal year of 2012, which is 3~4 times of that of usual year. For small local municipals, they have not employed professional engineers who can perform planning and construction management. Though these situations are realized widely, the government have not take effective countermeasure for the shortage of engineers. Shortage of technicians who can operate construction machines is also serious, which has induced remarkable increase of wages. Therefore, even if a lot of money is prepared, it is difficult to conduct the recovery projects. A possible way for solution is to employ temporally skilled experts who worked in consulting and construction companies and retired recently.

## REBUILDING OF HOUSES

The way of rebuilding of business buildings and residential houses should be changed. Almost all concrete buildings and pillar-type buildings could resist the force of tsunami and remained, which indicates that pillar-type buildings are recommended for reconstruction of buildings. Fig. 7 shows a pillar type building which is still used after the tsunami, though nearby-other houses were completely broken.



Fig. 7 Buildings remained at Kesenuma

## ACKNOWLEDGMENT

Support of Miyagi prefecture, Kesenuma city and Science Council of Japan at field observation is very much appreciated.



**Dr. Keiko Tamura<sup>(1)</sup>,  
Takashi Furuya<sup>(2)</sup>, Haruo Hayashi<sup>(3)</sup>,  
Japan**

**Web-Based Victims Master Database System  
for Effective Support in Victims' Life  
Reconstruction Process-A Study of 2011  
Earthquake off the Pacific Coast of Tohoku**

<sup>(1)</sup> Risk Management Office, Niigata University, Japan

<sup>(2)</sup> Research Institute of Science and Technology for Society,  
Japan Science and Technology Agency, Japan

<sup>(3)</sup> Disaster Prevention Research Institute, Kyoto University,  
Japan

E-mail: [tamura@gs.niigata-u.ac.jp](mailto:tamura@gs.niigata-u.ac.jp)

**ABSTRACT**

Supporting the victims' life reconstruction process after the disaster is the huge task to realize because the responders must handle an immense amount of victims' information in a chaotic situation. On top of that, its business flow had not established and standardized well and there was no effective tool to support the business. We developed the Victims Master Database (VMDB) System as the best solution. We deployed the VMDB system into 7 cities and towns in the impacted area of Iwate Prefecture by 2011 Earthquake off the Pacific coast of Tohoku. This paper introduced the actual state of victims' life reconstruction and the process of solving a variety of challenges faces in the reality of the disaster areas.

Also, this paper is reported as one of the preceding examples of the R&D program "Creating Community-based Robust and Resilient Society" [1] which is relevant to safety and security by JST-RISTEX in Japan.

## 1 INTRODUCTION

In the event of a disaster in Japan, local governments provide many types of administrative services to victims. Before the provision of these services, victims have to be identified and apply to the support programs. Victims are identified on the basis of building inspections for the assessment of building damages. The results of the building inspection are compiled in a database and certification of the degree of building damages are in turn granted to the victims.

Previously, a basic database was constructed to manage the certifications for the degree of building damages. However, this database did not contain geo-reference information. Therefore, this database has limited utility for providing basic information for providing subsequent support services to victims.

## 2 WORK FLOW OF ADMINISTRATIVE SUPPORT

In order to circumvent these issues, in this research we decided to develop a database to house the results of building inspections with geo-reference, and to grant certification of the degree of building damage based on this geo-database. Furthermore, we proposed to develop the VMDB to store a variety of victim information that can be used in concert with the geo-database of building damage certification to facilitate effective and prompt support services to victims. Local responders can also use the VMDB to provide a plethora of administrative support to victims. The proposed effective work flow is shown in Figure 1.

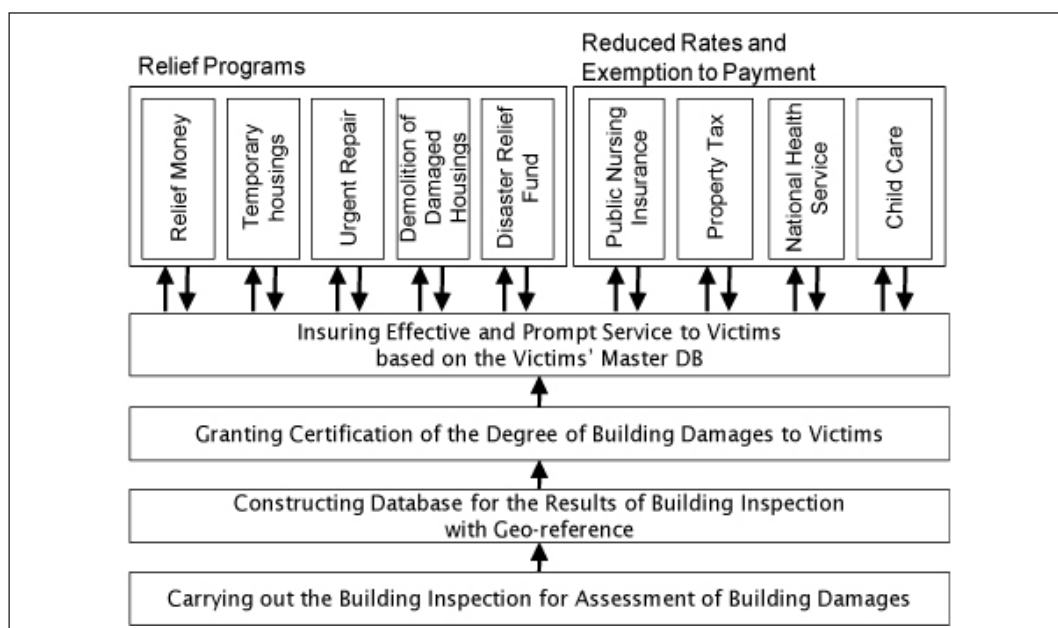

Figure 1. Work Flow of Administrative Support

## 3 METHODOLOGY OF DEVELOPING A VICTIMS MASTER DATABASE

Requirements for issuing a Disaster Victim Certificate on the basis of a victim's application are: To identify an individual or a household on the Basic Resident Register (Jumin kihon daichou), to identify which house is their primary residence where their life is centered, and to find out the results of a building damage certification survey. To gather these required pieces of information, it is necessary to extract and collate the applicable data from the (1) Basic Resident Register, (2) Property Taxation Database, and (3) Building Damage Certification Survey. Items (1) and (2) are databases for a normal time, and item (3) is a database built after a disaster occurs. There are a plethora of issues listed below that affect the ability to connect items (1), (2), and (3) together.

### 3.1 Basic Resident Register and Property Taxation Database do not share a common primary key

The primary key of the Basic Resident Register is an individual number or a household number to designate a resident. On the other hand, the primary key of the Property Taxation Database is a house number used to set tax on a building. The Property Taxation Database may also contain an individual number in some municipalities if the tax payer is a resident of that jurisdiction. However, this is not standard procedure. Therefore, these two databases cannot immediately be combined.

### 3.2 The only primary key of Building Damage Certification Survey is location

The Building Damage Certification Survey is organized according to locations used to conduct a survey at disaster afflicted areas. Therefore, information on the residents and houses is not known, and as such, Basic Resident Register and Property Taxation Database and Building Damage Certification Survey cannot immediately be combined.

### 3.3 Proposition of Novel Technology to Combine Databases with Different Primary Keys

Our research and development team developed a GeoWrap Method that connects data from different databases using spatial location relationships instead of primary keys. The GeoWrap Method employs the Geographic Information System (GIS) to position information from each database in a space, and the spatial distance between pieces of information is designated affinity. This affinity assigns weight between the pieces of information and provides rank order among the pieces of information. Therefore, the information from each database is converted into spatial information. The spatial information was then taken into the GIS to calculate affinity based on spatial distances among the pieces of information. This was an automated process for generating flexibly connected pieces of information (See Figure 2).

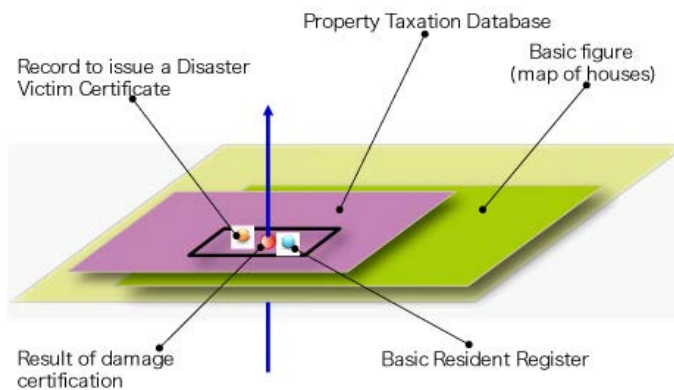

Figure 2. Work Flow of Administrative Support

### 3.4 The Purpose of Issuing the Building Damage Certification

When a resident applies for a Disaster Victim Certificate, a simple search of the “resulting data that are flexibly connected together in a space” makes a resident identify their primary residence based on the information provided. By presenting a Building Damage Certification Survey result, we can let the resident complete the entry of the Victims Database. A major feature of this system is that it effectively combines automation as an optimum solution and a real solution provided by humans.

## 4 PROPOSAL OF THE SYSTEM APPLICATION TO BUILD VICTIMS MASTER DATABASE

### 4.1 Installing a graphical interface using a map

Visualization of rank ordered information in each database on a map would facilitate an applicant identifying their primary residence based on his or her actual place of residence.

## 4.2 Installing a graphical interface using a map

List information would be color-coded for each database and displayed on a map. Rank order information would be made into a list for each database and displayed at the bottom of a map. An applicant would compare the map and the list to make the following selections (Figure 3):

- (Basic Resident Register) the displayed address information for the applicant match the actual information
- (Property Taxation Property) property taxation information displayed as the primary residence match the actual information
- (Tremor Survey Research Results) in the applicant's opinion, the displayed results of the building damage certification survey accurately reflect the damage due to the earthquake
- (Fire Damage Survey Results) in the applicant's opinion, the displayed results of the building damage certification survey reflect the damage due to a fire

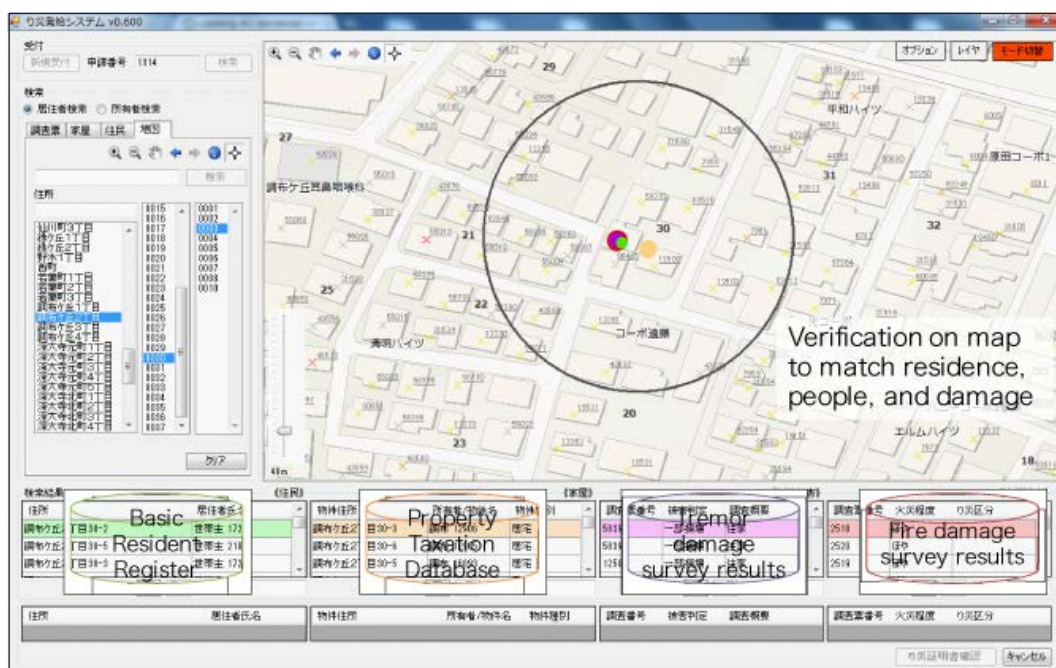

Figure 3. System to Apply and Issue Disaster Victim Certificate  
(Interactive information search system between an applicant and a municipality clerk)

## 4.3 Development Environment

This system was implemented in an environment to coordinate DBMS (Database Management System) and GIS. For the DBMS, an SQL server was used as a server-client database system. The SQL server can be substituted with MS-Access (MDB) if only a client alone is used. A GIS server or GIS server runtime can be selected for the GIS function.

## 5 APPLY THE SYSTEM OF BUILDING A VICTIMS MASTER DATABASE TO THE IMPACTED AREA OF TOHOKU EARTHQUAKE

### 5.1 The devastating Disaster in Tohoku Area in Japan

The Tohoku Earthquake was a magnitude 9.0 (Mw) undersea mega thrust earthquake off the east coast of Japan that occurred at 14:46 JST on Friday, March 11th, 2011. This strong earthquake caused huge and destructive tsunami waves that reached heights of up to 40.5 meters (133 feet) in Miyako in the Iwate Prefecture and travelled up to 10 km (6 miles) inland in the city of Sendai. Approximately 15,200 people lost their lives and over 8,600 people were reported missing. The number of houses that were partially or totally

destroyed in the disaster was about 160,000. The tsunami caused a number of nuclear accidents, primarily the on going level 7 meltdowns at three reactors in the Fukushima I Nuclear Power Plant complex. The resulting evacuation zones affected hundreds of thousands of residents that resided in the afflicted areas including 10 prefectures and 241 cities, wards, "" districts, and villages. Because of experience from past disasters, Japan has a variety of well-organized support services to help the victims to rebuild their lives. However, standardization of the workflow in order to effectively offer these support services and build support tools are not sufficient. The amount of work required is extremely large since the areas of disaster are widespread and a large number of people need to receive support services. Therefore, it necessitates the establishment of a workflow and support tools. Herein, we describe the generation of a Victims Master Database in order to effectively provide support for victims.

## 5.2 The Research Field of Iwate Prefecture, one of the most impacted area

In Iwate Prefecture, 12 cities and villages along the coast suffered damages, and many victims are currently trying to rebuild their live. As a shared infrastructure for all these cities and villages, we installed a server within the Iwate prefectural office to implement the VMDB system. This server was installed on a LGWAN (also called Iwate Information Highway) that connects cities, and villages in Iwate Prefecture. This enabled network access from information terminals at each municipality in a closed environment with a high level of security, and safe and stable system operation.

After the Tohoku Earthquake occurred, many administrative functions were damaged and some of them were actually broke down. During that time administrative officers started to provide service of life reconstruction support for the victims in their temporary offices. As a result their work styles and workflows lacked coherence and nobody can detect how much support service had already provided for victims or had not provided yet. 7 cities and villages out of 12 now use the service of Web-Based Victims Master Database System for supporting the process of life reconstruction for re-organizing their works. 7 cities and villages aimed for realizing the situation being nobody who had not much support would be left (Figure 4).

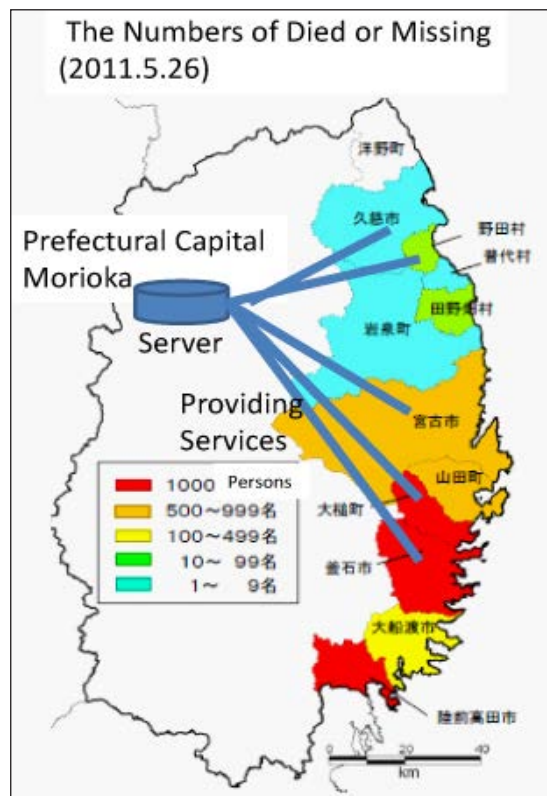

Figure 4. Services of Web-Based Victims Master Database System for supporting the process of life reconstruction

## 6 CONCLUSIONS

Although the system developed through this research is based on experiences from past disasters, knowledge about wide-area, a complex disaster such as the Great East Japan Earthquake is not adequately incorporated. We are planning to make revisions to the system in order to combat the challenges that will surface as this system is continually used. Earthquakes are expected to occur in Tokai, Tonankai, and Nankai regions around Japan in the middle of the 21st century. We would like to further improve this system to aid in the early recoveries from these potential future earthquakes.

## ADDITIONAL NOTES

[1] The Research Institute of Science and Technology for Society (RISTEX) as one of the institutions of the Japan Science and Technology Agency (JST), supports a wide range of R&D projects and aims to yield outcomes to solve the serious problems that we and our society in the 21st century now face. The activities of RISTEX are unique and unlike other R&D projects in every respect, ranging from producing new R&D focus areas to promoting area management and support for returning the results of R&D Program to society. In FY2012 the R&D focus area: "Creating Community-based Robust and Resilient Society" was newly established.

## BIOGRAPHY

Keiko TAMURA, Ph.D.

Professor, Risk Management Office, Niigata University, Japan

2004-2006 Researcher, Research Center for Disaster Reduction Systems, Disaster Prevention Research Institute, Kyoto University, Japan

2006-2009 Associate Professor, Research Institute for Natural Hazards and Disaster Recovery, Niigata University, Japan

2009- Professor, Risk Management Office, Niigata University, Japan

Takashi FURUYA, Ph.D.

Associate Fellow, Research Institute of Science and Technology for Society, Japan Science and Technology Agency, Japan

Haruo HAYASHI, Ph.D.

Professor, Disaster Prevention Research Institute, Kyoto University, Japan



# Ashok Basa, India



313

ASHOK BASA

## The 2004 Indian Ocean Tsunami – Impact on India

The Institution of Engineers – Civil Engineering Division  
Board, B. Engineeres & Builders Ltd., Bhubaneswar

E-mail: [b\\_eb@hotmail.com](mailto:b_eb@hotmail.com)

### ABSTRACT

Tsunami, a Japanese word, means “harbour wave”. The seismic activities deform the seabed causing vertical rise of the overlaying water of the seabed resulting creation of large waves known as tsunami. The 2004 Indian Ocean Tsunami was caused by an earthquake near Sumatra of magnitude 9.1 – 9.3, the third largest recorded earthquake of the world and having a duration of faulting of 8.3 to 10 minutes, the longest ever observed. It is considered as one of the deadliest natural disasters causing a death toll of 2,30,000 people in 14 countries including India. The paper will contain India’s heavy loss alongwith high human casualties, how India faced it through relief, restoration & rehabilitation and her steps for future preparedness based on lessons learnt.

## 1. INTRODUCTION

Tsunami (soo-NAH-mee) a Japanese word, means “harbour wave”. The seismic activities involving tectonic subductions deform the seabed causing vertical rise of the overlaying water of the seabed resulting creation of large waves known as Tsunami. In deep ocean Tsunami has low height. When it reaches near the shore with shallow depth, the kinetic energy is converted in to potential energy causing very high waves. Therefore Tsunami waves are very high near the shore. The 2004 Indian Ocean Tsunami (2004 IOT) which occurred on 26th Dec’2004 is one of the **deadliest natural disasters** involving a death toll of about 2,30,000 people in 14 countries including India. This is one of the **worst earthquakes** in recorded history as well as the **single worst Tsunami** in the annals of disaster. “The 26th Dec’2004 Tsunami is also known as South Asian Tsunami, Boxingday Tsunami, Indonesian Tsunami besides 2004 Indian Ocean Tsunami. Not all earthquakes cause Tsunami. There will be no Tsunami by the earthquakes which cause movement of seafloor in horizontal direction. Only when the earthquake will cause vertical movement of the sea bed, then only Tsunami will be created. Earthquake having magnitude of more than 6.5 & leading to vertical movement of the seabed can cause Tsunami. In the history of coastal districts of India, 2004 IOT have probably created the worst impact on India.”

## 2. CAUSES OF TSUNAMI – 2004

The 2004 IOT which occurred on 26th Dec’2004, was caused by a huge earthquake of magnitude of 9.3 having the longest duration of faulting ever recorded between 8.3 to 10 minutes. “The earthquake occurred along a tectonic subductions zone in which the Indian plate is subducted beneath the Burma micro plate. A large fault was resulted in the interface between the two plates. When one plate is forced to dive beneath another plate, there is no way to do it except with some component of vertical motion creating Tsunami. The sea floor on the overriding Burma plate deformed vertically, uplifting sea ward toward the trench and down dropping (subsiding) landward toward the coastline”. An interesting phenomena occurred during this Tsunami. “People saw sea water disappearing away from the beaches in the minutes before the giant wave lashed back with infernal fury devouring whatever came on the way of their lethal onslaught.”



Fig.1 COASTLINES SEVERELY HIT BY INDIAN OCEAN TSUNAMI – 2004

- \* Chairman, Civil Engineering Division Board, The Institution of Engineers (India).
- \* Member, Disaster Risk Management (DRM) Committee, World Federation of Engineering Organisation (WFEO).
- \* Director (Technical), B. Engineers & Builders Ltd., 72/A, Mancheswar Industrial Estate, Bhubaneswar-751010 (India).

Depth of water plays an important parameter for Tsunami velocity. The higher the depth of water, higher is the velocity.  $v = \sqrt{gh}$ . For example inside the sea, Tsunami travel at a velocity of 700 kmph in 4 km depth of sea water, where as in 10m depth of water it gets reduced to as low as 36 kmph. The Tsunami from Sumatra coastal earthquake traveled to Tamilnadu in about two hours. It is interesting to note that in deep water (greater than 200m) Tsunamis are rarely over one metre high where as in shallow depth, the wave height increases drastically to about 10 times. In case of 2004 IOT, it propagated out-bound across Bay of Bengal towards India & Srilanka eventually reached the Atlantic and Pacific Ocean.

### 3. TSUNAMIS IN INDIA

Recording of Tsunami in India was not very exhaustive. There has been occurrence of two Tsunamis in 20th Century and one in the beginning of 21st Century. On 26th June 1941, there was a quake in Andaman sea of magnitude 8.1 which caused Tsunamis in the east coast of India with amplitude from 0.75 to 1.25m. The Makran earthquake (27th Nov'1945) of magnitude 8.1 led to formation of 12 to 15m wave height in Makran coast with considerable damage. In Gulf of Cambay of Gujarat estimated height was to the tune of 11m. During that time the estimated wave height in Mumbai coast was about 2m. Boats were taken away and causality occurred. The most recent Tsunami caused by the 26th Dec'2004 earthquake of magnitude 9.3 off Sumatra coast, which had devastating effects in India.

Thus in case of Indian region, the potential sources for creation of Tsunamis in western coast is the Makran region and the eastern coast is effected by earthquake in Andaman to Sumatra region.

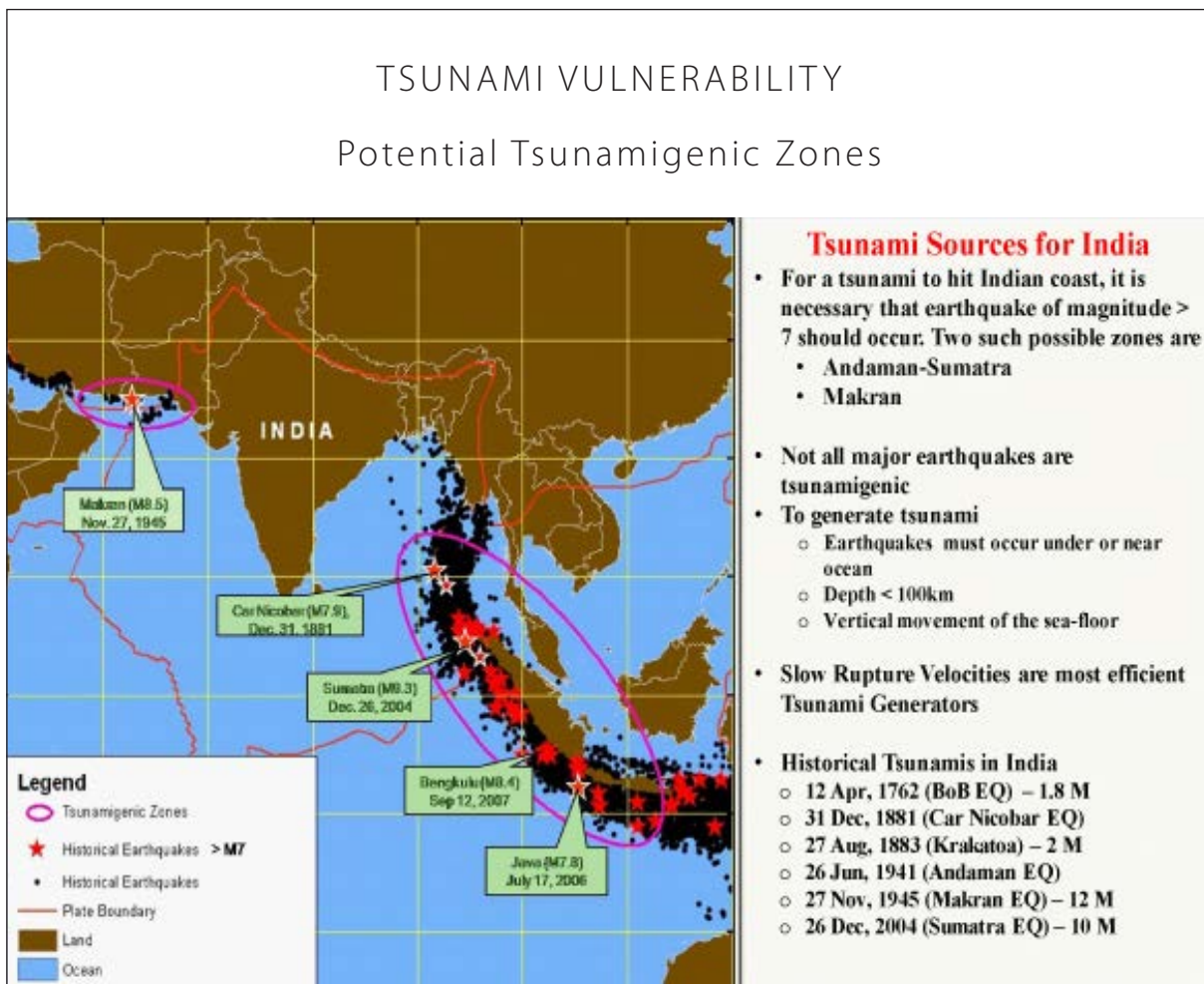

Fig.2

#### 4. DAMAGES OCCURRED DURING 2004 TSUNAMI.

The 2004 Tsunami is the deadliest in the recorded history having a death toll of about 2,30,000 in 14 countries.

Indian main land was hit by the Tsunami two hours after the earthquake. About 11,000 people died, 5000 missing and feared dead. 3,80,000 Indians were displaced by the disaster. The worst effected state was Tamilnadu having total death toll about 8000, out of which Nagapattinam district alone had 5500. In Chennai, the capital city of Tamilnadu, people playing in the marine beach and the people doing their morning walk were washed away. The worst effected were the fishermen who lost everything in term of life and property.

Andaman and Nicobar islands were also effected badly because of the proximity to the epicenter of the earthquake of magnitude 9.3. It is reported that Tsunami reached at height of about 15m in the Southern Nicobar islands. Though the official death toll was less than 900, 7000 were feared missing. About 572 islands constitute Andaman & Nicobar. Because of flat terrain and proximity to the epicenter of the earthquake, Nicobar island lost about 1/5th of her population. Some islands have been totally washed away and some splited into two parts. Indian Air force had a very important base station in Car Nicobar island where more than 100 Indian Air force personnel along with their family members were washed away.

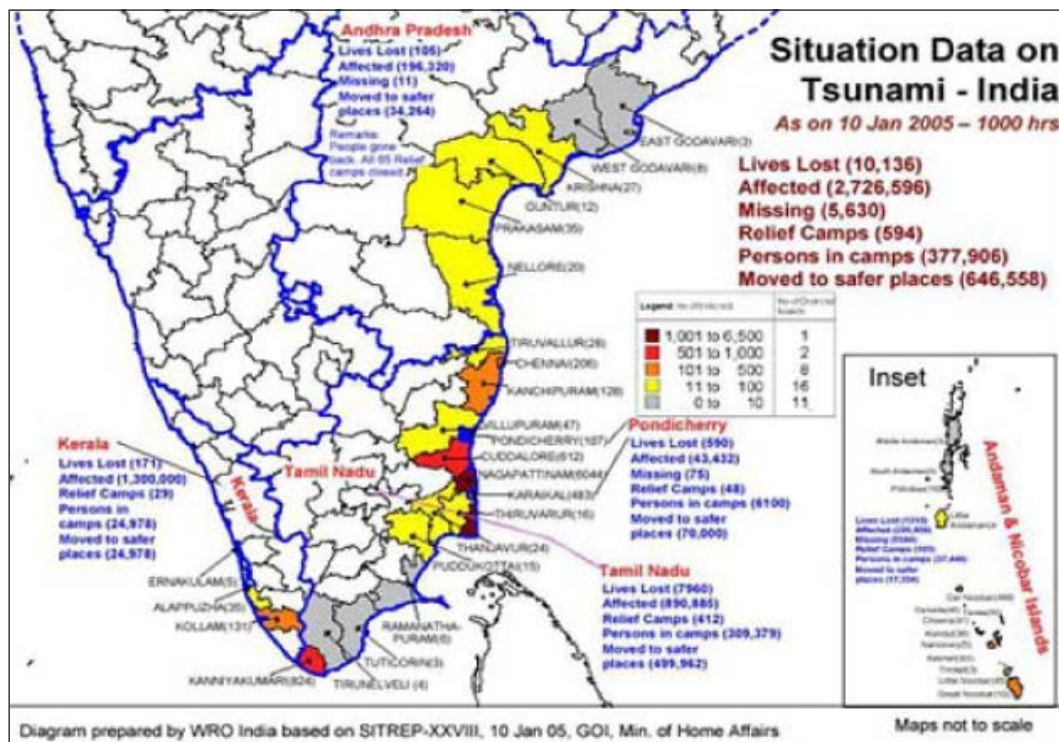

Fig.3 Areas most affected by Tsunami

Besides people from Indian main land like Tamilnadu & West Bengal, Andaman & Nicobar have their own native population. Regarded as anthropologically significant the endangered tribal groups consisting of JARAWA, ONGE, ANDAMANESE, SENTINELESE are some of the world's most primitive tribes and considered as world's only link to the ancient civilization. The Govt. of India has decided not to interfere with them as they have maintained their aboriginal life style for centuries. **It is quite interesting to note that these primitive tribes who are the native islanders could remain safe as they live faraway from the coast at higher ground level.** They had a tradition that once the earth shakes, they would move into hilltop or higher ground.

Besides some of the states like Pondichery, Kerala and Andhra Pradesh were also effected.

It was known that about eighty percent of the effected people were from the fishing communities. More than 50,000 fishing vessels were damaged. In Tamilnadu several fishing villages were completely destroyed. In some cases the whole population of some areas were wiped out.

Thus 2004 IOT has caused severe damage to India, which ranked third after Indonesia and Sri Lanka as far as losses are concerned.

## 5. REHABILITATION MEASURES

Relief camps were opened with adequate food materials in the effected areas. Ex-gratia to next of kin of all dead/missing persons and orphans were given at the earliest. Intermediate shelters were provided for quite a long period along with food. Child help line service, Trauma counseling services set up. Enhanced compensation package for crop loss was also provided. Financial help given for repair of damaged boats, in some cases for new boats. Drinking water to all affected areas was restored at the earliest. Rain water harvesting structures were provided in the intermediate shelters. Timely preventive measures were taken to ensure any outbreak of communicable disease. Schools were immediately re-established in temporary structure. The total re-construction was expected to cost 1.2 billion dollars (US).

## 6. IMPACT

**6.1 Economic Impact** - Although the overall impact on the national economic was minor, the Tsunami caused devastation of the local economy. The boats of the fishermen were terribly damaged, in some cases beyond repair. The coastal belt was full of poor fishermen. They did not have bank account. As such their savings used to be kept in their homes, which were completely swept away. So after the Tsunami they did not have anything with them. To add to their misery just after the Tsunami the prices of fish dropped drastically. It was thought by people that the fish might be contaminated with disease as they might have fed dead bodies in water. The fears were unrealistic, but the demand for fish got drastically reduced causing very low price of the fish. Moreover the fishermen also use fish as their diet. In some cases the fishermen after repairing their boats with much difficulty found that prime fishing spots were unproductive due to changes in the ocean floor. Sand brought in from Tsunami effected the availability of fish. Thus the Tsunami really shattered the local economy of the people living near the coast.

**6.2 Environmental Impact** – The 2004 IOT had massive long term environmental impact on ecosystems such as coastal wetlands, vegetations, sand dunes, mangroves, forests, plant & animal biodiversity and groundwater. Water pollutions threatened the environment further. The United Nations Environment Programme (UNEP) is working with the environment to determine the severity of the ecological impact and how to address it.

**6.3 Social Impact** – There was increased number of cases involving psychological trauma caused by Tsunami. The death of the near and dear ones caused disturbed mind. Moreover the possibility of spread of disease caused further problems involving good health and hygienic state. The main concern was to provide sanitation facilities and fresh drinking water to check the spread of the disease such as dysentery, cholera, typhoid etc. Most important efforts was made to bury bodies at the earliest to check the spread of the disease.

**6.4 Other effects** – There have been notable physical changes occurred along the Indian coastline after the Tsunami. Comparison of pre and post Tsunami vectors from mainland to Andaman & Nicobar islands clearly show that the islands have moved 2 to 3 metres in horizontal position towards the mainland and

also the islands have rotated in anti clock wise direction. Vertical subsidence of approximately 0.8m was observed at Portblair with respect to Dehradun permanent station. From the tidal analysis, it was found that there is a rise in local mean sea level of an order of 1.05m at Chatham observatory, Portblair.

## 7. DEVELOPMENT OF EARLY WARNING SYSTEM FOR TSUNAMI

Unlike in Pacific Ocean, no Tsunami warning system existed in Indian Ocean prior to the 2004 Tsunami. Therefore, when it came on 26th Dec'2004, it was a complete surprise for the nations surrounding the Indian Ocean, as they had to face exceptional devastation amounting to national calamities. The loss of lives in 2004 IOT has suppressed by many orders with reference to the Tsunamis occurred over the last three decades in the Pacific. Therefore as a part of future mitigation and management plan, it was felt by the Government of India (GOI) that development of **Indian Tsunami Early Warning System (ITEWS)** be completed on topmost priority.

Tsunami Early Warning System is based on the concept that Tsunamis travel at much slower velocity (500 to 700 km per hour) as compared to seismic waves (21,600 kmph to 28,800 kmph or 6 to 8 km per sec). That is seismic waves move about 40 times faster than Tsunami waves. Thus after the occurrence of a damaging earthquake and quick determination of epicenter, warning time of a few minutes to 2 – 3 hours is available depending on the distance from the epicenter to the coast line. This time can be utilized for warning the coastal community if quick detection and rapid communication systems are established.

In order to have early warning system for Tsunami, Bottom Pressure Recording (BPR) System for Tsunami detection and its Moored surface Buoy system floating on selected locations of sea water for real time communication have been developed.

"The Bottom Pressure Recording (BPR) detects greater water pressure when a passing tsunami increases the height of water above it. The surface buoy receives transmitted information from the BPR via an acoustic link and then transmits data through a satellite link to central stations.

### Importance of BPR

From historical studies, it is clear that all earthquakes in tsunamigenic source regions can not trigger tsunamis. In order to confirm whether the earthquake has actually triggered a Tsunami or not, it is essential to measure the change in water level in the open ocean with high accuracy in real time. Bottom pressure recorders are used to detect the sea level changes near to tsunamigenic source regions and consequent propagation of Tsunami waves in the Open Ocean.

### BPR Network setup

As part of the Indian Tsunami Early Warning System, a real time network of Deep Ocean Assessment and Reporting System has been established by National Institute of Ocean Technology (NIOT). The network is designed to detect, measure and monitor tsunamis. The network comprises of 12 BPRs transmitting real time data through satellite communication to NIOT at Chennai and INCOIS at Hyderabad simultaneously for processing and interpretation. Each BPR is strategically placed at 30 minute and 60 minute tsunami wave arrival times (from hypothetical tsunami sources), so that they offer sufficient warning time and redundancy. At the same time, they are far enough from the earthquake zone so that the tsunami wave signal can be clearly distinguished from the seismic Rayleigh wave. In addition to Indian BPR network, INCOIS is also receiving real time data from internationally coordinated networks like DART (Deep Ocean Assessment and Reporting Tsunamis) in Indian Ocean via Internet. Currently, NIOT has deployed four BPRs out in Bay of Bengal and two BPRs in the Arabian Sea.

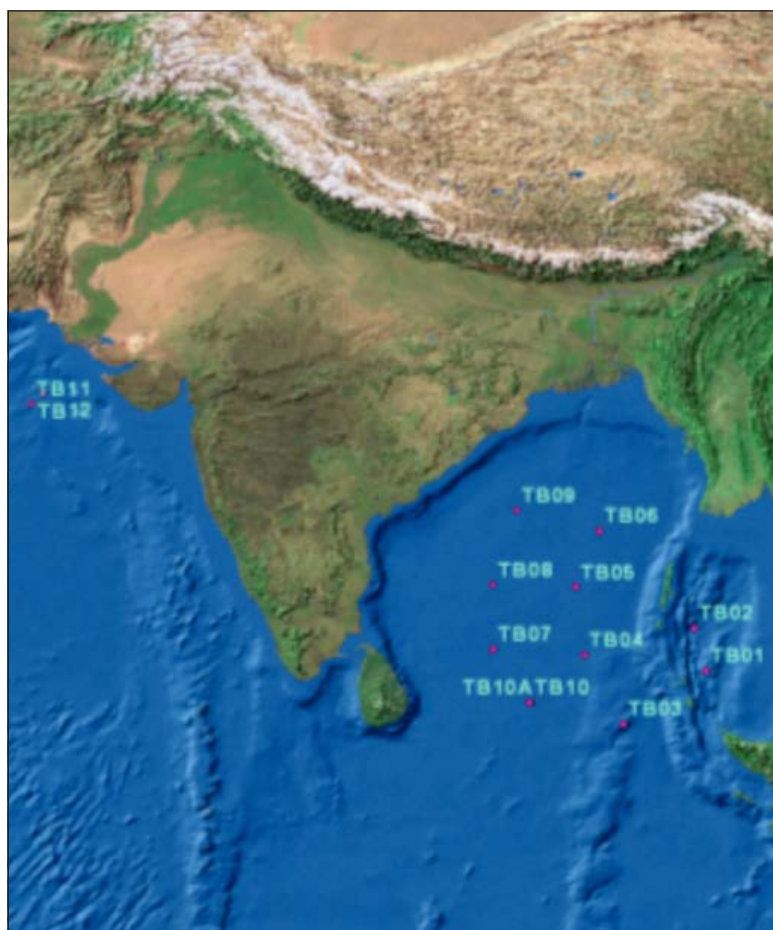

Fig.4

### BPR Configuration

Each BPR system consists of an anchored sea floor Bottom Pressure Recorder with acoustic link to a companion Moored Surface Buoy (Fig.5 & Fig.6) for real time communications and is designed to detect and report tsunamis if the pressure fluctuations are above a preset threshold. The BPR operates in one of two data reporting modes: a low power, scheduled transmission mode – Normal mode, samples for every 15 min and transmits for every 1 hour and a triggered event mode called as Tsunami Response Mode, samples for every 15 seconds and transmits for every 5 minutes. The BPR uses a piezoelectric Pressure transducer to make 15 seconds-averaged measurements of the pressure exerted on it by the overlying water column. The Tsunami detection algorithm running in the BPR generates predicted water height values within the tsunami frequency band and compares all new observed samples with these predicted values. If two 15-second water level values exceed the predicted values greater than the threshold (30 mm), the system will go into the 'Tsunami Response Mode'. An acoustic link transmits data from the BPR on the sea floor to the surface buoy. The data are then relayed via a satellite (e.g. INSAT) communication finally to the Tsunami Warning Centre. Each BPR system has two-way communication link and thus able to send and receive data from Tsunami Warning Centre. The data centre at INCOIS is equipped with state-of-the-art computing hardware for data reception, INSAT two-way communication hub, data processing & visualization and dissemination facilities. The BPR can be accessed from warning centre remotely at any point of time and perform the functions like trigger the BPR into tsunami response mode, inspecting the state of health, requesting the tsunami response mode data from BPR etc.

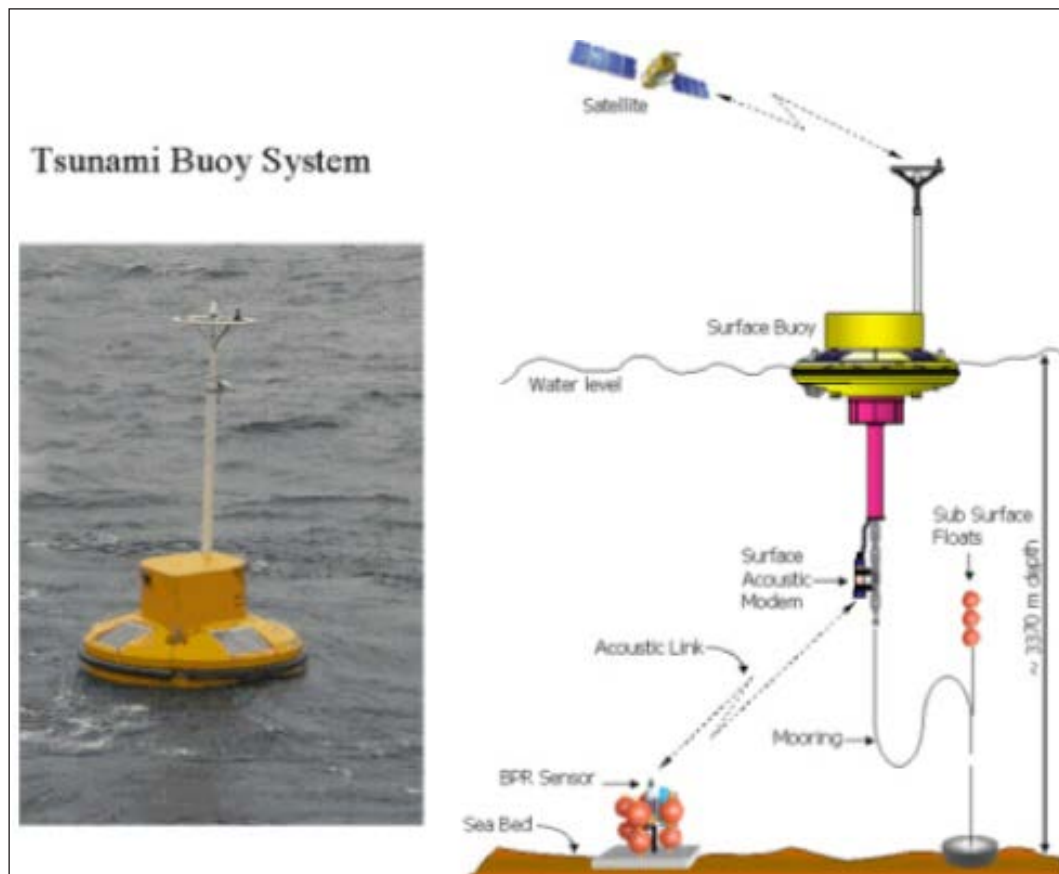

Fig.5

### Data Processing

The real time data received at INCOIS is processed by the open ocean tide prediction software for the residual data by removing the predicted data from real time observed data with some datum correction. The computed residual data is continuously monitored for significant water level changes above 30 mm."



Fig.6 Tsunami Buoys



As regards performance of ITEWS, the article on "Performance of the Tsunami Forecast System for the Indian Ocean" written by T.Srinivas Kumar et al in current science Vol.102, No.1, 10 Jan 2012 worth mentioning for information of all concerned.

"The function of ITEWS include detection, location and determination of the magnitude of potentially tsunamigenic earthquakes occurring in the Indian Ocean, estimation of travel time and run-up heights of tsunamigenic waves and dissemination of the notification to all concerned. A database of all possible earthquake scenarios for the Indian Ocean is used to identify the regions under risk at the time of the event. Significant changes in sea level are monitored at the time of occurrence of tsunami genic earthquakes. Timely tsunami bulletins (categorizing coastal areas under Warning/Alert/Watch/Threat Passed) are disseminated to the vulnerable community following a standard operating procedure (SOP) by means of various available communication methods. The ITEWS is operational since October 2007 and has been issuing accurate tsunami advisories for all under-sea earthquakes of magnitude  $M \geq 6.5$ . The warning centre is capable of issuing tsunami bulletins in less than 10 min after any major earthquake in the Indian Ocean. The ITEWS comprises a real-time network of seismic stations, bottom pressure recorders (BPRs), tide gauges and 24 × 7 operational tsunami warning centre to detect tsunamigenic earthquakes, monitor tsunamis and provide timely advisories to the vulnerable community using the latest communication methods with back-end support of a pre-run model scenario database and decision support system (DSS). The important components of the ITEWS are given below.

(1) Seismic and sea-level observation system: About 300 global seismic data are received in real-time from IRIS Global Seismographic Network and GEOFON Extended Virtual Network, including data from 17 broadband seismic stations in India established by India Meteorological Department. The seismic parameters (origin time, location, depth and magnitude) are being processed through autolocation software, namely Seiscomp and Response Hydra. The sea-level observation is monitored through two types of sea-level gauges: BPRs and coastal tide gauges. BPRs are used to detect the propagation of tsunami waves in the open ocean. A network of tide gauges helps to monitor the progress of tsunami and validate the tsunami model. The ITEWS is monitoring sea level using 25 tide gauges along the coast and four BPRs in the Indian Ocean.

(2) Tsunami modelling: The TUNAMI-N2 (Tohoku University's Numerical Analysis Model for Investigation of Near-field Tsunamis, version-2) model, customized for the Indian Ocean, is used for estimating possible tsunami travel times and run-up heights for different earthquakes. This model uses available earthquake parameters and assumes worst slip. The tsunami centre maintains a large database of pre-run scenarios for timely dissemination of the advisories. The surge heights and travel times at nearly 1800 coastal points along the Indian Ocean can be picked up easily from the database for early warning purpose.

(3) Decision support system (DSS): An exclusive DSS has been built to pickup the closest scenario from the database that helps in generating the tsunami advisories at the time of an event. That is, the DSS picks up the nearest earthquake scenario and the associated Tsunami N2 model estimates of possible water levels and arrival times along the Indian Ocean. This enables the centre to assess the possibility of tsunami generation, and the likely severity due to the rise in water level at various locations along the coasts of the Indian Ocean, and the generation of appropriate advisories for use by the disaster management authorities.

**Table 1.** Summary of the performance levels achieved by the Indian National Centre for Ocean Information Services as criteria given by International Oceanographic Commission (IOC)

Parameter	Targets	Achievements
Elapse time from earthquake origin time to initial earthquake information issuance (local/distant)	10/15 min	6 min
Probability of detection of Indian Ocean earthquakes with $M_w \geq 6.5$	100%	100%
Accuracy of hypocentre location (with respect to USGS)	Within 30 km	9.5 km
Accuracy of hypocentre depth (with respect to USGS)	Within 25 km	22.5 km
Accuracy of earthquake $M_w$ magnitude (with respect to USGS)	0.2	0.2
Reliability of RTWP operations (power, computer, communication)	99.5%	Achieved

The services of the warning centre for an earthquake event commence whenever earthquakes with magnitude  $\geq 6.5$  within the Indian Ocean and magnitude  $\geq 8.0$  outside Indian Ocean are recorded by the seismic network. Analysis of the events includes automatic and interactive processes for determining the epicentre, depth, origin time, and magnitude of an earthquake. The tsunami warning centre issues two types of products (bulletins), namely Public and Exchange tsunami bulletins. The Public products contain earthquake information (origin time, location, magnitude and depth) and tsunami-genesis potential of the earthquake. The Exchange products contain coastal forecast zones (CFZs) tagged with results of a forecast model such as estimated wave amplitude, estimated time of arrival and threat level. The CFZs are high resolution spatial boxes of  $100 \text{ km} \times 50 \text{ km}$ , extrapolated to district-level information. As the Exchange products need an expert interpretation, they are provided only to authenticated agencies through secured means.

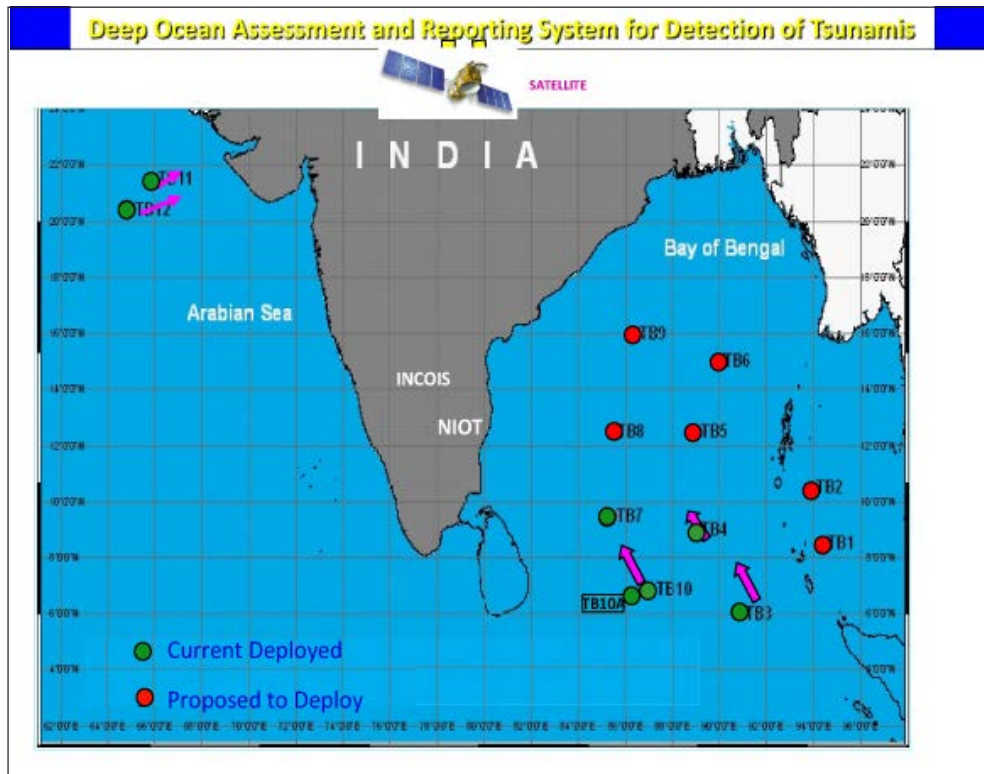

Fig.7

Since May 2010, the tsunami warning centre monitored and reported 73 earthquakes of magnitude  $\geq 6.5$  covering the entire globe. A summary of the performance of the warning centre against key performance indicators (set up by IOC-ICG/IOTWS-V/13)<sup>18</sup> for the above events is given in Table 1. It may be noted that the desired targets have been achieved. Since the inception of the warning centre in October 2007 till date, it has monitored and reported 24 tsunamigenic events (under-sea earthquakes with magnitude  $\geq 6.5$ ) in the Indian Ocean region. The model simulations were analysed, real-time water levels were closely monitored and earthquake/tsunami forecasts were issued according to the SOP (Standard Operating Procedure).

Thus India within a very short time have been quite successful in developing the Tsunami early warning systems for Indian Ocean, the benefit of which is also being utilized by many countries surrounding Indian Ocean.

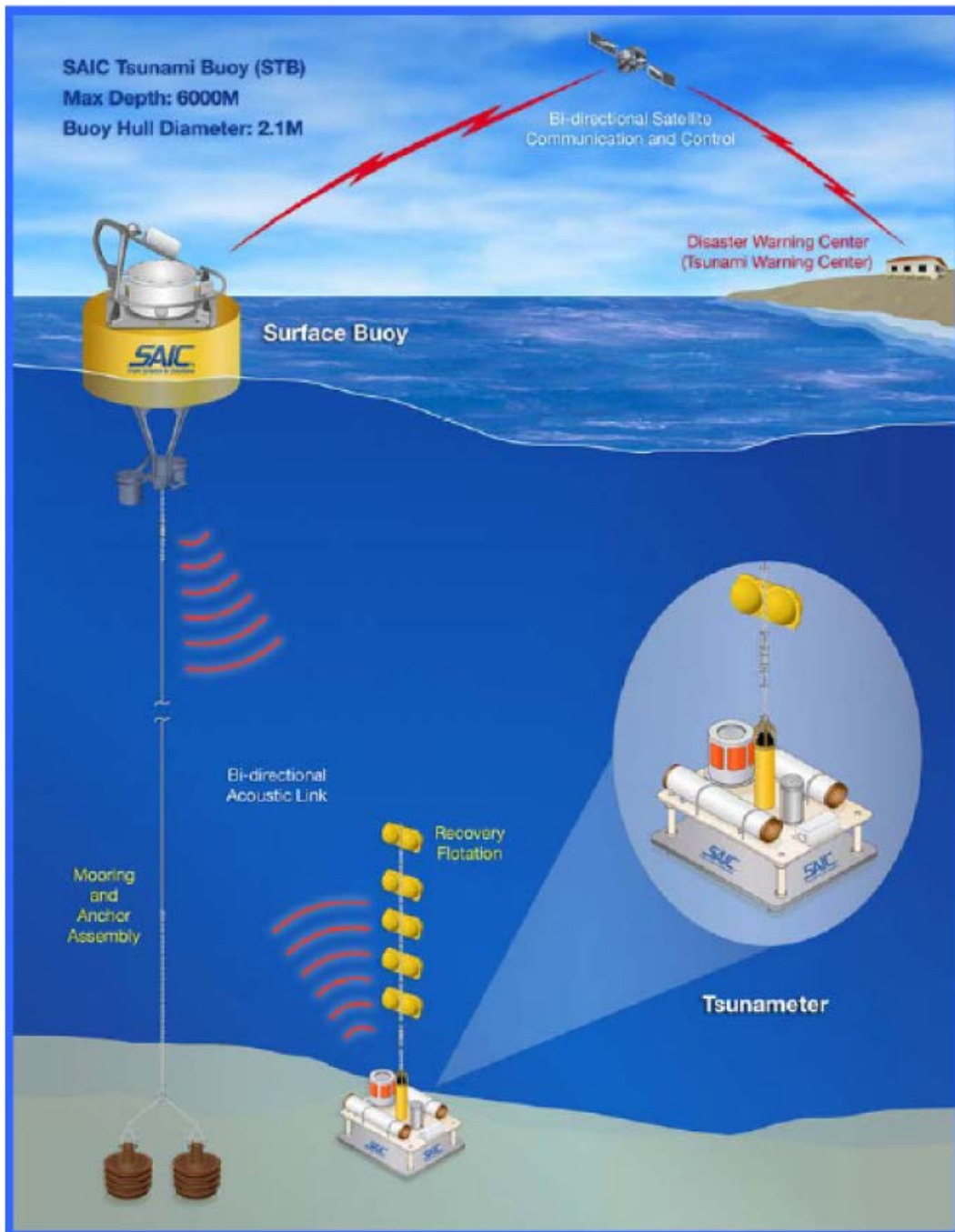

Fig.8

## 8. CONCLUSION

Tsunami is a natural disaster which never comes announced. It is always the result of an earthquake of high magnitude involving tectonic subduction movement of different plates. The key factors to reduce potential losses due to Tsunami are awareness and preparedness. It is quite pertinent to note that during 29th Oct'1999, Super cyclone of Odisha (an eastern state of India) and 26th Jan'2001 earth quake of Gujarat (a western state of India), the people of India and the Government were quite unprepared for such calamities. Hence they had to rely an international help for relief and restoration measures to a great extent. These two exceptional natural calamities had improved the resilience level of the Indians to a great extent. Combined with high economic growth India faced the disaster of the 2004 – Indian Ocean Tsunami (IOT) with little or practically no international aid. Thus “the change for Indians has not only been economical, but also psychological.” Large number of volunteers and NGOs within India came forward for relief and restoration activities. Even India acted as a donor country by sending assistance in the form of relief materials to Srilanka. Moreover the development of Indian Tsunami Early Warning System (ITEWS) after 2004 – IOT with excellent performance at par with other existing global systems is yet another feather on her cap. Thus “India’s response to the Tsunami has been a stepping stone for the country to move out of the world’s periphery” by playing an important role in the centre stage. And by far, this is the greatest impact on India caused by the 2004 Indian Ocean Tsunami.

## ACKNOWLEDGEMENT

The author is grateful to different organizations under Government of India such as National Disaster Management Authority (NDMA), Indian National Centre for Ocean Information Services (INCOIS), National Institute of Ocean Technology (NIOT), National Geophysical Research Institute (NGRI), Integrated Coastal and Marine Area Management (ICMAM) Project Directorate, Indian Meteorological Department (IMD), Survey of India (SOI), Indian Space Research Organization (ISRO), National Remote Sensing Centre (NRSC) and all other organizations relating to Tsunami for getting information, annexures and relevant data pertaining to Tsunami. The author is also thankful to Dr. Ashutosh Mohanty for his article “Report on Tsunami,” Brandon Cramer for his article on “Tsunami’s Impact on India,” which enable the author in writing the article. The article “2004 Indian Ocean Earthquake and Tsunami” collected from Wikipedia, the free encyclopedia was also quite helpful to the author. The author wishes to acknowledge every other source whose names are not mentioned (which is purely unintentional), that has contributed in preparation of this article.



## Marc W. Goldsmith, U.S.A.

### Risk Mitigation in Increasingly Complex Systems

ASME President

E-mail: [MichaudM@asme.org](mailto:MichaudM@asme.org)

#### ABSTRACT

"Today's buildings are taller, ports handle more traffic, energy systems extract more fuel, sanitation systems dispose of more waste, and power grids operate at higher capacity than believed possible a generation ago. Many of today's large-scale, complex systems are interdependent, highly concentrated, and centralized – and too vulnerable to protect against potential threats and failure, whether originating from natural causes, human limitations, or acts of terror. More than ever, engineers need to address low-probability, high-consequence system failures," according to experts with engineering expertise who participated in an initiative summarized in the article "Complexity and Consequences" in *Mechanical Engineering*, December 2011. Companies need to develop comprehensive, integrated approaches to managing risk within and across their organizations. Educators need to incorporate lessons learned from these failures.

In 2010, ASME convened a task force to look at complex systems management across industries and to examine the resources needed for engineers to improve risk management and build resilience against failure in engineered systems. This task force produced a report titled *Initiative to Address Complex Systems Failure: Prevention and Mitigation of Consequences*, in June 2011, focusing on complex systems, specifically on dynamic and far-reaching failures of critical infrastructure, so that engineers can design fault-tolerant systems, assess and manage risk in system operation, and consider the ethical responsibility associated with their management and maintenance.

Recommendations were developed to raise awareness with the general public about the issue of complex systems failure; to develop educational packages for practicing engineers; to produce a compendium of standard risk analysis tools with an accompanying framework for technical complex systems analysis; and to help companies understand, assess, and manage risk within their enterprises. The conclusion of the report makes clear that engineers must take an important step in cultivating a culture that considers risk at every step, making the complex systems we rely on safer for everyone.

## INTRODUCTION

In the wake of natural disasters, technology failures, and terrorist attacks, engineers have a vital, multifaceted role to prevent and mitigate the damage and losses society incurs, to nurture technical literacy throughout society, and to cultivate an engineering culture that considers risk at every step in the design and development of complex systems as well as the decision-making process for sustainable development.

Population growth, economic expansion, resource limitations, and age-related deterioration are placing enormous burdens on the existing critical infrastructure, and the demands placed on engineers will only increase. These demands are being met with the design of new infrastructure systems that are more complex in their development, functionality, and maintenance requirements.

Discounting worst-case scenarios can seem reasonable or economically attractive, but this practice ultimately leads to a culture of complacency that heightens risks. The consequences of any resulting failure from these low-probability, high-severity scenarios may well dwarf any cost savings. These consequences include social, economic, and environmental effects.

Many lessons can be learned from the study and discussion of recent catastrophic events, including failures of the launch of the space shuttle Challenger in 1986; the hurricane protection system following the storm surge caused by Hurricane Katrina in New Orleans, La., in 2005; the explosion at the Deepwater Horizon / Macondo Well in the Gulf of Mexico in 2010; and the impact of Japan's earthquake and tsunami in 2011. And in each case, the question has been raised: Why was critical infrastructure left so exposed to failure?

In ASME's report, one answer bears further discussion: "When a system tolerates a culture in which ignoring risks is perceived to be more beneficial than reducing risks – that system is destined to experience a catastrophic failure."

## SYSTEMS CULTURE TOO LARGE TO FAIL

Efficient infrastructure, while working as designed under anticipated conditions, can become fragile when small discrepancies – such as bad weather or a minor oversight – occur, and these divergences can lead to immediate and total failure when several unexpected events happen at the same time. In ASME's environmental scanning report of 2008 on the *Future of Mechanical Engineering 2028*, six principal systems were cited as key components to lifeline systems, or systems linked to the economic well-being, security and social fabric of communities following catastrophic events. These are, namely, electric power, gas and liquid fuels, telecommunications, transportation, waste disposal and water supply (source: T. D. O'Rourke, *Critical Infrastructure, Interdependencies and Resilience*, National Academy of Engineering, presented at the NAE Annual Meeting in October 2006).

Risk potential also must consider that what is known constantly changes, including population size, urbanization, unusual weather, etc. Advances in science and technology, for example, will improve capabilities for warning systems and increase public expectations, thus increasing design significance. Some resulting consequences need more consideration: Regional damage from Hurricane Katrina, for example, triggered increases in local and national gasoline prices. According to William H. Hooke, if the port of New Orleans had been compromised, countries worldwide would have experienced disruptions in shipments of U.S. grain (source: *Critical Infrastructure, Interdependencies and Resilience*, National Academy of Engineering, presented at the NAE Annual Meeting in October 2006).

According to the report summary in *Mechanical Engineering*: Such large-scale, complex systems are interdependent, highly concentrated, and centralized – and are of such importance that they have been labeled by some as "too large to fail."

While natural disasters, terrorist attacks, and human error will occur, engineers can design complex systems to withstand these threats and help manage risk to reduce the likelihood of cascading failures – while also ensuring that these critical systems do not become too expensive to develop. Engineers have the tools to design and build fault-tolerant systems, to develop diagnostic and prognostic tools that assess the in-situ health of a system and manage risks in system operation, to plan for mitigation in the event of a failure, and to consider the ethical responsibility associated with their safe operation, management, and maintenance. The results of adding built-in redundancies to reduce or mitigate the consequences of failures come with an implied loss of efficiencies and upfront costs for uncertain downstream future consequences. Designers of critical infrastructure, therefore, need to identify and understand the root causes of complex systems failure.

## ROOT CAUSES FOR COMPLEX-SYSTEMS FAILURE

Engineers have been able to identify the key root causes for failure, listed below, according to the summary in *Mechanical Engineering*. Each is related to the need for improvement in the application of systems thinking to the technical engineering sciences as well as to the organizational behavioral sciences:

*Poor development* – This cause of failure can be traced to a lack of organizational commitment to systems thinking. One example of this is a lack of communications between designers and end users.

*Incorrect assumptions with regard to system requirements* – Too often, flawed assumptions made at the initial stages in a system's design will become more than mere suppositions. It is important to continuously challenge mindsets and mental models, even after development has begun.

*Poor user interface* – A system may be elegantly designed, but if it is done without the user in mind and without regard to human factors for safe operation and maintenance, the result can be disastrous. Overly complex user interfaces in both hardware and software systems are common points of failure.

*Faulty hardware and software* – Hardware and embedded software design faults can be overlooked easily in the face of meeting deadlines and budgets. In many ways, this can be thought of as a failure of planning standards or a lack of shared standards development and enforcement.

*Inadequate user training or user error* – Failures due to a lack of training should not be considered the fault of the individual operator, but as a blunder in foresight by management. Improved training of end users has been shown to significantly reduce system failures and improve the integrity of systems.

*Unintended interactions* – Complex systems often have so many connected parts that the interactions between them are nearly impossible to fully anticipate. The result is a non-linear, cascading (and often catastrophic) response to failure of what had been thought to be an independent component of a system.

*Lack of public awareness* – It is human nature for both elected officials and the public to disregard the fact that ubiquitous complex systems have a likelihood of failure and that these failures must be addressed proactively. As a result, preventive efforts do not receive the attention and resources they need.

*Lack of attention in engineering training* – Risk assessment (both theory and practice) is underemphasized because it exposes the vulnerability of a system to potential threats. The avoidance of identifying system vulnerabilities promotes a culture in which ignoring risks is perceived to be more beneficial than reducing risks.

For most accidents, three circumstances need to have occurred: human operating error, failure to construct to standards and lack of management clarity.

## LESSONS TO BE LEARNED FROM FAILURE

A few examples help demonstrate these root cause and point the way toward lessons learned:

*Space shuttle Challenger (51-L) on January 28, 1986* – Knowledge by engineers at mid-levels in the organization (regarding problems with the o ring seals in the solid rocket booster when ambient temperatures were below freezing) was not communicated up the management chain, and therefore the decision to launch was flawed, according to the *Report of the Presidential Commission on the Space Shuttle Challenger Accident*, June 6, 1986. The Commission cited specific factors such as the effects of temperature, physical dimensions, the character of materials, the effects of reusability, processing and the reaction of the joint to dynamic loading. The ultimate design lesson learned, however, may have been part of R. P. Feynman's personal observation (as a part of this accident report), "For a successful technology, reality must take precedence over public relations, for nature cannot be fooled."

*Storm surge from Hurricane Katrina in New Orleans, August 2005* – Key among the causes was the piecemeal design of a complex system over long periods of time. The storm surge caused more than 50 breaches in drainage canal levees and also in navigational canal levees, flooding approximately 75% of metropolitan New Orleans (with damage to a 200-mile storm front across Gulf coastal area). According to John T. Christian, a consulting engineer from Waban, Massachusetts, in a presentation at the NAE Annual Meeting in October 2006, both geotechnical conditions and design flaws contributed to the failure of the levees in New Orleans. Christian cites a detailed study of the geodetic levels that revealed confusion and error, resulting in two different benchmark levels used in creating the levee system.

*Deepwater Horizon drilling rig at the Macondo Well in the Gulf of Mexico, April 20, 2010* – Drilling malfunctions caused more than four million barrels of oil to spill unimpeded into the Gulf, according to the report of the appointed Oil Spill Commission: "The immediate causes ... reveal such systematic failures in risk management that they place in doubt the safety culture of the entire industry." Also cited in the introduction of the report was the comment: "As the Board that investigated the loss of the Columbia space shuttle noted, 'complex systems almost always fail in complex ways.'"

This industry-wide call for change also was a high priority in the recommendations from the report *Engineering a Safer World: Systems Thinking Applied to Safety*, (by MIT Professor Nancy Leveson, from the Hearing on Risk Management in Oil Industry, for the US Senate Committee on Energy and Natural Resources, May 17, 2011), which include improved industry standards, industry self-policing, implementation of safety management systems, integration of safety engineers into operations decision-making, certification and training, learning from events, hazard analyses maintenance, third-party certification and incentives to change the safety culture.

*Storm forces and flooding in the aftermath of Japan's earthquake and tsunami March 2011* – Causing great loss of life and property and devastation to the environment, this event also notably led to severe nuclear plant damage and radiological releases at the Fukushima Dai-ichi station. The Fukushima Dai-ichi accident reveals no fatal flaw in nuclear technology, yet multiple important safety improvements are being addressed by the global nuclear fleet from the lessons learned. Key reasons for destruction are the now-recognized inadequacies in plant design basis for tsunamis, flooding, and accident management.

A team of ASME leaders has been engaged with Japan Society of Mechanical Engineering (JSME) colleagues in working on the potential impact of these events on nuclear codes and standards since spring 2011, and it continues to identify broader lessons learned, as well as its potential impact on worldwide energy portfolios and nuclear power deployment. On that basis, the ASME Task Force has proposed recommendations in the recent report on *Forging a New Nuclear Safety Construct*, which is now available online at ASME.org. The report resulted from leadership by ASME's task force on a "Response to Japan Nuclear Power Plant Events," plus a task group for a "Design Basis and Response to Severe Accidents."



## EDUCATIONAL VALUE OF LESSONS LEARNED

All technologies have risks to public health and safety, either along the delivery chains or through normal operations. As technologies reach industrial scale, the negative impacts and risks become more apparent. Cliff-edge events – those for which a small incremental increase in severity can yield a disproportionate increase in consequences – can be discovered and mitigation approaches implemented. Engineers need to address these issues for preventing failure, understanding vulnerabilities, identifying and quantifying threats, reducing the probability and frequency of failure occurrence, and mitigating the consequences. During a crisis, engineers should be perceived as adhering to a strong code of ethics, inculcated as educational and professional core values.

Gary P. Halada, associate professor at Stony Brook University, New York, reports that lessons learned from life examples give engineering students in the classroom a sense of broader socio-economic implications. His examples of coursework using lessons from engineering failures meets the ABET Student Outcomes criteria (2010-2011) in ethics; understanding the impact of engineering in a global, economic, environmental and social context; contemporary issues; and lifelong learning. Advanced undergraduate courses, graduate programs and some industrial continuing education programs can offer systems design approaches, but even just a few years ago, ASME's 2028 futures report suggested that traditional engineering curriculums still teach simple systems. To teach ethical, legal and societal implications of engineering, curriculums need to incorporate an understanding of the difficulties inherent in probabilistic risk assessment for large, dynamic complex systems; the role of human factors; and the lessons risk assessment and engineering failures.

## ASME RECOMMENDATIONS

The conclusion of ASME's report on complex systems failures has four areas of focus for recommendations from the ASME task force:

*Communication and Advocacy* – Increase public and political awareness of what can be done to help prevent such failures from occurring.

*Education* – Develop a set of educational materials about preventing, reacting to, and mitigating complex systems failure for use by educators and practicing engineers.

*Enterprise Risk Management (ERM) Framework* – Enable companies to develop a comprehensive, integrated approach to managing their enterprise risk to minimize the potential for complex systems failures and to develop plans to react and mitigate consequence.

*Risk Analysis Tools* – Develop a compendium of diagnostic and prognostic risk analysis tools and a capability that industries can use to tailor to their situation and environment, allowing them to effectively assess risk.

## GLOBAL UNITY IN THE ENGINEERING CULTURE

The future development of any technology can depend on an unlikely event happening. Greater or broader international or cross-border understanding of the consequences of complex failures is necessary to assure effective accident negation. Also needed are pre-training and established collaborative relationships to manage the effects. There is a strong need for global unity and engineering excellence.

In conclusion, for the sake of the public, for engineering as a profession, and for the world – engineers must cultivate a culture that considers risk at every step in the design, fabrication and operation of complex

systems on which we rely. Engineers will be building cities and rebuilding the aging infrastructure of cities throughout the world, while adapting to new technologies, using new materials, establishing new standards, and increasing efficiencies. Engineers have both the obligation and opportunity to build better, safer cities that improve the lives of people.

## ACKNOWLEDGMENTS

Authors of ASME's report *Initiative to Address Complex Systems Failure: Prevention and Mitigation of Consequences* are Harry Armen, Shannon Flumerfelt, Gary P. Halada and Franz-Josef Kahlen. Harry Armen, a past president and Honorary Member of ASME, retired as chief technologist for the eastern region of the integrated systems sector of the Northrop Grumman Corp. Shannon Flumerfelt is an endowed professor of Lean and director of Lean Thinking for Schools at The Pawley Lean Institute at Oakland University in Rochester, Mich. Gary P. Halada is an associate professor in materials science and engineering at Stony Brook University in New York. Franz-Josef Kahlen is associate professor in the Department of Mechanical Engineering at the University of Cape Town, South Africa. These authors summarized the report in a December 2011 article in *Mechanical Engineering* magazine, titled "Complexity and Consequence," which has been used with permission (copyright 2012).

In addition, this presentation benefits from meeting presentations by participants such as Harry Armen and Gary Halada, as well as Philip Grossweiler, director of Special Projects, M&H Energy Systems, at the Forum on Disaster Prevention and Mitigation, Sino-American Technology & Engineering Conference 2012, sponsored by the Chinese Academy of Engineering, April 21, 2012.

## REFERENCES

- Armen, Harry, ASME Past President, Response and Prevention of Disasters, presented to the Forum on Disaster Prevention and Mitigation, Sino-American Technology & Engineering Conference 2012, sponsored by the Chinese Academy of Engineering, April 21, 2012.
- Christian, John T., "Lessons from Hurricane Katrina," *The Bridge*, Spring 2007, National Academy of Engineering, retrieved 12/03/07, www.NAE.edu, presented at the NAE Annual Meeting in October 2006.
- Forging a New Nuclear Safety Construct*, available online at ASME.org.
- Grossweiler, Philip, Director of Special Projects, M&H Energy Services, Reducing and Mitigating Risk on Energy Projects Integrating Lessons Learned from the 2010 Gulf of Mexico Spill, presented to the Forum on Disaster Prevention and Mitigation, Sino-American Technology & Engineering Conference 2012, sponsored by the Chinese Academy of Engineering, April 21, 2012.
- Halada, Gary P., Associate Professor, Department of Materials Science and Engineering, Stony Brook University, New York, Teaching by Disaster: The Ethical, Legal and Societal Implications of Engineering Disaster, presented to the Forum on Disaster Prevention and Mitigation, Sino-American Technology & Engineering Conference 2012, sponsored by the Chinese Academy of Engineering, April 21, 2012.
- Hooke, William H., "Engineering for the Threat of Natural Disasters," Editor's Note, *The Bridge*, Spring 2007, National Academy of Engineering, retrieved 12/03/07, www.NAE.edu, presented at the NAE Annual Meeting in October 2006.
- Initiative to Address Complex Systems Failure: Prevention and Mitigation of Consequences*, published June 2011 by ASME.
- Leveson, Nancy, MIT Professor, *Engineering a Safer World: Systems Thinking Applied to Safety*, from the Hearing on Risk Management in Oil Industry, For the US Senate Committee on Energy and Natural Resources May 17, 2011.
- O'Rourke, T.D., "Critical Infrastructure, Interdependencies and Resilience," *The Bridge*, Spring 2007, National Academy of Engineering, retrieved 12/03/07, www.NAE.edu, presented at the NAE Annual Meeting in October 2006.
- The Presidential Commission on the Space Shuttle Challenger, Accident Report*, June 6, 1986, in compliance with Executive Order 12546 of February 3, 1986 (<http://history.nasa.gov/rogersrep/genindex.htm>).

# **Green Buildings**



# Vincent Briard, France

## Knauf Insulation

Environmental Performance Matters, what Impacts  
on the Construction Sector

E-mail: [vincent.briard@knaufinsulation.com](mailto:vincent.briard@knaufinsulation.com)



## REPLACING GREENWASH WITH ENVIRONMENTAL PERFORMANCE – MAKING BUILDING TRULY GREEN

It's been a long time coming, but the concept of green building is finally taking off across Europe. Demand for green or sustainable construction has grown 50% in the last two years<sup>1</sup> and looks set to increase even more in the near future. Given the global imperative to tackle energy security and climate change, and the huge impact that buildings have on our environment, Europe has enough reason to put in place robust policies that change the way we plan and design our built environment. Actually, buildings account for 30-40% of energy use worldwide<sup>2</sup> and in Europe they consume more than 50% of all extracted resources and are responsible for 35% of greenhouse gas emissions<sup>3</sup>.

When it comes to improving the energy efficiency of buildings, governments are already gearing up. The 2009 recast of the Energy Performance of Buildings Directive (EPBD) has already started to impact the way we design buildings, and it is expected (if the EPBD is properly implemented by the member states) that in less than 10 years, all new buildings in Europe will be "nearly zero energy". If the EU and its member states could only be as ambitious about existing buildings, through the implementation of deep renovation plans, Europe could reduce the levels of energy consumption of the building stock for space heating in 2050 by 80% compared to 1990<sup>4</sup>, which would significantly contribute to the 90% GHG reduction target set by the EU in its "Roadmap for moving to a competitive low carbon economy in 2050".

Europe has therefore correctly chosen to concentrate first on improving the energy performance of buildings through the EPBD and its implementation, but now "*we need complementary policies - resource efficiency, which look at a wider range of environmental impacts across the life-cycle of buildings and infrastructure*"<sup>5</sup>.

To explain, when looking at energy for example, which is responsible for the lion's share of the environmental impact, it's necessary to realize that where construction products previously represented a small proportion of the total energy consumption of the building (8% in the example below), in the future, their impact will grow to account for almost 50% of the total energy consumption over the lifetime of the building. And what applies to energy, would apply in a similar way for all other environmental indicators.

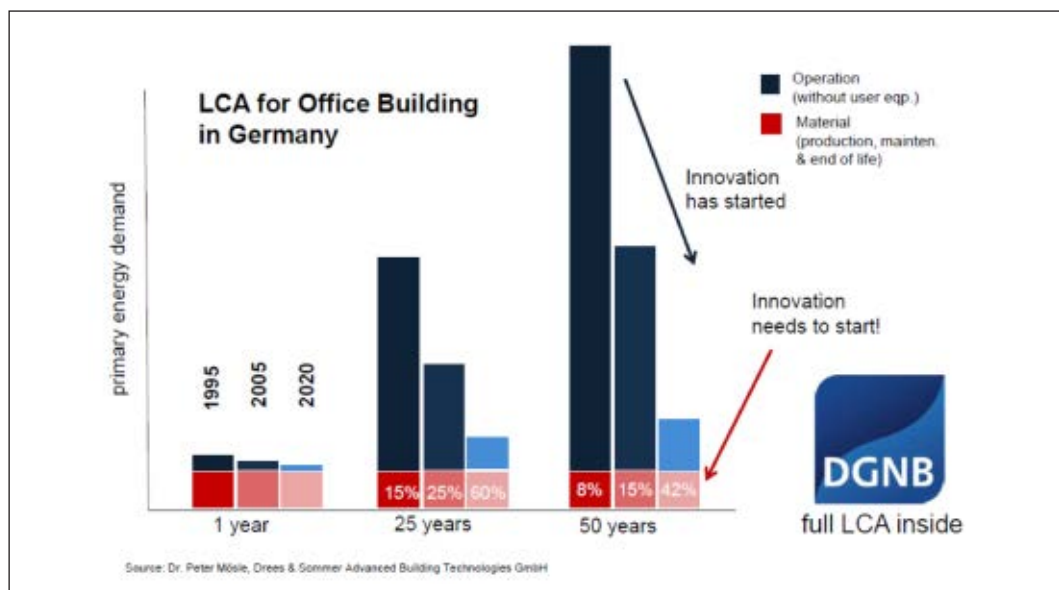

As already mentioned, the development of sustainable buildings and construction products is on its way, but the whole building chain is realizing that it is a challenging task, because of the great variety of criteria and actors.

For example, one of the issues is the growing emergence of eco or green labels, many of which apply to construction products. There is an interesting recent survey on this topic: [www.ecolabelindex.com](http://www.ecolabelindex.com). Due to a lack of transparency and the sheer number of labels available, these seemingly attractive eco-labels available for various stakeholders (in particular, but not only, households) actually indirectly contribute to green-washing the construction related decision making processes.

Another dimension of the challenge is related to the principle that real environmental impact of construction products can only be assessed at the building level, as for most of them it is the performance of the system in which they are incorporated and its functionalities, that matter. For example, if you take insulation products the first priorities are to define the application (flat roof, external walls, pitched roof ...) and to understand the requirements (hygrothermal, mechanical, fire ...). It is only when selecting the possible systems that meet these characteristics that the environmental impact can be assessed and possibly compared.

Against this backdrop, 'summarized as ... *making building truly green*', we believe the best methodology for this kind of impact assessment is to use standardized Life Cycle Assessment (LCA) methods. LCA means breaking down the life cycle of products, systems or buildings into basic phases from "cradle to gate" or "cradle to grave" and quantifying, on the base of a number of standardized indicators, their environmental impacts. Through this method, aggregation at building level is made possible. And as such, LCA is one of the only reliable tools to be able to assess the green credentials of a building and enable those in the construction industry to make the right choices both now and for the longer term. Furthermore, the recent publication of the standards EN 15804 and EN 15978, which apply respectively to products and buildings, encourages all EU countries to harmonize their assessment methodologies and this unifying methodology needs to be the comprehensive assessment that is LCA.

The graph below illustrates the results for one indicator - Global Warming Potential, for a number of insulation products which are used in different applications<sup>6</sup>. We clearly see that, while all products are made of glass mineral wool, their impact range from almost 1 to 6, depending on product design, hence functionalities. We also see that the "production stage" is, for glass mineral wool, the most critical one (almost 70% of the total impact).

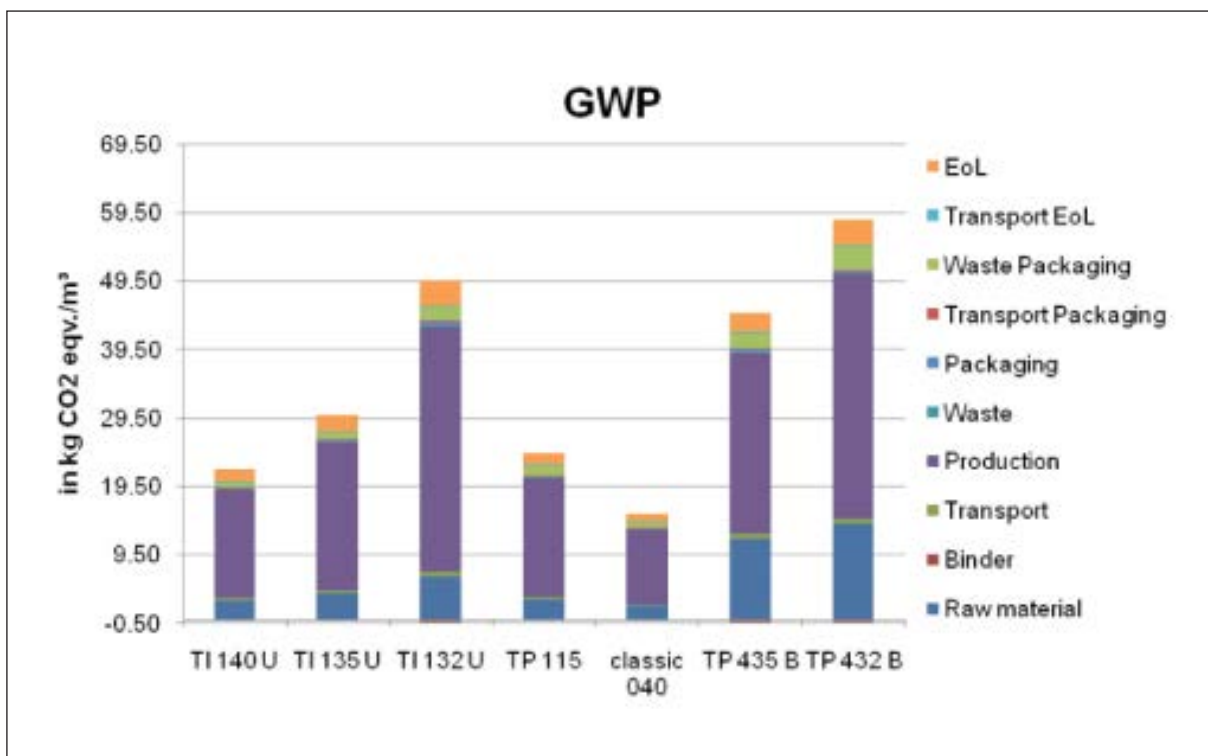

LCA not only contributes to the evaluation of the true environmental impact of the building, but it also allows construction products / systems manufacturers to go back to their manufacturing and design teams with a great level of details (not presented in this paper) in order to improve processes and lower the impact. This is commonly called "ecodesign". Furthermore, in Europe, the environmental credential of construction will soon be part of the mandatory CE marking, which we consider as an essential step towards well-needed transparency.

From products to buildings; when considering the activity ahead in the construction sector, new and renovation in Europe, and also the drastic rise in urbanization in the developing world, resulting in a huge demand for dwellings in particular, we have a stronger than ever case to focus on sustainability in the building sector.

There are a number of initiatives, from global to EU, but also national or local, from regulatory to non-governmental initiatives but also commercial schemes, and it is key that, when considering the environmental, social and economic performances of buildings, the assessments are based on "life cycle thinking". Unfortunately, this is not always the case. As such, it is our wish that the work done in CENTC/350, Sustainability of Construction Works and implementation of the developed standards, will contribute to this aim.

So what does this mean? At Knauf Insulation, we believe that this means improving the sustainability of building at every stage of its life cycle – from design to commissioning, from very high level of energy performance requirements to well monitored health and comfort performance, from using renewable or recycled resources and minimizing the use of regulated chemicals in products, to ensuring that buildings are properly demolished using established recycling routes.

To conclude, for the construction sector, making LCA's central to the EU's own Resource Efficiency efforts (EU 2020 Flagship Initiative) would ensure that policy makers had the correct information to be able to decide where to focus efforts and enable companies to communicate credible and fact-based information about their products to European consumers and target their own resource efficiency improvements, strengthening the European construction industry as a whole whilst aiming at a better built environment.

Vincent Briard is Head of Sustainability, Products and Buildings at Knauf Insulation. Industrial Engineer by education, he has held several leadership positions in the manufacturing environment. For many years, he actively collaborated with the EU Association of Insulation Manufacturers to energy performance of buildings programs particularly focusing on European policies and frameworks. His function, now, is integrated in the Central Marketing organization of Knauf Insulation with overall responsibility on the sustainable development of products and processes, and buildings; this implies special focus on LCA, EcoDesign, building rating ... tools. Vincent is actively involved in several EU initiatives working with stakeholders from across the EU to support the transition to more sustainable built environment.

## ENDNOTES

- 1 *"Green Outlook 2011" - MCGRAW-HILL CONSTRUCTION*
- 2 *International Energy Agency (IEA)*
- 3 *Roadmap to Resource Efficient Europe*
- 4 *Ecofys study for Eurima, Renovation tracks for Europe 2012*
- 5 *EU Commission, DG Environment*
- 6 *Knauf Insulation EPD's published on IBU (Germany)*



# Gerald Fuxjäger, Austria



## Life Cycle Cost

Chamber of Architects and Civil Engineers of Styria  
and Carinthia

E-mail: [armin.ruhri@ztkammer.at](mailto:armin.ruhri@ztkammer.at)

### ABSTRACT

In its Green Paper on Energy Efficiency, the European Commission (EC) identified the building sector as an area, where important improvements in energy efficiency can be realised. According to the Green Paper, the building sector accounts for more than 40% of the final energy demand in Europe. At the same time, improved heating and cooling of buildings constitute one of the largest potentials for energy savings. Such savings would also improve the energy supply security and the EU's competitiveness, while creating jobs and raising the quality of life.

The GreenBuilding Program (GBP) is a voluntary program started from the EU. It is meant to enhance the realisation of cost-effective energy efficiency potentials by creating awareness and providing information support and public recognition to companies.

The GreenBuilding Partner has to try to search for intelligent ways to reduce the energy consumption. The architects and chartered engineering consultants are reliable and independent partners to find these ways.

## The Federal Chamber of Architects and Chartered Engineering Consultants

is the representation of the professional, social & economic interests with following tasks

- information on building regulations,
- promotion of collegiality and interdisciplinary cooperation,
- improvement of the professional knowledge and conditions and
- disciplinary action, insurance and service

### International Memberships

<b>ACE</b>	- Architects' Council of Europe
<b>ECEC</b>	- European Council of Engineers Chambers
<b>EFCA</b>	- European Federation of Engineering Consultancy Association
<b>FIDIC</b>	- International Federation of Consulting Engineers
<b>GE</b>	- Geometer Europas
<b>CLGE</b>	- The Council of European Geodetic Surveyors

## Architects and Chartered Engineering Consultants

The **authorisation for professional practice** is awarded by the Austrian **Federal Minister of Economics**.

The **authorisation enables** architects and chartered engineering consultants for their entire expert areas

- ✓ to provide **planning, inspecting, monitoring, advising, coordinating, mediating, fiduciary services,**
- ✓ to **conduct surveys,**
- ✓ to **establish public documents,**
- ✓ to **provide professional representation** in negotiations with authorities and public corporations,
- ✓ to **work in the organisational and commercial development of projects** and
- ✓ to **undertake complete planning contracts**

**A part of the work from the architects and chartered engineering consultants is to make buildings GREEN.**

**This will mean, using regenerating raw materials, including renewable energy in the planning of city infrastructure, increasing the share of renewable energy and improving the energy performance in buildings and industry.**

**While buildings are the biggest consumer of energy, they also have the greatest potential to reduce the conventional consumption.**

## Life cycle cost

The International Standards Organisation (ISO) defines lifecycle costs as **“the cost of an asset throughout its lifecycle while fulfilling the performance requirements”**.

Lifecycle costing is basically a simple concept – it answers the question: **“If I build this building, what future costs will I be letting myself in for?”**

It is not difficult, but it is complex because potentially there is a huge number of costs to consider. In the longtime forecast it is complicated how to treat the effects of inflation and lost investment opportunities.

**The cost structure is based on conception, planning, construction, maintenance, operation and end of life (Demolition and Decommissioning Costs).**

## Life cycle cost of a building

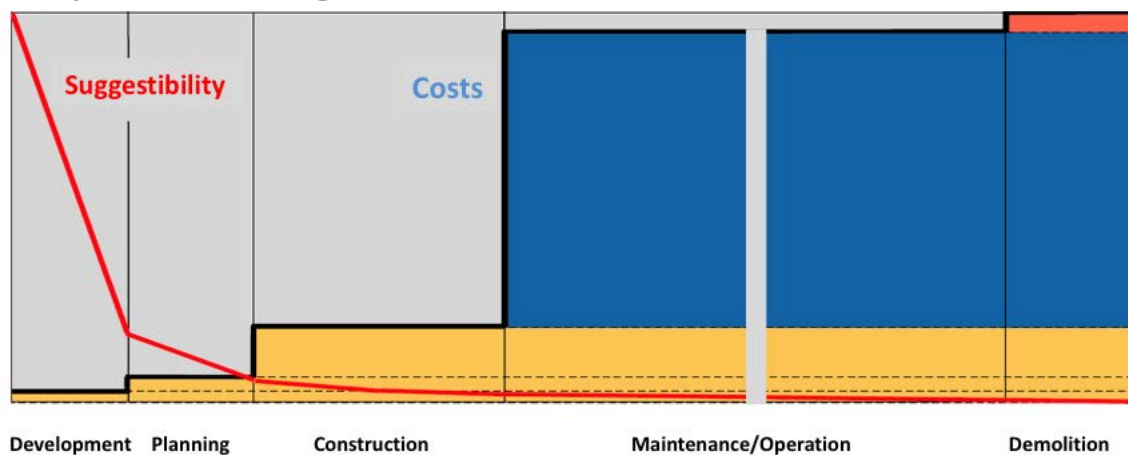

## Life cycle cost of a building

The individual parts of the costs in the life cycle of a normal building are to be evaluated about following:

- Development / Planning           ca. 2 - 5 %
- Construction                       ca. 10 - 20 %
- Maintenance/Operation           ca. 70 - 80 %
- Demolition                         ca. 2 - 5 %

**The largest part of it are the subsequent costs (Maintenance/Operation) will be ca. 70 % to 80 %. Half of it (ca. 35- 40%) is spent for energy (heating, cooling, lighting, warm water).**

### Life cycle cost of a building

Heating, cooling, lighting systems and warm water have major impacts on the energy consumption in buildings.

The energy consumption for heating in the European Union represents about 52 % of the total energy consumption in service sector buildings – in the residential sector it is even more with 57 %.

Air-conditioning is the most important reason for increasing energy consumption in non-residential buildings; the additional primary energy consumption due to cooling of an office adds up to + 32%.

Lighting has a substantial impact on the energy consumption in non-residential buildings, accounting for up to 1/3 of the electricity used in some office buildings, for example.

### GREEN BUILDINGS PROGRAM

In its Green Paper on Energy Efficiency, the European Commission (EC) identified the building sector as an area, where important improvements in energy efficiency can be realised.

According to the Green Paper, the building sector accounts for more than 40% of the final energy demand in Europe.

At the same time, improved heating and cooling of buildings constitute one of the largest potentials for energy savings.

Such savings would also improve the energy supply security and the EU's competitiveness, while creating jobs and raising the quality of life.

### GREEN BUILDINGS PROGRAM

The GreenBuilding Program (GBP) is a voluntary program started from the EU.

It is meant to enhance the realisation of cost-effective energy efficiency potentials by creating awareness and providing information support and public recognition to companies.

The GreenBuilding Partner has to try to search for intelligent ways to reduce the energy consumption. The architects and chartered engineering consultants are reliable and independent partners to find these ways.

### GREEN BUILDINGS PROGRAM GOALS

The main objective of GreenBuilding is to **trigger investments in energy efficiency and renewable energy technologies in non-residential buildings** with focus on existing premises on a voluntary basis.

GreenBuilding is designed to help to **open up markets** – in particular by increased awareness, know-how and technical capabilities, the access to finance and energy service offerings – to achieve investments with high benefits and short payback times.

GreenBuilding wants to initiate energy efficiency investments in non-residential buildings which are clearly **profitable and are based only on proven technologies**.

### GREEN BUILDINGS PROGRAMM GOALS

GreenBuilding complements and goes **beyond the standards imposed by the European building directive and national building codes** in force.

By encouraging energy efficiency and renewable energy measures which are economically viable, GREENBUILDING actively **contributes to the advancement of the state-of-the-art in energy saving techniques** in the building sector.

GreenBuilding intends to **provide information and support as well as public recognition** to companies, which are ready to make commitments to improve the energy efficiency of non-residential buildings well beyond the legal requirements with measures that are proven and profitable.

### GREEN BUILDINGS TREND

The reports of the building industry qualify **GREEN BUILDING** as THE growth industry.  
**Without lastingness buildings in the EU will no longer be profitable in the market.**

**For the holistic view you will need special know-how for substantial climatological -, energetic-, thermal-, aero-procedures, also for construction physics and product properties.**

**Austrian architects and chartered engineering consultants have this special know-how of green building technologies !**

## GREEN BUILDINGS IN STYRIA



2004 pos architekten / Hochschwab



2005 Arch. DI Kaltenegger / Gleisdorf



2006 Arch. DI Kaltenegger / Gutenberg



2010 arch+more / Neumarkt

## **Dr. Ljudmila Koprivec, Slovenia**



### **The Influence of Contemporary Materials and Technologies on the Building Envelope**

Trimo, d.d.

E-mail: [ljudmila.koprivec@guest.arnes.si](mailto:ljudmila.koprivec@guest.arnes.si)

#### **ABSTRACT**

The theme deals with the contemporary building materials and technologies and their influence on the building envelope. Contemporary materials and technologies are of crucial importance for the future of the building envelope. New classes of materials (smart materials, nanomaterials and biomimetic materials) represent an important deviation from the conventional classes of building materials as well as from the conventional concept of the building envelope. The evolution of the façade is presented through three evolutionary phases, while the fourth evolutionary phase is about to begin. Crucial pointers for the further development of the contemporary façade are highlighted: technological factors, economic impact, and aesthetic influences. Examples of innovations in Slovene construction industry - new façade systems of the Trimo d.d. company are presented.

## INTRODUCTION

Sustainable architecture has the ability to respond. It responds to the macro environment that is defined by nature's environmental changes and to the micro environment that is defined by the user's needs. Its flexibility enables possible changes in the intended purpose of space use. It respects the utilization of space as a limited source that is achieved by the renewal of the existing building fund and with magnification of the net surface in new constructions. Its economic and ecological value is foreseen with the reduced investment and maintenance costs of the whole building life cycle. Sustainable architecture enables pleasant living environment for the inhabitants and insures healthy micro-climate of the interior architectural space. This is achieved with respect to the surrounding of the build and natural environment, climate aspect, smart cooling and heating systems, utilization of natural light and energy efficient materials, whereby the return of investments, retrofitting solutions are foreseen. Fast technology development in the 21. Century, interdisciplinary research and increased collaboration between industry, institutes, university, architects and designers offer new challenges in designing the facade and its application in the sustainable construction sector.

## MODERN BUILDING ENVELOPE

The facade envelope is an important element in architecture that physically separates the interior from the exterior and defines the building's communication with surrounding public space. Although the façade has often changed in the history of architecture, it maintains its role as a boundary between internal and external space and gives shelter and protection to people.

Historically, the concept of the facade went through three main evolutionary phases: from the load-bearing massive wall, through skeleton construction to the non-bearing wall, upto the contemporary dematerialized façade. We can interpret today's technological development of the façade as the sequence of these three development stages (Koprivec, 2009). To the standard facades, which had besides a functional role had also a strong symbolic meaning, new facades are added. Today novel properties such as minimizing thickness, high insulation capacity, air and water tightness, active surfaces, energy generation or even a phenomena and attraction are inherent properties to the modern façade (Fig.1).

a)



b)

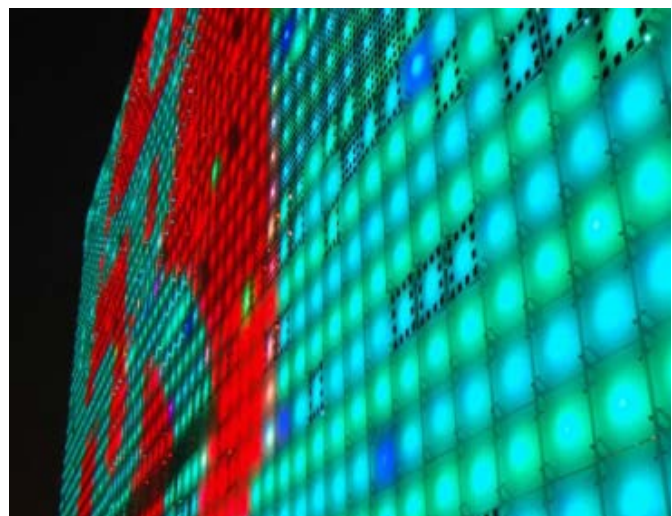

Fig.1: a) Zollverein School of Management and Design, Essen; SANAA, 2006: To keep the facade as thin as possible, the architects did away with conventional insulation in the building's outer walls. Instead, naturally available warm water is pumped through pipes set into the concrete, stabilizing the internal temperature (<http://www.domusweb.it/>).



b) GreenPix Zero Energy Media Wall, Peking; Simone Giostra & Partner and Arup, 2008: Media wall behaves like an organic system, absorbing solar energy during the day and then generating light from the same power that evening (<http://www.dezeen.com>).

There are various factors that define the development of the building envelope.

Technological factors that are influencing the development of the façade are new systems of supporting structures of a better quality, increased usage of new adhesive techniques, better joining and sealing techniques. With the application of new materials and new technologies the size of the façade's formats are increasing while lowering the weight of the façades. These factors are encouraging the possibility of façade's exchangeability and the flexibility of the façade system.

In addition to these "static" properties the technological influence results in new, "active" properties of the building envelope. New processes such as energy generating, self-cleaning activity, anti-corrosion activity, even self-healing are defining the development of the building skin.

Fashion indicators have been always present in the history of architecture. Today's fashion industry is a fundamental driver of consumerism. Just like in the textile industry the rapid development and wide variety offers are present in the modern architecture. Architectural technology follows the rapidly changing trends to maintain competitiveness in the market. New symbolic, fashion indicators and the unification of façade's elements have key influence on the façade's development (Koprivec, 2009).

Economic influence on the façade's development is resulting in lower costs for investment and maintenance, ecological considerations, consumerism and globalization. With the application of new materials and technologies the design of sustainable façade elements is possible, with properties such as durability, higher life expectancy, self-cleaning properties, that all reduce the maintenance costs. Reducing the mass of the façade elements, minimizing construction times, reducing energy for production of the façade element, prefabrication and fast assembly are reducing investment price.

### Prefabricated facade systems

Modular, prefabricated façade systems today are meeting high aesthetic standards that enhance the architect's creativity (Fig.2). CAD/CAM technologies allow the design and production of prefabricated elements in a controlled environment that increases the quality and the durability of the product, economic use of materials and hence lower investment costs, as well as modern production methods, such as robotic manufacturing. The strategy for planning and designing allow architects to use them in different building types: various public buildings, industrial buildings and as well in the areas of housing.

a)



b)



c)



Fig.2: a) Trimo Pavilion, Trebnje, Slovenija: Innovative, light, thin and highly insulative (gas-filled) prefabricated elements offer flexibility in design by combining different materials (glass, composites), colors and individual graphic effects of external façade plate (archive Trimo, d.d.).

b) Prefabricated façade elements allow economic assembly whilst increasing the durability of the façade system. Pre-fabricated elements consisting of two galvanized and pre-finished steel sheets are bonded to the core, which is made of non-combustible mineral wool. All elements are produced by automated, robotic production process (archive Trimo, d.d.).

c) Condominium housing, New York: The ability to produce a large portion of the building off-site (in this case the concrete and brick panels) allowed for considerable ecological benefits as well as economical ones. BIM, Revit and parametric software were utilized to create various innovative forms with brick (<http://lgbehen.files.wordpress.com>).

## NEW TECHNOLOGIES

The denial of tectonics and dematerialization are phenomena that have already changed the contemporary architecture. The usage of new computational techniques has contributed enormously to the architectural design. With CAD/CAM technologies new geometry can be performed enabling the formation of new architecture or building envelope. The increased use of contemporary software in designing, production as well as in the realization of façades, is offering better quality of the façade systems, faster and economical building methods (Zbašnik, Koprivec, Kresal, 2011).

## NEW MATERIALS

Interdisciplinary research in last year's and fast evolving technologies gave rise to the introduction of new building materials and technologies in the field of architecture and at the same time led to an upgraded classification of building materials. Contemporary materials that are or could be used in facades are generally formed in two groups: the conventional materials with improved properties and new materials such as nanomaterials, smart materials and biomimetic materials.

### Conventional materials with improved properties

Novel and improved properties are gained through specific procedures of production and processing of conventional materials. Besides the usual characteristics new properties such as lower weight, increased strength, increased durability, increased dimensions and new visual properties are obtained (Zbašnik, Koprivec, 2011). Stone, ceramic, glass, concrete, metals, wood and other materials of organic origin, technical textiles and polymers, acquire fresh possibilities of utilization.

### Smart, Nano, and Biomimetic materials

The main property of Smart Materials is their inherent intelligence and fast reaction to the external or internal influences. Their activeness is shown with change of their properties or conversion of energy (Addington, Schodek, 2005). Smart Materials that are already used in the building envelope are LED, Photovoltaics, PCM, Electrochromic glass, etc. Many Smart Materials like shape-memory alloys, shape-changing gels, rheological fluids, etc. that are used in other branches are still searching for their place in the building envelope.

Properties of nanomaterials are stemming from their nanoscale dimensions. Nanomaterials can add functional characteristics and novel sensing properties such as structural health monitoring, increased

tensile strength, self-cleaning capacity, fire resistance, and many other capacities like heat absorbing windows and energy coatings taking building materials (coatings, panels and insulation) to a maximum capacity of performance in terms of energy, light, security and intelligence (<http://www.cnt-ltd.co.uk/nano/nanomaterials-in-architecture>).

Over the last few years, biomimetic has established itself as an independent field of science. Learning from nature has now become a guideline for all industry branches (Zbašnik, Koprivec, 2010). Utilization of biochemical processes in building components, generating biomass and heat, absorbing CO<sub>2</sub> and providing adaptive shading is one research of bio-reactive building envelope (<http://smartgeometry.org>, 2012).

Nature offers countless treasures for the implication to energy efficient systems that, when adapted to facades, present novel and innovative concepts (Bauer, 2010).

## CONCLUSION

Global, economic crisis that we are witnessing today opens new questions and challenges in the development of architecture: How are people going to live in the next few years? How energy-efficient systems can be achieved? How to optimize the usage of the architectural space in new construction and how to approach to the renovation of the existing building fund? How to achieve optimization and higher quality in all architectural processes? With application of new technologies into the building sector and global energy-usage demands, architects are forced to improve and broaden their knowledge to be able to answer some difficult questions about the future development of architecture. It is becoming more apparent that the next technological frontiers will be opened not through a better understanding and application of a particular material, but rather by understanding and optimizing material combinations and their synergistic function (<http://ec.europa.eu>) that can open new possibilities for a building envelope of a sustainable build environment.

## REFERENCES

- Addington, M., Schodek, D., (2005): *Smart Materials and Technologies for Architecture and Design Professions*. Elsevier Ltd., Amsterdam, Boston, Heidelberg, London, New York, Oxford, Paris, San Diego, San Francisco, Singapore, Sydney, Tokyo.
- Bauer, M., et al., (2010): *Green Building; Guidebook for Sustainable Architecture*. Springer Verlag, Berlin, Heidelberg.
- Koprivec, L., (2009): *The Influence of Contemporary Materials and Technologies on the Building Envelope*. University of Ljubljana, Faculty of architecture, Ljubljana.
- Pfammatter, U., (2008): *Building the future, Building Technology and Cultural History from the Industrial Revolution until Today*. Prestel, Munich, Berlin, London, New York.
- Zbašnik-Senegačnik, M., Koprivec, L., (2009): *Biomimetics in the architecture of tomorrow*. AR, Architecture, research, University of Ljubljana, Faculty of architecture, Ljubljana.
- Zbašnik-Senegačnik, M., Koprivec, L., (2011): *Technological innovations of conventional materials on contemporary facade envelopes*. University of Ljubljana, Faculty of architecture, AR, Architecture, research, Ljubljana.
- Zbašnik-Senegačnik, M., Koprivec, L., Kresal, J., (2011): *Contemporary building skin: architecture-based survey of techniques and building technologies*. *Prostor: znanstveni časopis za arhitekturo i urbanizam*, Arhitektonski fakultet Sveučilišta, Zagreb.
- Trimo, d.d., *Engineering and production of pre-fabricated buildings*, Prijateljeva cesta 12, 8210 Trebnje, Slovenia
- [http://ec.europa.eu/information/sb/eeb\\_roadmap.pdf](http://ec.europa.eu/information/sb/eeb_roadmap.pdf), 2012
- <http://lgbegen.files.wordpress.com/2010/11/29mulberry-final-presentation.pdf>, 2012
- [http://smartgeometry.org/index.php?option=com\\_content&view=article&id=154](http://smartgeometry.org/index.php?option=com_content&view=article&id=154), 2012

<http://www.cnt-ltd.co.uk/nano/nanomaterials-in-architecture>, 2012

<http://www.dezeen.com/2008/05/07/greenpix-media-wall-by-simone-giostra-partners>, 2012

<http://www.domusweb.it/en/architecture/zollverein-school>, 2012

**Prof. Dr.  
Dragoslav Šumarac,  
Assist. Prof. Dr.  
Maja Todorović,  
Serbia**

**The Way to Energy Efficient  
Buildings and the Savings  
Potential in the Republic of Serbia**

Serbian Chamber of Engineers

E-mail: [sumi@EUnet.rs](mailto:sumi@EUnet.rs) / [mtodorovic@mas.bg.ac.rs](mailto:mtodorovic@mas.bg.ac.rs)



**ABSTRACT**

The paper presents an overview of the legislative framework of the energy certification of buildings in the Republic of Serbia. It gives a short description of the methodology of calculation of energy efficiency indicators for buildings, the layout of the building energy certificate, and the set of energy retrofit measures summary to improve the current situation. The energy savings potential is given for several categories of buildings, with particular reference to residential sector.

## INTRODUCTION

In developed countries, the global contribution to the energy consumption of buildings, both residential and commercial, is between 20% and 40%. During the last two decades primary energy input has grown by 49% and CO<sub>2</sub> emissions by 43%. Current predictions indicate that this growing trend will continue [1]. On the other hand it has been shown that conventional energy efficiency technologies, such as thermal insulation, low-emissivity windows, window overhangs, and day lighting controls can be used to decrease energy use in the new commercial buildings by 20-30% on average, and up to 40% for some building types and locations [2]. In this paper energy efficiency of residential buildings in Serbia will be presented. Previous results can be found in [3]. The average energy consumption in residential buildings in Serbia is over 150 kWh/m<sup>2</sup> per year, while in developed European countries it is about 50 kWh/m<sup>2</sup> per year.

Due to the rational use of energy, the European Union adopted the Directive 2002/91/EC as well as the recast 2010/31/EU. In Serbia, the Directive was implemented through the Law on Planning and Construction (Official Gazette RS 72/2009). Improving energy efficiency in buildings is a key task on the road to sustainable and secure energy supply and environmental protection. Mentioned strategies to reduce energy consumption in buildings, included in the Directive 2010/31/EU, demand from all member states, and states Parties to the Agreement with the Energy Community, to adjust the legislative framework, with national specificities, to introduce a systematic approach in the way of rational energy use in buildings. Basic elements of the Directive is a unique methodology for calculating the energy efficiency indicators to determine the energy rating in the process of building energy certification, energy audits of buildings and regular inspection of heating and air conditioning systems in buildings.

Pursuant to Article 201 of the Law on Planning and Construction of Serbia (Official Gazette no. 72/09, 81/09 and 24/11), Regulations were made, which prescribe rules to improve energy efficiency in buildings. Regulations on energy efficiency in buildings close prescribe the energy performance by introducing the method of the buildings' thermal properties calculation and energy requirements for new and existing buildings. Regulation on the conditions, content and manner of issuing energy performance certificates of buildings specifies the process of energy certification of buildings, manner and content of energy certificates and energy classes for both residential and non-residential buildings, new and existing.

## CALCULATION METHODOLOGY OF THE INDICATORS

According to Article 5 of the Regulation on energy efficiency in buildings, energy efficiency is met if the minimal comfort conditions are provided together with energy consumption per square meter, which does not exceed the limit. In this regard, the new requirements has been set, related to the thermal protection of buildings, through the limitation of maximum coefficients of heat transfer in building elements within the thermal envelope of the building [4].

Categorization of buildings is also defined in this Regulation, in accordance with the Directive on energy performance of buildings, so there are two categories of residential buildings (single-family houses and buildings with two or more apartments) and six categories of non-residential buildings: administrative and commercial buildings, facilities for education, health, tourism, sports, retail and mixed-use buildings. Buildings must be designed not to exceed the allowed annual energy consumption prescribed specifically for the new building, as well as for existing buildings after renovation, reconstruction or energy rehabilitation. An indicator that determines the energy class of the building in the transitional period is a specific annual energy for heating, while after the adoption of national software for calculation, total primary energy is to be calculated, as an indicator that provides specific annual primary energy.

## AN EXAMPLE OF EE EVALUATION FOR NEW BUILDING

An example of Energy Efficiency Evaluation is made for residential-commercial building in the Cvijiceva street in Belgrade with the net floor area of 1364m<sup>2</sup> (Figure 1). Location of the building is in down town area of Belgrade at the corner of Cvijiceva and Jase Prodanovica street. It represents a corner building with three free facades with medium exposure to dominant Belgrade winds: east and north wind.



Figure 1. 3D view of facades

Proračun	$Q_{H,nd,rel}$ [%]	$Q_{H,nd}$ [kWh/(m <sup>2</sup> a)]
		56
A+	≤ 15	
A	≤ 25	
B	≤ 50	
C	≤ 100	← C
D	≤ 150	
E	≤ 200	
F	≤ 250	
G	> 250	

Figure 2. Energy class of building

Data of energy class is obtained based on Regulation on conditions, content and the way of issuing certificate of energy performances of buildings [5], based on the class of building. It is represented graphically, as is shown in Figure 2.

## SAVINGS POTENTIAL BY IMPLEMENTATION OF COST-EFFECTIVE MEASURES

The energy savings potential is given in Figure 3 for several categories of buildings, with particular reference to residential sector, since the residential buildings take the biggest part of building stock in Serbia. Potential savings are obtained for cost-optimal set of energy retrofit measures [6].

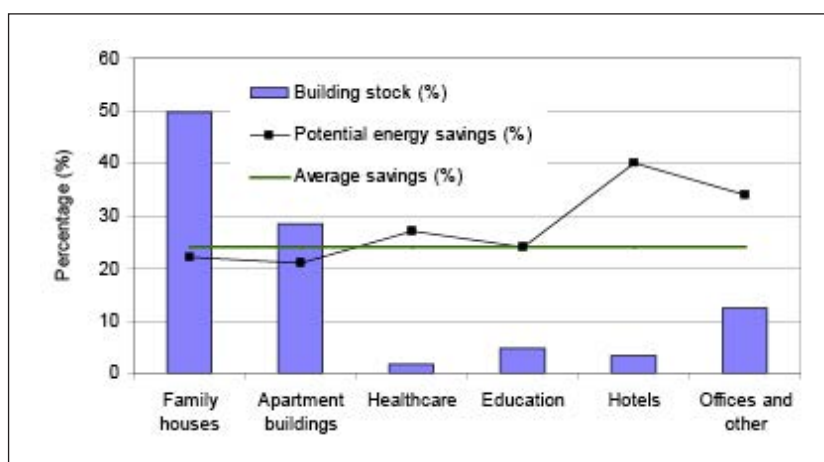

Figure 3. Percentage of Building Stock per category and potential energy savings

## ROLE OF SERBIAN CHAMBER OF ENGINEERS IN THE EE PROGRAM IN SERBIA

Serbian Chamber of Engineers is appointed by Ministry of spatial planning, mining and environmental protection to issue licenses for individuals. The License number for Chartered engineer for energy efficiency is 381. The Chartered engineer (an Architect, Civil Engineer, Mechanical and Electrical engineer) for EE is responsible for energy audits, Elaborates of EE and Energy passport of building. Minimum four years of experience is required. Before passing professional exam an engineer should complete Training program of EE, organized by Serbian Chamber of Engineers. For administrative activities for Professional exam in all sectors as well as in the sector of EE Serbian Chamber of Engineers is responsible too. It should be noticed that in June 2012, 350 engineers applied for the Training course. Currently, they are in the procedure to pass Professional exam for EE of buildings.

## CONCLUSIONS

Demands incorporated in Regulations in Serbia, in the sector of energy efficiency of buildings, will provide significant reduction of energy needed for this sector. Conditions of thermal insulation and minimal technical requirements for technical systems which consume energy in buildings are established in such a way that provide optimal economic level during design of new and reconstruction and recovery of existing buildings. The referent energy class of building is class "C". Methodology of indicators calculation are adopted from European standards which support implementation of EPBD 2010/31/EU.

## LITERATURE

- [1] Perez-Lombard, L., Ortiz, J. and Pout, C.: A review on buildings energy consumption information, *Energy and Buildings*, 40, pp. 394-398, 2008.
- [2] Kneifel, J.: Life-cycle carbon and cost analysis of energy efficiency measures in new commercial buildings, *Energy and Buildings*, 42, pp. 333-340, 2010.
- [3] Šumarac D., Todorović M., Đurović-Petrović M., Trišović N. (2010): Energy Efficiency of Residential Buildings in Serbia, *Thermal Science*, Vol. 14, Suppl. pp S97-S113.
- [4] Official gazette of RS No. 61/2011: Regulation on energy efficiency of buildings.
- [5] Official gazette of RS No. 61/2011: Regulation on conditions, content and the way of issuing certificate of energy performances of buildings.
- [6] ENSI (2012): Study on Energy Efficiency in Buildings in the Contracting Parties of the Energy Community, available on [http://www.energy-community.org/portal/page/portal/ENC\\_HOME/CALENDAR/Other\\_Meetings/2012/22\\_2](http://www.energy-community.org/portal/page/portal/ENC_HOME/CALENDAR/Other_Meetings/2012/22_2)



# Friderik Knez, Katja Slanc, Slovenia



353

FRIDERIK KNEZ

## Experience in Ecobalancing of Buildings in Slovenia

Slovenian National Building and Civil Engineering Institute

E-mail: [friderik.knez@zag.si](mailto:friderik.knez@zag.si)

### ABSTRACT

In buildings until recently there were many speculations in Slovenia about the ration between the CO<sub>2</sub> emissions, produced in the use phase of a building's life cycle compared to emissions connected to production of construction materials used. By establishing a common standard, EN 15978 a framework for intercomparable calculations was set. Usability of the standard in Slovenia was investigated with an ecobalance of an actual building. The results are expressed in impact categories. In the results different phases of building's life cycle are compared and evaluated. Special attention is given to the ratio of the CO<sub>2</sub> produced in the use phase and the CO<sub>2</sub> produced in construction materials production. In some cases later was found to be higher.

## INTRODUCTION

Roughly 40% of CO<sub>2</sub> emissions arise from buildings. This puts buildings in primary focus when trying to lower the CO<sub>2</sub> emissions. In near past most attention has been given to increase energy efficiency in buildings, combined with increased use of renewable energy sources and through that achieving reduction of CO<sub>2</sub> emissions. Although the efforts for energy efficient building stock is nowhere finished at least for the new build emissions from energy use of buildings will be in effect mandatorily annulled. This imposes question what are the emissions built in building fabric and whether urgently additional focus on that issue has to be given to construction activities.

## STATE OF THE ART

The question of CO<sub>2</sub> emissions caused by producing construction products is not new in the EU nor is it unaddressed. In contrary, quite some analyses have been done in the EU yielding that focusing only on energy performance of buildings may seriously diminish overall expected effect. With recent adoption of the EN 15978 there is also a tool available for calculation.

Coinciding with green public procurement Slovenian legislation analyses have to be implemented as soon as possible. Currently in the Regulation on green public procurement wood is given special position because of an assumption it is one of most environmentally friendly materials that are used construction. However building is not built only of wood. Therefor question on the difference between massive and light weight build is raised.

Finally attempts for Slovene green building certification are strongly present, lately. Such a certification will not rely on energy only but appropriate emphasis will be given to use of materials as well. This leads to additional drive for starting up a scheme of ecobalancing in buildings.

## MOTIVATION

In Slovenia so far we have quite limited experience in calculating eco balance of buildings. In fact only few partial results are published. Therefor the effort, presented in this article aims to four goals:

- 1) to gain experience in calculation and to deal with numerous dilemmas of ecobalancing such as cut-off, wood, end-of-life scenario etc., but especially focused on influence of selection of construction materials
- 2) to start building basis for benchmarking. This point is essential for progress in the green public procurement regulation since currently there is unfavorable mix of criteria present
- 3) to assess viability of such calculations including price.
- 4) to test available tools to recognize completeness and lack of LCA data on construction materials. The data used is used from the same source to maximum possible extent. Although this does not improve accuracy in absolute numbers one might suggest it helps in relative comparisons of solutions.

## THE MODELED CASE

Primary interest in this work was to compare two executions of a single family house: built in light weight timber frame construction and built in massive, brick construction. The house is based on architectural blueprints for wooden timber frame house. Net living area of the house is 149,77 m<sup>2</sup>. The envelope surface to volume ratio is 1,13 m<sup>-1</sup>. It is a two floor house. The layout is presented in figure 1. The ground floor is L shaped. Adjacent to the house there is a garage which is not part of the evaluation. The first floor lays above ground floor, along the house's major axis. The house has pitched roof and has no celery.

Estimated service life time of the house is 60 years. The house is class A according to the energy certification (passive house energy use); energy use is limited to 15 kWh/m<sup>2</sup> for heating and 45 kWh/m<sup>2</sup> primary energy yearly.

For assessment of massive house same layout is analyzed, however timber frame structures are replaced with brick structure and wooden flooring is replaced with concrete slabs. Since aim of the study is only comparison it is believed that although refined massive house modeling would change results to a certain extent, major trends would remain the same.

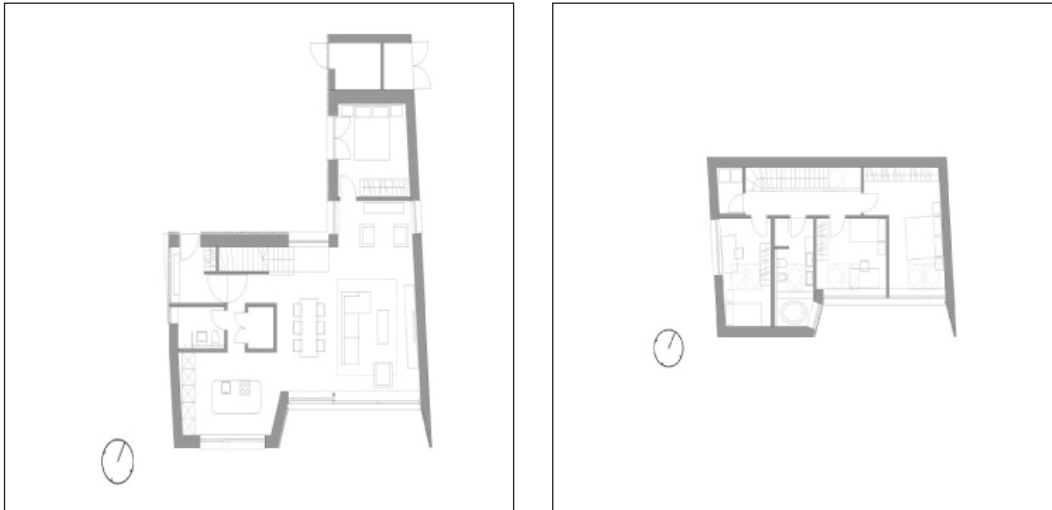

Figure 1: plan of ground floor (left) and 1<sup>st</sup> floor (right) of modeled house.

Calculations are done following EN 15978, but due to the scope of the study limited to construction materials selection. Modeling was done using GaBi 4 software. Most significant materials (materials influencing the difference) and their data is given in table 1. The data is taken from commercial databases.

per kg of:	ADP fos	ADP elem	AP	EP	GWP	ODP	POCP
	MJ	kg Sb-eq.	kg SO <sub>2</sub> -eq.	kg Phosphate-eq.	kg CO <sub>2</sub> -eq.	kg R11-eq.	kg Ethene-eq.
<b>wood</b>	7,4E+00	2,2E-08	1,8E-03	2,0E-04	5,7E-01	5,7E-08	1,4E-04
<b>brick</b>	1,3E+00	6,4E-09	2,0E-04	2,8E-05	2,3E-01	2,2E-09	2,0E-05
<b>mineral wool</b>	1,2E+01	2,1E-07	6,5E-03	7,5E-04	1,2E+00	4,5E-08	4,7E-04
<b>celulose fiber</b>	2,3E+00	1,3E-04	8,3E-04	1,4E-04	4,1E-01	1,8E-08	6,9E-05
<b>EPS</b>	7,5E+01	2,8E-07	5,4E-03	5,6E-04	2,2E+00	9,1E-08	8,3E-04

Table 1: impact indicators of different materials, used.

Individual structures were analyzed. Most difference is in external wall structures. The comparison is based on same U value of external envelope in both cases, providing comparable building performance.

Other contributions, such as transport may in general be quite high; however they are excluded from the analyses because the projects are hypothetical. Second reason is belief that the difference between both cases will not be significant because supposed location is Slovenia which rather limits length of transport paths.

## RESULTS

Results are expressed in CML2001 indicators: GWP, ODP, POCP, AP, EP, ADP fossil and ADP element. The results are given in table 2.

	GWP		ODP		POCP		AP	
	kg CO <sub>2</sub> -Equiv.		kg R11-Equiv.		kg Ethene-Equiv.		kg SO <sub>2</sub> -Equiv.	
	wood	brick	wood	brick	wood	brick	wood	brick
<b>Total</b>	<b>47902</b>	<b>63807</b>	<b>2,44E-03</b>	<b>2,10E-03</b>	<b>17,55</b>	<b>17,25</b>	<b>111,26</b>	<b>118,09</b>
attic	290	290	1,79E-05	1,79E-05	0,12	0,12	0,77	0,77
inner walls	4380	10793	2,48E-04	1,94E-04	0,70	1,25	7,09	11,95
roof	6244	6244	4,32E-04	4,32E-04	1,61	1,61	14,14	14,14
external wall	8795	18203	6,05E-04	3,77E-04	3,63	3,88	20,90	26,11
cieling	5153	7758	2,37E-04	1,93E-04	1,53	1,52	10,32	13,63
ground slab	12929	12929	4,24E-04	4,24E-04	4,45	4,45	25,22	25,22
installations	2203	2203	1,37E-04	1,37E-04	1,26	1,26	5,72	5,72
windows	5154	5154	3,29E-04	3,29E-04	3,04	3,04	19,95	19,95
metal elements	2754	233	1,36E-05	8,59E-07	1,20	0,11	7,15	0,59

	ADP fos		ADP elem		EP	
	MJ		kg Sb-Equiv.		kg Phosphate-Equiv.	
	wood	brick	wood	brick	wood	brick
<b>Total</b>	<b>554327</b>	<b>599940</b>	<b>1,45315</b>	<b>0,59030</b>	<b>14,312</b>	<b>16,780</b>
attic	3492	3492	4,60E-04	4,60E-04	0,094	0,094
inner walls	53449	60052	2,46E-01	1,46E-02	1,117	2,260
roof	65707	65707	4,83E-01	4,83E-01	2,061	2,061
external wall	98584	173265	6,25E-01	2,61E-02	2,635	3,780
cieling	52480	48760	4,42E-02	1,13E-02	1,459	2,304
ground slab	143989	143989	1,65E-02	1,65E-02	3,784	3,784
installations	55965	55965	1,86E-03	1,86E-03	0,695	0,695
windows	46357	46357	3,64E-02	3,64E-02	1,760	1,760
metal elements	34304	2354	3,43E-04	6,60E-05	0,707	0,042

Table 2: results of calculations.

Comparison of individual selected indicators is given in figure 2.

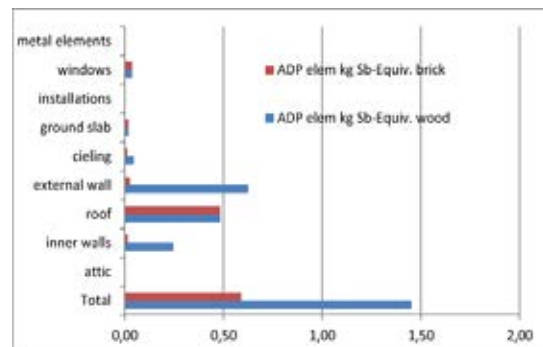
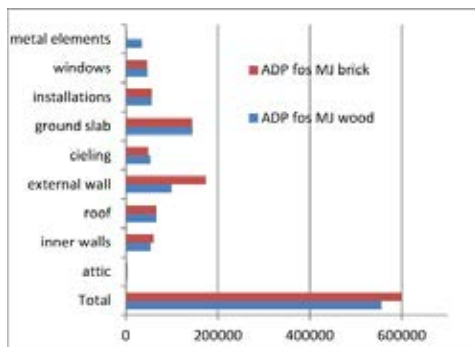
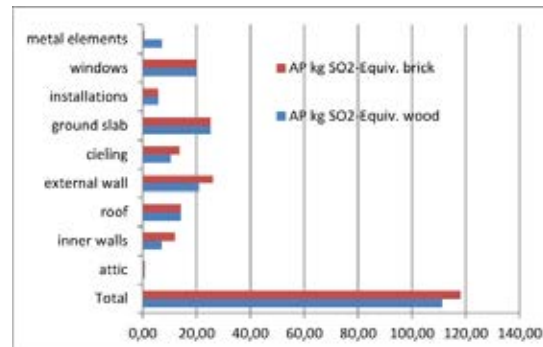
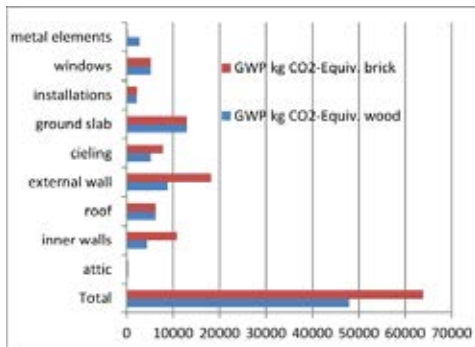

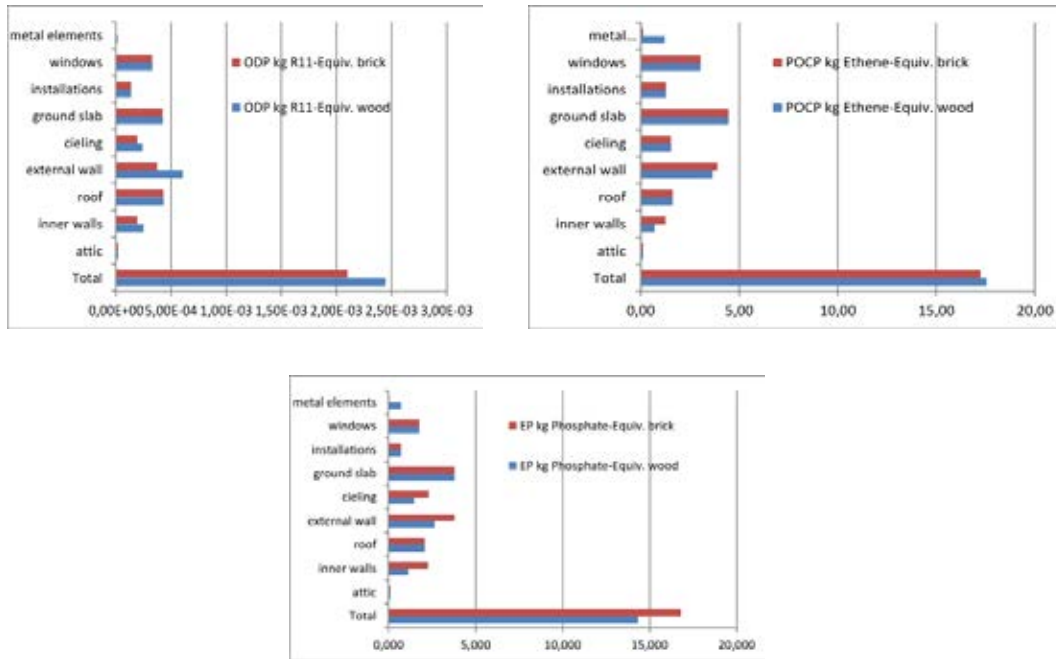

Figure 2: different indicators for comparison between the cases (indicators shown on graphs).

Although use-phase was not modeled in the work some major points can still be analyzed. Primarily comparison of CO<sub>2</sub> emissions is interesting. Given the expected energy use and size and taking into account popular heat source – ground to water electrically driven heat pump with overall estimated COP 2,5 CO<sub>2</sub> emissions from energy use can be assessed. Conversion factor kWh to kg CO<sub>2</sub> for electricity is taken from Slovene 2008 legislation and is 0,53 kg CO<sub>2</sub> / kWh. Assuming 15 kWh/m<sup>2</sup>a use of energy for heating and building size 149,77 m<sup>2</sup>, energy used for heating is 2247 kWh/a for which 899 kWh of electricity is used. Result is converted to 476 kg/CO<sub>2</sub>. Given the reference service life 60 years this amounts in 28576 kg CO<sub>2</sub> in life time. Same calculation for primary energy demand, assuming electricity yields 85728 kg CO<sub>2</sub>. Comparison of the CO<sub>2</sub> used in production phase of construction materials is given in figure 3.

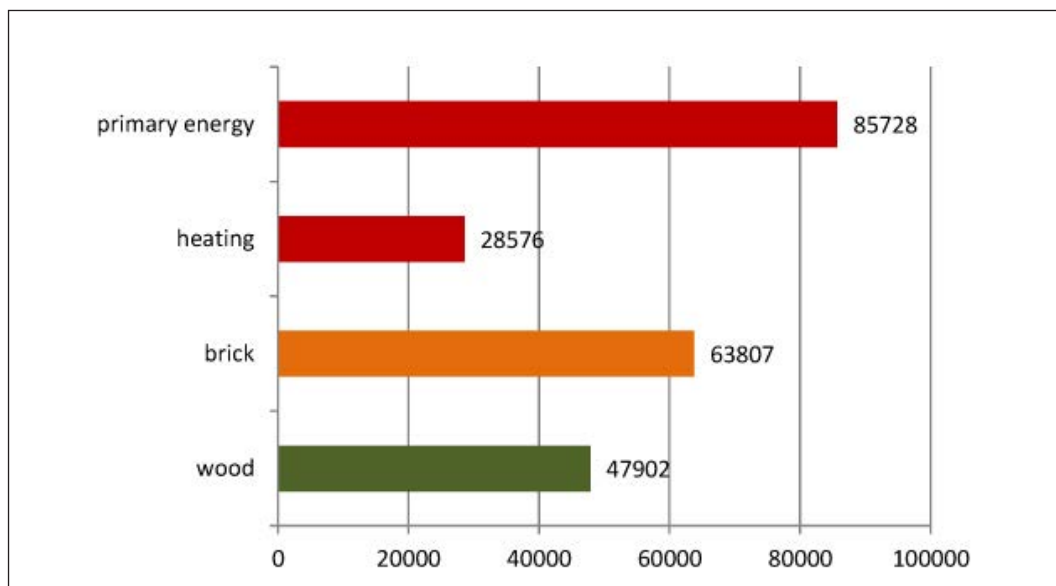

Figure 3: comparison of CO<sub>2</sub>-eq. emissions (60 years).

## DISCUSSION

There are several differences found. The big difference in elementary abiotic resource depletion in external wall arises from use of cellulose insulation.

Second interesting comparison is comparison of GWP. Important difference is seen, timber frame house having smaller GWP as brick house, as expected. Acidification (AP) and to certain extent eutrophication (EP) is comparable between the two builds. Timber frame house has slightly higher POCP and ODP.

Most important result, however, is comparison of CO<sub>2</sub> emissions (GWP) in materials in comparison to CO<sub>2</sub> released in the use phase. Figures are quite comparable within the order of magnitude, proving, that selection of materials has to be done carefully in order to achieve true low emission buildings.

Exchange of components (windows, roof, façade) is also important, although not calculated here. These components have normally life span significantly shorter than is life span of building as such. In most cases repairable components are repaired at least once in 60 years. Similar indications are found in different sources. If we consider this information additionally the importance of in-built materials is even greater, far exceeding CO<sub>2</sub> emissions caused by heating.

## CONCLUSIONS

Although incomplete the exercise has shown that it is possible to assess difference between different builds of houses. Difference between timber frame build and brick build is significant, yet lower than it was expected. Main reason is the fact, that the difference tackles only part of both houses.

It is also highly recommended to include the method into green public procurement regulation as soon as possible. This will provide proper benchmarking. This is especially important in order to build true environmentally friendly buildings instead of energy efficient buildings.

## ACKNOWLEDGEMENT

The research leading to these results has received funding from Ministry of education, culture, science and sport (Competence center TIGR) which is highly appreciated. The information given in this publication does not necessarily represent the view of the Ministry.

## REFERENCES

- Alexander Passer, Helmuth Kreiner and Peter Maydl, *Assessment of the environmental performance of buildings: A critical evaluation of the influence of technical building equipment on residential buildings*, The International Journal of Life Cycle Assessment, Online First™, 8 May 2012, Springer
- Asa Jonson, *Including the use phase in LCA of floor coverings*, Int.J.LCA 4 (6), 1999, Springer
- Divya Pandey, Madhoolika Agrawal, Jai Shakner Pandey, *Carbon footprint: current methods of estimation*, Environ Monit Assess, 2011, Springer
- Leif Gustafsson, Kim Pingoud, Roger Sathre, *Carbon dioxide balance of wood substitution: comparing concrete and wood framed buildings*, Mitigation and adaptation strategies for global change (2006) 11, Springer

# Mladenka Dabac, Croatia



359

## Renewable Energy Sources / Res Way Towards Green Tourism

Dabacarhitects d.o.o.

E-mail: [dabacarchitects@web.de](mailto:dabacarchitects@web.de)

MLADENKA DABAC

### ABSTRACT

Lightweight metal skeletal constructions (acronym LMSK EEE+OIE) are based on a software which has been used in Germany since 2003. It is a self-supporting, dry, modular, multilayered and inovative building construction. The key characteristic of the LMSK EEE+OIE system is energy efficiency (EE) and environmental compatibility (E), which means that the LMSK projects are within sustainable architecture, that is "green building" architecture, with the use of renewable energy sources (OIE). In five promotional LMSK projects carried out between 2005 and the end of 2008 (a reconstruction of Zagreb Seminary and four pharmacy halls in Sv. Nedelja and Vukovar), complex solutions were archived. In projects carried out since 2009, OIE features have been implemented on the LMSK system, particularly photovoltaics (for instance, solar fields in Čazma). The key features of the systems are EEE and the benefits of using renewable energy sources; further advantages are gained through a combination of structural systems generated by a specific project.

The profession and all other members of the society and economy have to answer the challenges of the new millennium: natural disasters, global warming, explicitness and restraints of classical energy-generating products, with new practices. The key goal of the European politics EU 20-20-20 is zero-energy buildings. Buildings are the major pollutants (41%) and, therefore, by 2020 at the latest, they should produce by green practices as much energy as they spend i.e. be energy self-sufficient, or in other words, be power plants. It is possible to achieve this goal by combining energetic efficiency /EE, environmental suitability E and implementing renewable energy sources / RES, depending on the location. This can be carried out by interdisciplinary design which assumes a number of interconnected knowledge and professions united in a complete result. Unlike present designs of complex projects, the changed, new requirements demand further interconnections of specialists, absolutely varied knowledge and professions and their structuring into special new groups within projects. We have turned into the society of specialists; our results have to be sustainable on all levels, for example: economic, sociologic, constructional etc.

One of the most complex examples of interdisciplinary design was a carried out project by my architecture studio in Karlsruhe: the architecture of light for the largest European railroad terminal in Leipzig. HPP architects from Düsseldorf carried out the project for the station. Together with VDE/ The Association of German Electrical Engineers /Bonn I carried out, in special segment, the architecture of light /Lichtarchitektur on the entire station ceiling, much needed for the complete result.

Since 2003 onwards I have started with my authoring +green projects between Germany and Croatia whose focuses are: sustainable development, sustainable architecture, green tourism and green innovation, putting together an international green team, +Green group.

Between the architecture of lights on the terminal in Leipzig and the most recent +green Hotel Sv. Križ (St. Cross) \*\*\*\* in 2011 there are no differences in my general designing approach.

Beside the complexity of designing challenges, one of the key features of such interdisciplinary design is a need for cross-bordering in such projects. Even though the location generates the majority of conditions of such interdisciplinary work, the special significance is cross-bordering, or European Union, project context. Such EU context is, for example: the coordination of united EU norms and regulations, including experts in various destinations and educations, all by wise cooperation and crucial engagement of local designers.

By the accession into the European Union, Croatia will, in the framework of completely new challenges on all levels of the society and economy, agree on its own approach towards interdisciplinary design, and furthermore, develop it in its own sense due to the fact that we have excellent designers. Newly opened market of 500 million Europeans will also define new requirements on all areas, including interdisciplinary design. The spotlight will be on the responsibility of architecture / construction and their designers, on all levels: from social, environmental to economic responsibility etc.

The key features of my authoring +green project are the advantages and savings for the user, achieved exactly through interdisciplinary design.

In 2008 I developed +green hotel project and in 2009 I included Croatian Chamber of Economy / HKG in it. Like Michelin stars, this hotel should receive a +green star. The owners of the hotel Sv. Križ (St. Cross) \*\*\*\* wanted to upgrade the classification of their hotel through successful hotel management of health tourism from a three star to a four star hotel.

We offered them and we carried out a complete solution with interdisciplinary +green design. With a number of green components, like solar collectors, other designer measures and the synergy with an excellent management we created a complete result of a year-round tourism. While neighboring hotels are open on average three months, hotel Sv. Križ (St. Cross) \*\*\*\* is always full with rational and economically distributed costs.



# Barry Lynham, France



361

## Delivering Low Energy Buildings that Work in Reality

Knauf Insulation

E-mail: [barry.lynham@knaufinsulation.com](mailto:barry.lynham@knaufinsulation.com)

BARRY LYNHAM

### ABSTRACT

Speaker would cover the drive towards low energy buildings, the gap between real thermal performance and actual performance, the main issues that need to be tackled to close the gap as well as touching on finance and new business models that are needed to ensure that delivery actually happens.

## DELIVERING LOW ENERGY BUILDINGS THAT WORK IN REALITY

**As reducing energy from the built environment becomes a priority and governing bodies enact regulations to make this happen, it becomes critical to ensure that the actions taken lead to real energy and carbon savings. Unfortunately, recent studies indicate that large gaps exist between the theoretical and actual thermal performance of buildings. And, due to a lack of coordinated research to-date, a “knowledge gap” exists that is making this worse.**

**To fill this gap, leaders from all sectors of the building industry must work together to understand why buildings are not always performing as well as expected and must take up the challenge of delivering solutions that ensure low energy buildings work in reality, every time.**

### 1. CONTEXT

Across the globe, modern society finds itself caught in the tightening squeeze of its growing reliance on energy. Even as worldwide demand for energy increases, the known reserves of its primary source—fossil fuels—diminish with each passing day. And the very use of such resources contributes to emissions that warm the planet, threatening the immediate health of local populations and the sustainability of global society itself.

Studies conducted in recent years have highlighted that the built environment is a major user of energy. In the EU, for example, buildings account for approximately 40% of the total energy use and its associated emissions – more than all forms of transportation combined. And 70% of that energy is used to heat and cool the buildings in which we live.

To address the matter proactively, governments are beginning to adopt “near-zero” energy standards for buildings. Under the re-casted European Energy Performance of Buildings Directive (EPBD), for example, by the end of 2020 all new buildings will need to be designed to nearly-zero energy building levels.

Ensuring that new buildings are near-zero energy will unfortunately not deliver, by itself, a low-energy built environment. Rather, with more than half of the existing global building stock still expected to be standing in 2050, retrofitting existing buildings must also be a priority for action if we are serious about reducing energy from the built environment. And if ensuring that design matches reality in new build is a challenge, delivering this after a retrofit will be even more difficult.

Regardless of whether we are building new or renovating old it is essential that the energy efficient technologies used in buildings deliver in reality. It is essential that we understand why the gap currently exists and then develop systems and solutions that ensure we close this gap. This is our challenge.

### 2. CHALLENGES

#### **Nature does not honour good intentions.**

The current regulations and standards that govern thermal performance in buildings are mostly based on models of how buildings perform and laboratory testing of products. The models presume that at a design level we know fairly accurately how buildings actually perform; which is not always the case. The laboratory testing, whilst providing a good view on the intrinsic properties of products, was not designed or meant to take into account issues such as the impact of poor installation. Taken together, this means that sometimes the real thermal performance of a building can be significantly worse than expected. Unfortunately what nature needs is less carbon emissions and what people want is less costs related to heating and cooling their homes. Good intentions are therefore not good enough; we need to move to real performance.

The first step toward real performance is to recognise, identify, and address the gaps that exist between what is known and what needs to be known and this is why at Knauf Insulation we have launched our building physics programme, so that together with leading academics in the field, we can take our collective responsibility to ensure that we move rapidly towards buildings that really perform.

## 1. Factors Affecting Building Efficiency and Performance

The energy performance of any building depends on an interactive system consisting of three main elements (Figure 1)—fabric, services, and occupant behaviour.

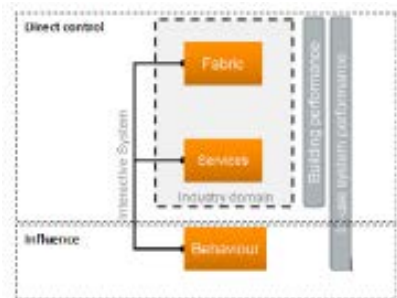

Figure 1: Factors affecting building efficiency and performance

The *fabric* consists of the thermal envelope that contains the internal environment. *Services* include operations that heat, cool, and ventilate the environment (e.g. HVAC systems). And the *behaviour* component reflects the actions of the building user to maintain comfort and health through the use of temperature control, ventilation, and lighting.

Of these three factors, two are the primary responsibility of industry to deliver effectively - fabric and services. And of these two, the building fabric is most critical to the successful implementation of measures to reduce energy consumption. A building that leaks heat to its environment can substantially negate the benefits of the most efficient HVAC system even if it is operated by a smart, informed, responsible user. For acceptable energy performance, the thermal envelope of a building must be sound.

## 2. Current Performance and Knowledge Gaps

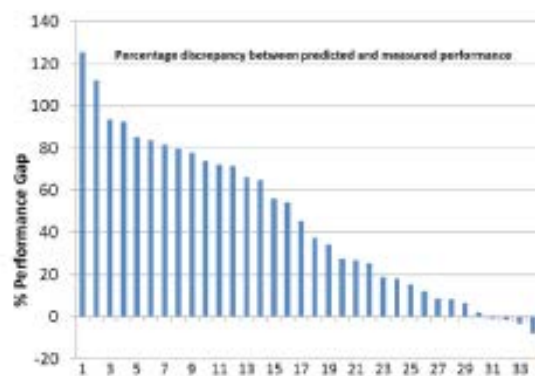

Figure 2: Building Envelope Performance gap (%) for dwellings in UK study

To solve this problem, one must first recognise the problem and assess its true size and scope. In the case of building thermal performance, the first step toward developing a useful understanding is to identify and recognise the gaps that currently exist between theoretical and real-world thermal performance of buildings.

To date, the total body of work in this area remains fairly limited. But the studies that do exist, paint a concerning picture. Not only do some buildings perform significantly worse than expected, for example as much as 120% worse in a recent UK study, but the variation in performance is also significant; in the same UK study some buildings performed better than expected.

**What to do:** The answer is two-fold. On one hand there is simply a need for more studies and more information, so that we can develop a greater understanding of the nature and size of the problem. This is a job for both academia and industry; this is why Knauf Insulation has teamed up with leading experts to support this work. On the other hand we need to understand what is causing these differences and what can be done to both reduce the gap in real performance as well as the variability. Again working with academics and specialists, Knauf Insulation is not only supporting the effort to identify the causes but to also develop systems and solutions that can support the building chain with their responsibility to deliver buildings that deliver real performance.

### 3. Possible Sources of the Performance Gaps

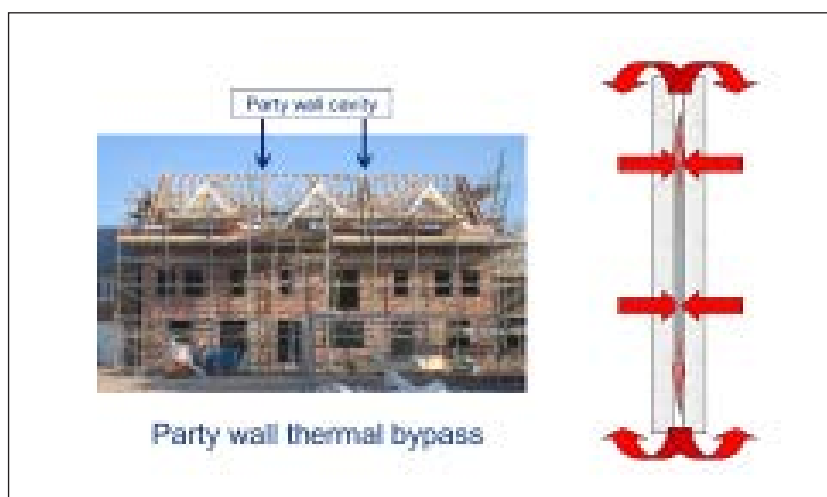

Figure 3: In the picture of the house you can see the 'party' wall gap that was filled.

The gap between theoretical and real-world energy performance for any building can result from a multitude of factors, including incorrect theoretical models, poor building design, and/or poor construction and installation practices. The real-world performance of the thermal envelope depends strongly, for example, on the characteristics of the building insulation—not only how the materials are designed and manufactured but how they are used in the design of the building and implemented in its actual construction.

An example of incorrect theoretical models can be demonstrated by a study carried out in a group of row houses (Figure 3). As is the norm in some countries, row houses are built with an air gap between each house; this design feature was developed to reduce noise transmission between the houses. Given that houses either side of the gap are heated to similar levels, models had presumed that there was no heat flow. The reality from real life testing was that the gap acted like a chimney, drawing heat up and out of the house, causing a major difference in real versus design thermal performance. However, once the gap was filled with mineral wool and properly sealed, the thermal performance issue was addressed without compromising acoustical performance (see figure x).

This study demonstrates the positive impact of correctly installed insulation on the real-world performance of a building's thermal envelope. As this was only one investigation, it does not by itself provide a full understanding of the issues that affect real-world performance.

**What to do:** The development of a correct understanding and its application to real-world energy use, will require a concerted effort on the part of stakeholders from all corners of the building industry. Only a major effort from all such stakeholders can provide the knowledge base necessary to make informed decisions and take the necessary steps regarding the design, construction, and regulation of buildings that perform to expectations in the real world.

Within this overall approach, Knauf Insulation sees an important support role for companies such as ours. Given this, we have put in place an annual 'Reality Check' symposium where we bring together leading experts from industry and academia to discuss the challenges and how different actors will need to work to ensure real performance is delivered.

#### 4. Testing, Measurement and Standards

The development of an effective knowledge base for real-world building energy performance requires more than just data generation. It also requires testing and measurement protocols and standards that can be applied consistently across the industry regardless of building geography or environment. Only by developing repeatable and sensible protocols for gathering and analysing data can the industry hope to use the data to its fullest effect and to create models that can generate accurate and reasonable expectations of real-world performance for insulation products.

One test that may serve as model for the development of robust protocols is the "co-heating" test, in which the dwelling to be tested is homogeneously heated to an elevated interior temperature—for example, 25 °C. (Figure 4)

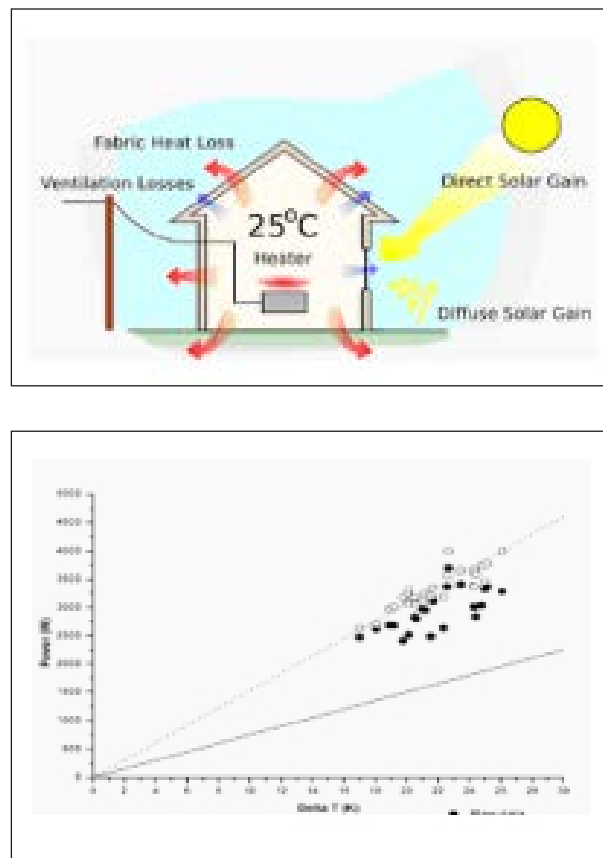

Figure 4: By measuring the amount of power required to maintain the elevated internal temperature and taking into account environmental factors such as wind speed, outdoor temperature, and solar radiation, it is possible to calculate an overall heat loss coefficient for the dwelling

**What to do:** As with current standards that provide a robust basis for comparing the thermal performance of insulation products, it's important to develop agreed and common standards for measuring the real thermal performance of the fabric of a building. The co-heating test could be the basis for such a standard and currently Knauf Insulation is a leading member of the European standards group that is in the process of developing real performance measurement standards.

### 3. RESPONSE

Beyond understanding the cause of the problems, there remain other major challenges to ensure that low energy buildings can be delivered that really perform. On one side, there is a need to offer the market systems and solutions that are robust and support the delivery of real performance – this is a challenge that falls squarely on the shoulders of companies such as Knauf Insulation. On the other, there is need to develop regulatory frameworks that ensure that the building chain is incentivised to deliver real thermal performance rather than to deliver the lowest up front cost option; here all actors in the building chain have a role in ensuring that this happens.

#### Systems and Solutions

Air tightness, reducing thermal bridging, avoiding installation errors, these are all things that taking a systems approach can help resolve. Therefore, as we move the low energy built environment and we strive to deliver real performance its incumbent on companies to deliver systems and solutions. At Knauf Insulation we have begun this process and are beginning to launch systems that help overcome specific challenges.

# Dr. Matjaž Žnidaršič, Slovenia



367

MATJAŽ ŽNIDARŠIČ

## A High-Tech Green Building

CBS institute d.o.o.

E-mail: [matjaz.znidarsic@cbs-institut.si](mailto:matjaz.znidarsic@cbs-institut.si)

### ABSTRACT

What is a green building? Is it green because of a green roof or a green façade envelope? Maybe.

What is a high tech building? Is it made of high tech materials with installed high tech technology products? Maybe.

The theme deals with completely new curtain wall system, Qbiss Air envisioned to be used for every type of skeleton building. We, Trimo d.d. and CBS institute d.o.o. developed an energy efficient curtain wall panel which consists of thin multi chamber gas filled insulation core covered with enamelled glass (outer plate) and reinforced gypsum board (inner plate) of maximum size 4000x1250mm. Qbiss Air panels are manufactured in a fully automated assembly line which probably comprises the longest robotised unit in Slovenia. The U value of the insulation core is 0.17 W/m<sup>2</sup>K, at thickness of 100 mm, and the U value of complete Qbiss Air system together with integrated all necessary load bearing profiles and gaskets is 0.25 W/m<sup>2</sup>K. Sound impedance is at least 46 dB in the basic version and can be pushed up to 60 dB. The Qbiss Air system together with windows is fully compatible to existing curtain wall systems and also offers many possibilities like integration of PV modulus, illuminations and in future natural light transmittance too.

The question is what is green and high tech in Qbiss Air system. We have high tech production line for curtain wall elements which fulfil highest living comfort with very low CO<sub>2</sub> footprint regarding the 96% recyclability of materials used.

We developed sustainable curtain walling system prepared to fulfil highest demands on curtain wall market.

## 1. HIGH TECH GREEN BUILDING

Energy efficiency is very important in European energy policies from many aspects:

- energy supply security,
- competitiveness of European companies,
- reduction of greenhouse gases.

The building sector use more than 40% of energy demand in Europe. One third of this demand can be attributed to non-residential buildings, such as offices, factories, schools, hospitals or hotels [1]. The largest potentials for energy savings can be done by improving heating and cooling systems of buildings as well as by optimising the building envelope. Most of the European countries are supporting private and public organisations to realise this substantial potential for energy savings also with legislation – i.e. PURES (Regulation for efficient energy consumption in buildings in Slovenia).

There are two main environmental assessment of buildings BREEAM (the Building Research Establishment Environmental Assessment Method) and LEED (Leadership in Energy and Environmental Design) [2]. There are many similar methods such as Greenstar in Australia and CASBEE in Japan but BREEAM and LEED are main methods in use. There are some differences between those two methods in the process of certification but at the end both methods are worldwide standard for best practice in sustainable building design, construction and operation defining a building's environmental performance.

We all hear terms green and/or sustainable and are asking ourselves what is green? What is sustainability? There are many definitions of what it means to be a sustainable or green but none of them are the definitive, final answer for all. Nevertheless the idea of green building means energy efficient, healthy buildings and it has been around for a long time. The basic idea of high tech green building which we think Qbiss Air system is has developed directly from market demand. It is obvious that the value of certified green buildings can be measured with positive gentrification effect and higher rents [2]. There are many ways to estimate green buildings but the main are [3]:

- energy efficiency including the use of renewal energy sources (wind, geothermal, solar),
- minimization of volatile organic compound,
- healthy indoor air environment with proper ventilation system,
- recyclability and low embodied energy in materials used for construction.

## 2. QBISS AIR CURTAIN WALL SYSTEM

Our answer to demanding market of energy efficient green buildings is a complete novelty in curtain wall systems - Qbiss Air [4]. Qbiss Air is a gas-filled panel curtain wall system. The basic idea was to produce insulation material which can offer best price performance ratio regarding thickness with as low as possible environmental effect. We found several attractive options amongst modern refrigerant gases (R32, R23), inert gases, CO<sub>2</sub> and others [5,6]. We chose CO<sub>2</sub> and argon to be used as an insulation gas mainly because of economical, ecological and engineering reasons. On the basis of experimental work we propose five gas partitions with 20 mm gaps for use with either argon or CO<sub>2</sub>. The gas chambers are separated with aluminium foils which together with insulation gas enable low U value (U=0.17 W/m<sup>2</sup>K at thickness of 100 mm) (Fig 1).

The Qbiss Air system fulfills highest living comfort demands with very low CO<sub>2</sub> footprint regarding the 96% recyclability of materials. Qbiss Air consists of (Fig 1):

- exterior skin is glass or high pressure laminate (HPL),
- high performance five chamber gas (CO<sub>2</sub>) filled insulation core,
- interior skin is fibre reinforced gypsum plate (prefabricated) and additional gypsum plate (on site),
- additional polymer profile with steel bar.



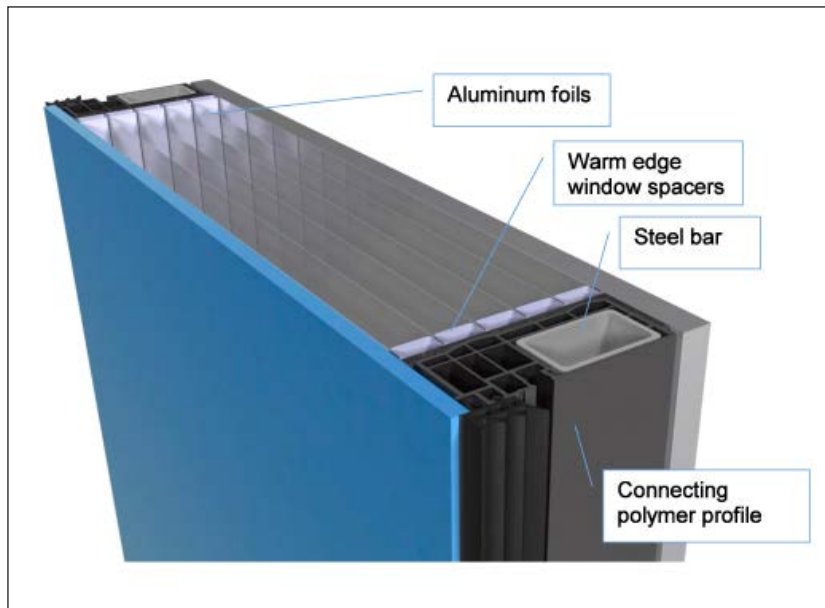

Fig 1: Gas-filled panel mechanical design

The stiffness of panels is improved with reinforced polymer profiles and galvanized steel bars (Fig 1). The polymer profiles made of extruded PA 6.6 GF40 are glued to outer plate (enamelled glass or HPL) and to inner plate (reinforced gypsum plate).

The basic technical data are:

- low thermal coefficient value ( $U_{\text{system}} = 0.25 \text{ W/m}^2\text{K}$ ,  $U_{\text{insulation core}} = 0.17 \text{ W/m}^2\text{K}$ ) at very thin curtain wall skin ( $d < 140 \text{ mm}$ ) to enable as much as possible living space,
- high sound reduction from  $R_w > 46 \text{ dB}$  up to  $60 \text{ dB}$ ,
- fire safety EI60 up to EI120 and more,
- water tightness of minimum  $900 \text{ Pa}$ ,
- high tech production of prefabricated elements with dimensions from  $500 \times 500 \text{ mm}$  to  $4000 \times 1250 \text{ mm}$  with increment of  $1 \text{ mm}$ .

Comparing with glass curtain wall we maximised living comfort and fire safety (Fig 2). Thermal and sound insulation and water permeability are more than 50% better performance compared to majority of glass curtain wall systems.

	<b>Qbiss Air Non-transparent glass facade system</b>	<b>Non-transparent glass facade (7.,5 cm MW)</b>	<b>Non-transparent glass facade (10 cm MW)</b>
U – value ( $\text{W/m}^2\text{K}$ ):	0.17 – insulation core; 0.25 – system	min 0.40 – insulation core; min 0.6 – system	min 0.33 – insulation core; min 0.5 – system
R <sub>w</sub> – sound insulation (dB):	≥46	30	30
Water permeability (Pa):	900	600	600
Fire resistance (min):	≥ EI60	EI30	EI30

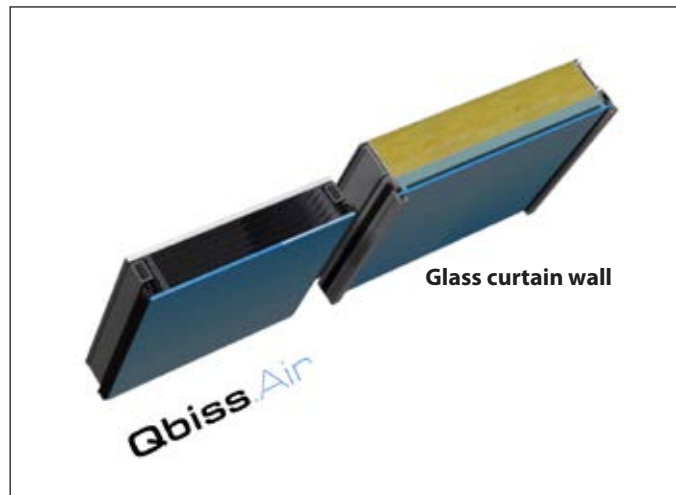

Fig 2: Qbiss Air curtain wall system

Minimised construction time is achieved with fast, clean and low risk build with light, prefabricated panels. Building can be brought into commission earlier and more quickly returns its investment (Fig 3).

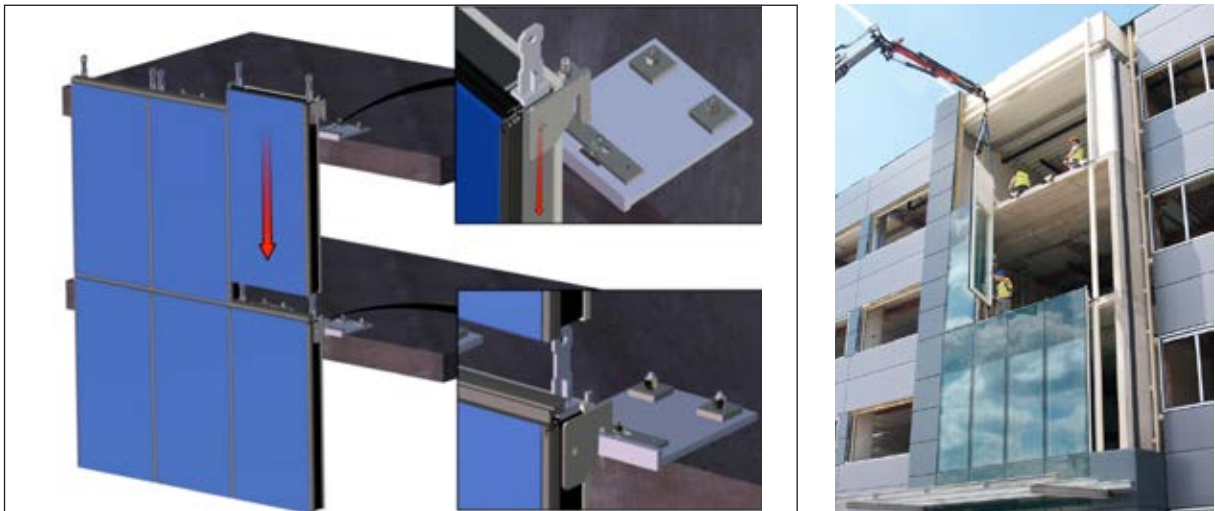

Fig 3: Installation of Qbiss Air elements

#### High tech Qbiss Air production line

To enable productivity Qbiss Air panels are manufactured in an automated assembly line (Fig 3):

- transporting of bended spacers with improved thermal characteristics,
- applying of glue on both sides of spacers,
- aluminium foil cutting and positioning,
- outer and inner plate preparation – cleaning and plasma treatment,
- assembly of elements.



Fig 3: Qbiss Air assembly line

After assembly of outer and inner plates together with 5 chambers core the gas filling process and polymer profiles installation take place. The complete production line needs only 5 workers.

### 3. QBISS AIR SYSTEM FOR LOW ENERGY GREEN BUILDING

LCA of a curtain wall system for a green building [7] showed the impacts of transport distance, production (Fig 4), environmental impact (Fig 5) as well as global warming potential (Fig 6).

Material Inputs	Unit	Quantity
Glass plate Thickness 8 (external plate)	km	202
HPL wood decor (external plate)	km	191
Cleaning detergent	km	666
Rigidur gypsum fibreboards (internal plate)	km	329
Aluminium foil, soft	km	148
Spacer bar	km	1733
Connector for spacer bar	km	1733
Structural adhesive meta methyl acrylate	km	236
Structural adhesive activator	km	236
CO <sub>2</sub> (insulating gas)	km	175
Steel tube	km	15
Polyamide profile	km	931
Polysulfide component A	km	171
Polysulfide component B	km	171
EPDM gaskets 3B	km	83
EPDM gaskets 2A	km	83
Carrier of EPDM gaskets	km	547
Silicon glue for gasket, SILIRUB EPDM	km	55
Self-tapping screws for mounting bar	km	115
Screw for mechanical guard JZ3-S	km	115
Screw (7504N)	km	3
PVC facade anchor for self tapping screws	km	15
Mechanical guard, stainless steel Duplex 1.4462	km	15
Staples	km	91
Hot melt 802158	km	191
Ethanol for cleaning	km	52
<b>Packaging</b>		
Wooden pallet	km	14
Polyethylene foil, 40mic	km	12
Polystyrene pads, 15 mm	km	51
Polyethylene foam sheet, 1 mm	km	52
Stretchable foil, 30mic	km	52

Material Inputs	Unit	Product 1	Product 2	Product 3	Product 4
Glass plate Thickness 8 (external plate)	kg	20	25	30	0
HPL wood decor (external plate)	kg	0	0	0	17,4
Cleaning detergent	kg	0,05	0,05	0,05	0,05
Water	kg	5	5	5	5
Rigidur gypsum fibreboards (internal plate)	kg	18	18	18	18
Aluminium foil, soft	kg	0,3	0,3	0,3	0,3
Spacer bar	kg	0,8	0,8	0,8	0,8
Connector for Spacer bar	kg	0,503	0,503	0,503	0,503
Structural Adhesive meta methyl acrylate	kg	0,07	0,07	0,07	0,07
Structural Adhesive Activator	kg	0,01	0,01	0,01	0,01
CO <sub>2</sub> (insulating gas)	kg	0,3	0,2	0,2	0,2
Steel tube	kg	2,3	2,2	2,2	2,2
Polyamide profile	kg	2,3	2,2	2,2	2,2
Polysulfide component A	kg	1,3	1,3	1,3	1,3
Polysulfide component B	kg	0,1	0,1	0,1	0,1
EPDM gaskets 3B	kg	0,2	0,2	0,2	0,2
EPDM gaskets 2A	kg	0,3	0,3	0,3	0,3
Carrier of EPDM gaskets	kg	1,1	1,1	1,1	1,1
Silicon Glue for gasket, SILIRUB EPDM	kg	1,4E-04	1,4E-04	1,4E-04	1,4E-04
Self-tapping screws for mounting bar	kg	2,0E-03	2,0E-03	2,0E-03	2,0E-03
Screw for mechanical guard JZ3-S	kg	5,7E-04	5,7E-04	5,7E-04	5,7E-04
Screw (7504N)	kg	1,1E-03	1,1E-03	1,1E-03	1,1E-03
PVC facade anchor for self tapping screws	kg	1,1E-03	1,1E-03	1,1E-03	1,1E-03
Mechanical guard, stainless steel Duplex 1.4462	kg	0,02	0,02	0,02	0,02
Staples	kg	9,2E-04	9,2E-04	9,2E-04	9,2E-04
Hot melt 802158	kg	5,0E-04	5,0E-04	5,0E-04	5,0E-04
Ethanol for cleaning	kg	0,03	0,03	0,03	0,03
<b>Packaging</b>					
Wooden pallet	kg	23	23	23	23
Polyethylene foil, 40mic	kg	0,05	0,05	0,05	0,05
Polystyrene pads, 15 mm	kg	0,5	0,5	0,5	0,5
Polyethylene foam sheet, 1 mm	kg	0,03	0,03	0,03	0,03
Stretchable foil, 30mic	kg	0,3	0,3	0,3	0,3
<b>Energy</b>					
Power	MJ	42	42	42	42
<b>Output Process Data</b>					
<b>Outputs</b>					
Qbiss Air Panel	kg	40	51	56	43
Wastewater	kg	5	5	5	5
Waste residues (inert)	kg	0,9	0,9	0,9	0,9
<b>Emissions</b>					
alveolar dust	kg	1,0E-08	1,0E-08	1,0E-08	1,0E-08
β-propanol	kg	2,3E-07	2,3E-07	2,3E-07	2,3E-07
methylmethacrylate	kg	6,9E-06	6,9E-06	6,9E-06	6,9E-06
styrene	kg	3,3E-08	3,3E-08	3,3E-08	3,3E-08
Carbon dioxide	kg	4,1E-05	4,1E-05	4,1E-05	4,1E-05

Fig 4: The impact of transport distance (left) and production information (right)

RESULTS OF THE LCA - ENVIRONMENTAL IMPACT:													
Parameter	Einheit	Manufacturing Product 1			Manufacturing Product 2			Manufacturing Product 3			Manufacturing Product 4		
		A1	A2	A3	A1	A2	A3	A1	A2	A3	A1	A2	A3
GWP	[kg CO <sub>2</sub> - Äq.]	71	0,71	8,956	76	0,76	8,954	82	0,81	8,954	52	0,68	8,954
ODP	[kg CFC11- Äq.]	2,60E-06	1,45E-09	2,0129E-06	2,86E-06	1,55E-09	2,0128E-06	3,12E-06	1,65E-09	2,0128E-06	2,41E-06	1,37E-09	2,0128E-06
AP	[kg SO <sub>2</sub> - Äq.]	0,27	0,0032	0,187939	0,30	0,0034	0,187936	0,32	0,0036	0,187936	0,20	0,0030	0,187936
EP	[kg PO <sub>4</sub> <sup>3-</sup> - Äq.]	0,038	0,00072	0,00260	0,043	0,00077	0,00259	0,048	0,00082	0,00259	0,027	0,00068	0,00259
POCP	[kg Ethen Äq.]	0,029	0,00033	9,8053E-03	0,031	0,00035	9,8051E-03	0,033	0,00037	9,8051E-03	0,026	0,00031	9,8051E-03
ADPE	[kg Sb Äq.]	7,73E-04	1,53E-08	1,0182E-06	8,12E-04	1,63E-08	1,0179E-06	8,51E-04	1,74E-08	1,0179E-06	6,21E-04	1,45E-08	1,0179E-06
ADPF	[MJ]	980	9,9	127,413	1049	10,6	127,409	1117	11,3	127,409	999	9,4	127,409
Caption	GWP = Global warming potential; ODP = Depletion potential of the stratospheric ozone layer; AP = Acidification potential of land and water; EP = Eutrophication potential; POCP = Formation potential of tropospheric ozone photochemical oxidants; ADPE = Abiotic depletion potential for non fossil resources; ADPF = Abiotic depletion potential for fossil resources												

Fig 5: Environmental impact of Qbiss Air

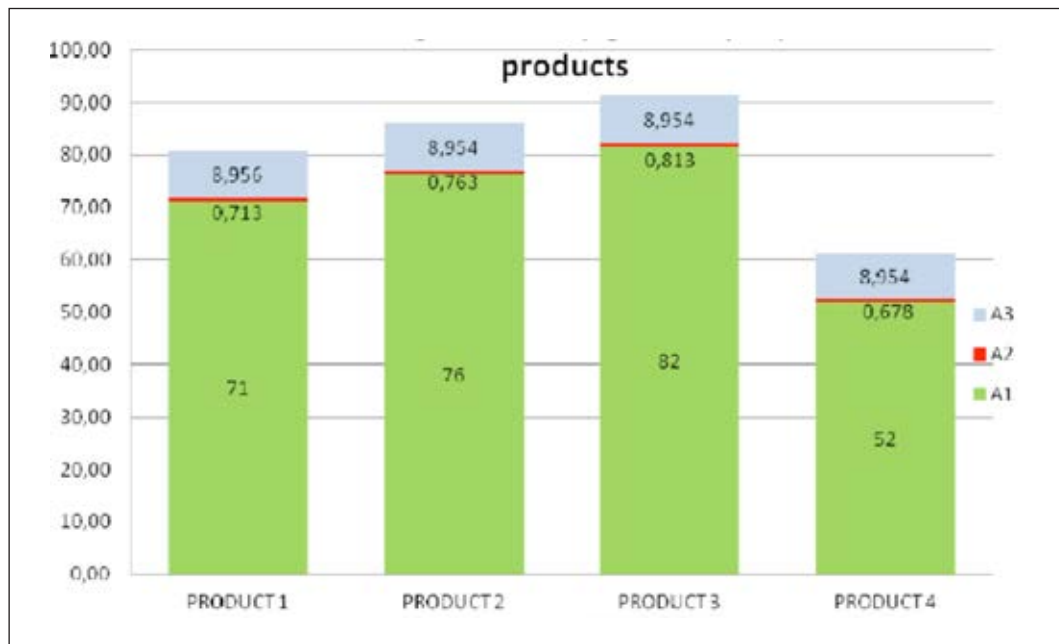

Fig 6: Global warming potential of 4 different types of Qbiss Air panel

In a Kindergarten Trebnje, Trimo d.d. has shown how a public building should fulfil all the requirements regarding aesthetic, living comfort and especially energy consumption. To meet those requirements we used triple glazed widows and add 10 cm of mineral wool insulation (Fig 7 and Fig 8).



Fig 7: Front facade and an interior of Kindergarten Trebnje

Kindergarten Trebnje is the best example showing the incorporation of different Trimo's products into a building of 2700 m<sup>2</sup> with highest living comfort for 300 children and more than 50 employees (Fig 8).



U<sub>g</sub> = 0,62 W/m<sup>2</sup>K – triple glazing  
 U<sub>g</sub> = 0,16 W/m<sup>2</sup>K – Qbiss Air + 10 cm MW



Fig 8: Back facade and an atrium

In Slovenia all public building should provide at least 25% of energy consumption with renewable energy resources (according to PURES) so in Kindergarten Trebnje a wooden chip fired boiler with 150 kW of nominal power is installed. All together Kindergarten Trebnje has Energy Performance Certificate (EPC) class B2 [8] which means less than 35 kWh/m<sup>2</sup> per year (Fig 9). Regarding energy consumption per m<sup>3</sup> we achieved a very good result 7.2 kWh/m<sup>3</sup> what is much less than 12,9 kWh/m<sup>3</sup> (max regulatory).



Fig 9: Energy for heating per year

## 4. CONCLUSIONS

Qbiss Air system is now in certification procedure. It has Slovenian technical approval (STS) and declaration of conformity from September 2011 and according to certification procedure we expect European technical approval (ETA) by the end of 2012. Our recent work is and will be based on:

- improving U values of Qbiss Air panels to  $U_{\text{system}} < 0.10 \text{ W/m}^2\text{K}$  – i.e. with inserted vacuum elements,
- upgrading standard non transparent Qbiss Air (QA) panels with translucent (QAT) and transparent / QATT) version (Fig 10).



Fig 10: Prototypes of Qbiss Air translucent (left) and transparent panel (right)

## REFERENCES

- 1 Green Building – enhanced energy efficiency for non-residential buildings, Deutsche Energie-Agentur GmbH, Berlin 2006
- 2 <http://www.bsria.co.uk/news/breeam-or-lead/>
- 3 <http://sunhomedesign.wordpress.com/what-is-sustainable-design/>
- 4 ŽNIDARŠIČ, Matjaž, KRALJ, Aleš. Trendi razvoja visokoizolacijskih materialov v sodobnih stavbah, Industrijski forum IRT, Portorož, 6. in 7. junij 2011. *Vir znanja in izkušenj za stroko : zbornik foruma*. Škofljica: Profidtp, 2011, str. 165-170
- 5 KRALJ, Aleš, ŽNIDARŠIČ, Matjaž, JAPELJ FIR, Mojca, REMEC, Črtomir. Gas-filled panels as a high insulation alternative for 21st century buildings envelopes. V: *Proceeding of WEC 2011*. Zurich: Swiss Society of Engineers and Architects SIA, 2011, str. [1-8]
- 6 ŽNIDARŠIČ, Matjaž, KRALJ, Aleš. Nov visoko-izolacijski stavbni ovoj, Industrijski forum IRT, Portorož, 7.-8. junij 2010. *Vir znanja in izkušenj za stroko : zbornik foruma*. Škofljica: Profidtp, 2010, str. 133-136
- 7 Environmental product declaration (draft): Self supported Light Weight Insulation Panel Qbiss Air, Trimo d.d., Institut Bauen un Umwelt, 2012
- 8 Izračun indikatorjev za energetske izkaznice novega vrtca v Trebnjem, Delovno poročilo, ZRMK, Ljubljana, 2011

# **Dr. Roumiana Zaharieva, Dr. Yana Kancheva, Bulgaria**

## **Measures to Decrease the Environmental Footprint of Concrete**

University of Architecture, Civil Engineering and Geodesy

E-mail: [roumiana.zaharieva@gmail.com](mailto:roumiana.zaharieva@gmail.com) / [ykancheva@gmail.com](mailto:ykancheva@gmail.com)



### **ABSTRACT**

Concrete industry, being one of the largest in the world, has a significant impact on environment. An overview of the key factors causing this negative influence during the different stages of concrete's life cycle (from raw materials acquisition and processing through manufacturing of concrete, use, maintenance and repair of concrete structures to the demolition and recycling) is made. The main difficulties when estimating that environmental footprint are discussed. Potential for reuse and recycling of concrete waste is studied in the framework of EU policy and Bulgarian legislation. Some measures towards improving sustainability of concrete are suggested by authors.

## 1. INTRODUCTION

Concrete has been used for over 2,000 years, but its sustainability became an issue only during the last 20 years [1]. Concrete is the most used construction material, chosen for meeting all technical, durability, aesthetic, cost and other design criteria. However, the additional ways that concrete contributes to the triple bottom line of social progress, economic growth and environmental protection are often overlooked. While the technical and economic benefits of concrete use are more or less known and recognized, the environmental benefits and/or challenges are sometimes underestimated. The production of concrete annually amounts to 1,5 to 3 tonne per capita in the industrialized world: this makes the concrete industry including all of its suppliers a major player in the building sector. Thus, improving the sustainability of the concrete industry automatically will lead to significant improvements in the building sector as a whole [2].

The challenge of evaluation of concrete footprint is to range over its huge variety in composition, manufacturing, application, service life, etc. - table 1. Moreover, it is not enough to assess the environmental impact of concrete components only, because their proportions, treatment of concrete, maintenance required, etc., influences significantly concrete's properties and durability and thus, having different impact on environment. There is an interaction between concrete and environment - concrete has an environmental impact in terms of use of raw materials, energy and water and release of waste and emissions - fig.1., but the environment has also a significant impact on the concrete causing chemical, physical and/or biological corrosion - fig.2.

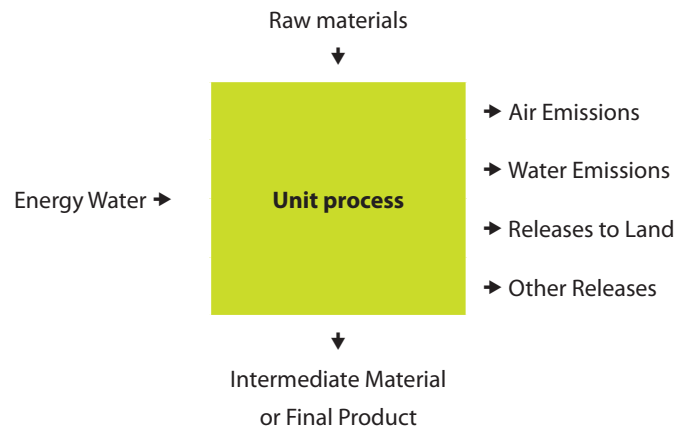

Fig 1. Environmental impact of concrete products (Acc. to a modified figure in [3]).

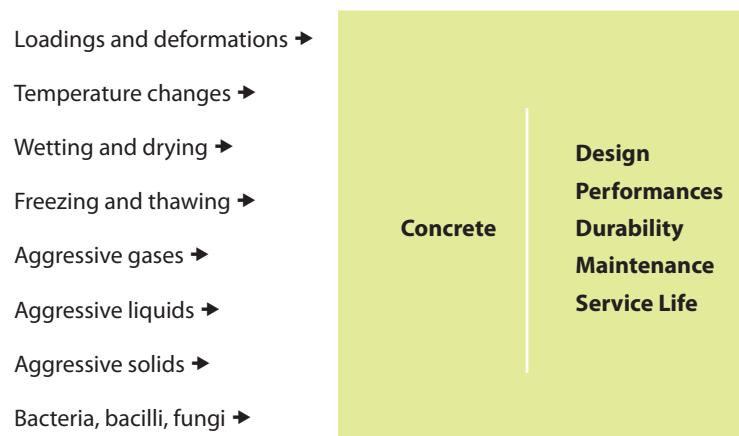

Fig 2. Impact of the environment on concrete.



Table 1. Classification of concrete

According to the bulk density in dry condition (DD)	Heavy concrete – DD above 2600 kg/m <sup>3</sup> Ordinary concrete – DD between 2000 and 2600 kg/m <sup>3</sup> Light weight concrete – DD between 800 and 2000 kg/m <sup>3</sup> Extremely light weight concrete – DD less than 500 kg/m <sup>3</sup>
According to the class of compressive strength (C for ordinary concrete and LC for lightweight concrete)	Normal concrete – C less than C 50/60 High strength concrete – C above C 50/60 till C100/115 LC above LC 50/55 for light weight concrete High performance concrete – compressive strength between 115 MPa and 150 MPa. Ultrahigh performance concrete – compressive strength above 150 MPa (till 800 MPa)
According to the purpose (functions) of concrete	Concrete for reinforced and non reinforced structures for Buildings and Facilities Concrete for Hydrotechnical structures (additional requirements for water impermeability and frost resistance) Concrete for Transport Structures and Pavements (requirements for frost resistance, bending strength and resistance to abrasion) Concrete resistant to high temperatures (above 400 °C) Concrete for thermal insulation (low density requirements) Radioactive protection concrete (very high density requirements) Acid-resistant concrete
According to the binder's type	Cement Concrete (Portland cement and other blended cements) Alkali activated slag concrete (alkali activated slag cement ) Silicate concrete (lime based) Acid resistant concrete (acid resistant cement based on water glass) Polymeric concrete (synthetic resins) Asphaltic concrete (bituminous binders)
According to the aggregate porosity	With dense aggregate (sand, gravel, crushed stone) With porous aggregate (manufactured aggregate resulting from a thermal modification)
According to the maximum aggregate size (D <sub>max</sub> )	Coarsely grained concrete (D <sub>max</sub> >40 mm) Medium grained concrete (8mm<D <sub>max</sub> <40 mm) Finely grained concrete (4mm<D <sub>max</sub> <8 mm) No fines concrete (fine aggregate only up to 10%) Reactive Powder Concrete (D <sub>max</sub> =0,5 mm)
According to manufacturing process	Cast in situ Pre-cast structural elements (normal reinforcement or pre-stressed reinforcement) Manufactured small size elements (blocks, kerbs, pipes, etc.)
According to hardening conditions	Normally hardened – temperature below 40 °C, atm. pressure Thermally treated – temperature above 40 °C, atmospheric pressure Autoclaved – pressure of 0,8 to 1,3 MPa and temp. of 175 to 200 °C.
According to the environmental impact group (acc. to EN 206-1)	Class X0 – without risk of corrosion or aggressive impacts on concrete Classes XC1 to XC4 – corrosion due to carbonation. Depends on the environment's relative humidity Classes XD1 to XD3 – corrosion due to chlorides different than those in sea water Classes XS1 to XS3 – corrosion due to sea water chlorides Classes XF1 to XF4 – repetitive alternating freezing and thawing Classes XA1 to XA3 – corrosion due to the aggressive impact of ground water or soils
According to the designed service life (acc. to EN 1990)	50 years for buildings 100 years for monumental building structures, bridges and other civil engineering structures

Usually, when some measures to ensure the resistance of concrete to the environmental impacts are taken, they reflect into a reduced environmental impact of concrete. For example, the more durable concrete requires less maintenance, leads to smaller (over the time) quantity of waste and to a smaller consumption of raw materials and energy, because of the extended service life. On the other hand, the benefits for the environment by using concrete (instead of other alternative materials) shall also be taken into consideration.

## 2. ENVIRONMENTAL ASPECTS OF CONCRETE

### 2.1. Sustainability of building materials and social benefits

The characteristics of sustainable building materials in general can be summarized into the following categories:

- Minimizing the resource use;
- Low ecological impacts;
- Low or no human and environmental health risks;
- Contribution to sustainable strategies in construction [3] and thus to sustainable development as a whole.

While discussing the sustainability of concrete, its social benefits shall not be forgotten.

The safety is actually the major social benefit of concrete. Concrete, as a structural material, as well as a building envelop, has the ability to withstand quite well the environmental deteriorating mechanisms, but also disasters such as earthquakes, tornadoes, hurricanes, fires, flooding, etc. Concrete is not damaged by water; concrete that does not dry out continues to gain strength in the presence of moisture. When immersed and submerged in water, concrete absorbs relatively small amounts of water over long periods of time, and the concrete is not damaged. In flood-damaged areas, concrete buildings are often salvageable. Concrete dams and levees are used for long-lasting flood control.

Concrete does not contribute to moisture problems in buildings if it is not enclosed in a system that does not let it breathe or dry out, trapping moisture between the concrete and other building materials.

A well designed concrete building that takes advantage of long floor spans with column-free space is adaptable to a variety of occupants.

### 2.2. Basic environmental aspects of concrete production. Bulgarian examples.

#### 2.2.1 LCA tool and environmental categories

The environmental footprint of concrete is created during the whole life cycle of the product - from raw materials acquisition and processing through manufacturing of concrete, use, maintenance and repair of concrete structures to the demolition, recycling and eventually disposal.

Life cycle analysis (LCA) has been identified as a powerful tool for studying and making comparison of environmental footprint of materials in sustainable construction context, subject that the most important stages of the products life cycle (very often the exploitation period is omitted in the case of a concrete structure, which might be justified for buildings, but not for transport facilities requiring a serious maintenance) are evaluated and all relevant environmental aspects are examined (indoor air quality is not applicable to ordinary concrete which is usually inert). Other major issues of LCA application are the appropriate choice of the so-called functional unit (1m<sup>3</sup> of cast in situ concrete, or a pre-cast element, or 1m<sup>2</sup> of a wall, etc.) and the considered period of time (a stipulated period of time, service life, whole life

cycle, etc.) , because the final results might be influenced significantly. The above conditions show how subjective the evaluation might be, although unified evaluation system has been applied.

Life-Cycle Impact Assessment (LCIA) is a component of the altogether Life-Cycle Analysis (LCA) of a product with regard to understanding and assessment of the relationship between environmental aspects and a product system during its life-cycle. LCIA reviews only environmental aspects and sometimes not all impacts are included. However, even a brief review of the most used environmental aspects such as:

- Primary energy, non-renewable [MJ]
- Primary energy, renewable [MJ]
- Global Warming Potential (GWP 100) [kg CO<sub>2</sub>-eqv.]
- Ozone Depletion Potential (ODP) [kg R11-eqv.]
- Acidification of Soil and Water Potential (AP) [kg SO<sub>2</sub>-eqv.]
- Eutrophication Potential (EP) [kg PO<sub>4</sub>-eqv.]
- Photochemical Ozone Creation Potential (POCP) [kg Ethene-eqv.]

demonstrates how complex would be the evaluation process for concrete. Binding materials production, especially cement industry, have the biggest contribution to the aforesaid aspects. It holds 5-7 % of the anthropogenic carbon dioxide. CO<sub>2</sub> due to chemical reactions during cement production is about 30% of all non-fuel combusted CO<sub>2</sub>. Only metallurgical industry exceeds this percent.

It has to be admitted that during the latest 10-15 years cement manufacturers throughout the world (including in Bulgaria) have been taking measures for reduction of the harmful emissions – e.g. upgrading production processes, installation of new equipment for reducing greenhouse gas and dust emissions, etc. However, low-clinker cements, incorporating slag, fly ash and/or silica fume has the greatest contribution to reducing the harmful influence as they help for a better management of industrial waste as well. Reducing cement quantity for 1 m<sup>3</sup> concrete blend (by means of mineral and chemical additives) also reduces the negative effects on nature. As mentioned in [4], regarding autoclaved aerated concrete (AAC), cement production accounts for more than 70% of all CO<sub>2</sub> emissions throughout the whole life-cycle of AAC, as well as over 50% of soil and water acidification potential. The contribution of production processes to acidification is about 25%. Acquisition, processing and transport of aggregates have bigger influence on resource and energy consumption than on CO<sub>2</sub> emissions [4].

### **2.2.2 Resources consumption.**

The mining, processing, and transport of huge quantities of aggregate, in addition to billions of tons of raw materials needed for the cement manufacture, consume considerable energy and adversely affects the ecology of virgin lands. Besides landscape damages, acquisition of crushed stone has some other consequences – extraction and processing activities (drilling, detonation, crushing, sorting, transport) generate harmful emissions, dust and noise, which has a serious influence on eco-systems nearby. Rivers are also affected through changes in river beds and biological diversity – soils have been dehydrated decreasing their fertility, habitats of many river and riverside organisms have been damaged.

Extraction of sand and gravel from river can indirectly lead to disruptions in foundations of bridges and protective equipment, higher levels of dust and noise, aesthetical changes in landscape, destroying agricultural areas, etc.

In Bulgaria, additional serious problem is the illegal (above the permitted quantities or not permitted at all) extraction of aggregates which has significant negative environmental and economical results.

One way to reduce these consequences is the use of alternative aggregates – from industrial waste (slags, fly ash, rubber, sludge, etc.) and from recycled construction waste (concrete and ceramics).

### **2.2.3 Renewable and non-renewable energy**

According to Calkins [3], cement production accounts for the greatest deal of the energy consumed during

the whole life-cycle of concrete. Cement comprises a small part of concrete mixture (about 10%), but accounts for 92% of the whole energy consumed. Fuels and gas are the primary energy sources, but alternative sources are also frequently used such as domestic and industrial waste. Currently, "TITAN – Zlatna Panega Cement" substitutes 10% of its main fuel, which is coal, with used tires, as their ambition is the substitution to be 50% by 2015. This will save about 35000 tons of coal and approximately 50000 tons of carbon dioxide each year [5]. Holcim Bulgaria AD declare 16000 tons less consumed coal for the periods 2006-2008 due to use of alternative fuels. 21000 tons of greenhouse gas and CO<sub>2</sub> emissions have been saved for the same period [6].

Another approach for reducing energy consumption is by using the dry process for cement production (applied by Devnya Cement AD since 2008) which is less energy consuming and provides a larger production capacity.

Power plants from renewable sources have been encouraged in Bulgaria during the past few years in conformity with European strategy 20/20/20 – currently renewable energy is about 16% of the whole energy produced in the country. It is accounted that 5-6% of energy needed for production of cement and concrete comes from Hydroelectric power plants.

#### **2.2.4. Consumption of clean water**

Water is an important resource and demands a proper management. If the mixing water required for production of 1 m<sup>3</sup> of fresh concrete is about 100-250 liters (the quantity depends on the desired workability and designed properties of hardened concrete), water consumption during the production of that 1m<sup>3</sup> fresh concrete is at least three times larger. Large quantities of water are used also during building with concrete. It is hard to stimulate water savings in Bulgaria as most concrete batching plants have their own water sources and pay small taxes for their exploitation. Although the use of recycled water is allowed by BDS EN 1008, there is no application in Bulgaria, with one positive exception only - in the manufacturing process of cellular concrete by XELLA Bulgaria.

#### **2.2.5. Waste disposal and/or Recycling**

End of concrete's life-cycle is connected with generation of significant quantities of solid waste. According to National Statistical Institute, about 400 thousand tons construction waste has been generated in Bulgaria in 2010 – mainly concrete waste, ceramics and asphalt waste, i.e. waste suitable for reuse and recycling. Unfortunately, this waste is so far mainly disposed, because of lack of recycling experience, lack of knowledge, no market for recycled products, etc. In the strictest sense, recycling of a material would produce a fresh supply of the same material—for example, demolished concrete would be converted into new aggregates (recycled aggregates for bound applications). However, this is often difficult or too expensive (compared with producing the same product from raw materials or other sources), so "recycling" of many products or materials involves their reuse in producing different materials (e.g., crushed stone for road sub base) instead. Concrete provides excellent opportunities for recycling – about 70-80% can be recycled as coarse and fine aggregates for concrete and asphalt-concrete, as well as crushed stone and filler. Besides, some types of concrete allow reuse, e.g. autoclaved aerated concrete. In relation to European Directive 2008/98/EC on waste a regulation is in preparation in Bulgaria that will demand recycling of 70% of the construction waste achieved until 2020. The first targeted application of that recycled concrete will be in road and landscape construction, but recycled materials are suitable for concrete production as well. Only concrete from contaminated areas shall be landfilled.

#### **2.2.6. Emissions to water and soil**

Contamination of water basins in Bulgaria due to concrete industry is a result mainly of irresponsibility and non-observance of laws by some manufacturers. Soil damages are result both of inert materials acquisition (section 2.2.2.), and intensive overbuilding during the past 10 years. As a result, free of buildings and fertile areas are lost, landscape is changed, habitats have been damaged. Specific radioactive contamination can be released only when radioactive aggregates and/or additives are used.

### 2.2.7. Other environmental issues

Concrete is considered to be harmless to humans and environment – releases no emissions, non-toxic, requires limited maintenance. This and its more popular properties (durability, load bearing, insulation, non-combustible, frost resistant, resistant to aggressive agents, good workability) make concrete a preferred construction material. A well-designed combination with insulation materials provides an excellent indoor climate, reduction of energy consumption in buildings, efficient and durable construction. Concrete has reduced transportation costs as it is a locally available material.

Thermal mass of concrete contributes to operating energy efficiency and reduced cooling costs, under certain climatic conditions. Longer lasting structures are finally reducing energy needs for maintenance and reconstruction. Actually, over the lifetime of a building, the operating energy has a far greater impact than embodied energy. The embodied energy of the materials, in this example, represents only 3 to 13 percent of total energy use over a 75 - 80 year building life.

There is no absolute need for additional interior or exterior finishes: Polished concrete floors do not require carpeting. Exposed concrete surfaces do not require paints or sealants. Light reflectance should be considered, too - light coloured walls reduce interior lighting requirements. Concrete provides satisfying indoor air quality: no off-gassing and no toxicity or Volatile Organic Compounds (VOCs).

Concrete does not sustain mould growth and can be easily cleaned.

Permeable concrete pavement and interlocking concrete pavers can be used to reduce runoff and allow water to return to the water table.

Concrete is used in the treatment of nuclear and other hazardous waste (pesticides), too.

## 3. LEGISLATION FRAMEWORK AND BEST PRACTICES

One approach toward stimulating demand and supply of environmentally friendly building materials is by development of appropriate legislation. Although there are several sets of international standards (ISO, EN) on Sustainable Construction, only a few of them deal with specific features of building materials (including concrete) sustainability assessment. ISO 14025:2006 establishes the general principles and specifies the procedures for developing Type III environmental declaration programmes and Type III environmental declarations (EPD). ISO 21930:2007 complements ISO 14025 for the EPD of building products and provides the principles and requirements for type III environmental declarations (EPD) of building products, as well as contains specifications and requirements for the EPD of building products.

A draft standard has been recently prepared in USA to track and report the environmental footprint of concrete. The standard is expected to help people in the building industry meet Architecture 2030's 2030 Challenge for Products. Launched a year ago, the challenge calls for dramatic reductions in energy consumption and greenhouse gas emissions related to the manufacture and transportation of construction materials. Use of these standards (Product Category Rules/PCRs) will enable concrete producers to report the 'environmental footprint' (Environmental Product Declaration/EPD) of different concrete mixes and enable architects and engineers to specify low impact concrete [7].

In EU countries, the Construction Products Regulation (305/2011/EU - CPR), replacing the Construction Products Directive (89/106/EEC - CPD) is laying down harmonised conditions for the marketing of construction products. It specifies the basic requirement for construction works such as Mechanical resistance and stability, Safety in case of fire, Hygiene, health and the environment, Safety and accessibility in use, Protection against noise, Energy economy and heat retention, known by CPD, but it introduces a new requirement for "Sustainable use of natural resources". The basic requirement for construction works on

sustainable use of natural resources should notably take into account the recyclability of construction works, their materials and parts after demolition, the durability of construction works and the use of environmentally compatible raw and secondary materials in construction works. For the assessment of the sustainable use of resources and of the impact of construction works on the environment Environmental Product Declarations should be used when available. The CPR has already entered into force. However, the main parts of its substantial Articles shall apply first from 1 July 2013.

Some of EU countries have developed, to a different extent, their own strategies and legislation in regards with the sustainable construction. For example, in United Kingdom, a holistic Sustainable Construction policy is being developed and applied. This policy sets out the framework through which the requirements of a number of national, regional and local polices that aim to achieve sustainable development are met. It will also help to reduce our contribution to climate change and build in adaptation to the changing climate though good design. A joint industry and government strategy to deliver sustainability in construction was elaborated in 2008 [8]. "British Precast", as the trade association for the precast concrete industry in the UK, had undertaken to develop a sector sustainability strategy for that industry [9]. The Green Guide is part of BREEAM (BRE Environmental Assessment Method) and represents an accredited environmental rating scheme for buildings, aiming to provide a 'green guide' to the environmental impacts of building materials which was easy-to-use and soundly based on numerical data. The Green Guide contains more than 1500 specifications used in various types of building. The information on the relative environmental performance of some materials and components is periodically updated in order to reflect both changes in manufacturing practices, the way materials are used in buildings, and our evolving environmental knowledge [10].

In order to simplify the assessment and to allow wider group of experts to make proper decision, BASF created a tool, called Eco-Efficiency Analysis Tool which won the Experts Choice for Most Innovative Product (Business Software) at World of Concrete Event in 2011. The Eco-Efficiency Analysis tool from BASF is a first-of-its-kind, third party-validated business software that quantifies the environmental and economical impacts of concrete and masonry mixtures. Most environmental analyses currently being used in the concrete industry are limited to energy consumption and air emissions. However, the "carbon footprint" alone does not provide a meaningful environmental picture. The Eco-Efficiency Analysis creates a customized, comprehensive report compare up to five different optimized concrete mixtures in a full spectrum of environmental impact areas. Construction stakeholders use the report to make informed business decisions on the sustainability of concrete and masonry mixes. The tool accesses data mined from BASF's in-house records, industry associations, third-party consultants and governmental agencies. The innovative uses the cradle-to-gate analysis that begins with the extraction of raw materials extending through the production of a unit volume of concrete for the comparison. The tool examines the effects of concrete ingredients and mix proportions in six environmental impact categories: energy consumption, air emissions, toxicity potential, health and risk potential, consumption of raw materials, and land use. It also factors in costs and transportation distances of raw materials, and incorporates social relevance based on various weighting factors [11].

#### 4. CONCLUSIONS AND RECOMMENDATIONS

As stated by P.K. Mehta and P.J.M. Monteiro, a new vision shall be promoted: in a nature - centered capitalism, the environment shall no longer be treated as a minor factor of production but rather an envelope containing, provisioning, and sustaining the entire economy [12]. Both in developed and developing countries, gigantic construction projects are underway in the metropolitan areas not only for new construction but also for rehabilitation or replacement of existing structures. Concrete used to be and continues to be the preferred building material and has to have its given role in sustainable construction [13].

Concrete has to be accepted as the preferred building material and has to have its given role in sustainable construction. The challenge is to anticipate future demands and develop and offer products and solutions that meet these continuously increasing demands:

- Develop and offer resource end energy efficient cement, with a lower carbon footprint: Blended Portland cements containing fly ash from coal-fired power plants and granulated slag from the blast-furnace iron industry provide excellent examples of industrial ecology because they offer a holistic solution to reduce the environmental impact of several industries, The high-volume fly ash or silica fume provides a promising of how we can build concrete structures in the future that would be far more durable and resource-efficient than those made of conventional portland-cement concrete. Again, the presence of a pozzolanic additives in a hydrating cement paste can lead to the processes of pore-size and grain-size refinement [12]; Energy efficiency might ne improved by using the excess heat for district heating and power generating, replace fossil fuel and natural resources, efficient emission reduction systems;
- Reduce the need of (natural) aggregate by avoiding ban sprawl, by building in the true cost of externalities into the price of concrete (taking into consideration not only the CO2 releases, but the road damage, the cyclists injured, etc.); by encouraging Renovation and Rehabilitation instead of Demolition and Replacement; by increased use of recycled aggregates [14].
- Concrete technology and mix design shall be improved: A better control of the bleeding tendency in concrete mixtures will be sought through proper aggregate grading, and the use of water-reducing and mineral additives; Fiber reinforcement of concrete that is subject to cyclic or impact loads will be commonly practiced. For developing countries, the use of natural organic fibers (such as sisal fiber and rice straw) presents interesting possibilities; The use of centralized and high-speed concrete mixers instead of truck mixing will help in the production of more homogeneous concrete than is generally available today;
- Develop specific properties of concrete depending on its application: lifespan and durability, thermal and sound insulation properties, flexibility and versatility, reusability; The use of high strength concrete and self compacting concrete should shall be encouraged.
- Introduction of uniform requirements for declaring environmental impacts of building products (by means of EPDs) would ensure actual and reliable data for further development of methodologies for assessment of ecological footprint of concrete. Clarifying of key aspects with their variety and relationships provides a basis for sustainable management of design and construction with concrete.
- As a conclusion, well designed concrete projects can contribute to social progress, economic growth and environmental protection for years to come.

## ACKNOWLEDGEMENT

The study is a part of the research project BN-128/2010 “Sustainable development principles in the architecture and the construction – opportunities for implementation in the education process”, undertaken within the Research and Development Centre at University of Architecture, Civil Engineering and Geodesy in Sofia, Bulgaria.

## REFERENCES

- Hendriks Ch.F., Sustainable Construction, ANEAS, The Netherlands, 2001.  
[http://www.eco-serve.net/publish/cat\\_index\\_69.shtml](http://www.eco-serve.net/publish/cat_index_69.shtml) (last visited on 4 June 2012).
- Calkins M., Materials for Sustainable Sites, WILEY, 2009.
- Environmental Product Declaration for Autoclaved Aerated Concrete. Xella Baustoffe GmbH. Duisburg, Germany. 2005.  
<http://www.titan.bg> (last visited on 12.03.2012)

<http://www.holcim.bg> (last visited on 12.03.2012)

<http://www.concreteconstruction.net/carbon-footprint/draft-standard-to-track-and-report-environmental-impacts-of-concrete-released-for-public-comment.aspx> (last visited on 22.05.2012)

<http://www.stockton.gov.uk/resources/techsvcs/envkway/dlcarbman/SustConst.pdf> (last visited on 22.05.2012)

<http://www.bre.co.uk/greenguide/page.jsp?id=2069> (last visited on 22.05.2012)

Holton I. R., 2009, DEVELOPING A SECTOR SUSTAINABILITY STRATEGY FOR THE UK PRECAST CONCRETE INDUSTRY, A dissertation thesis submitted in partial fulfilment of the requirements for the award of the degree Doctor of Engineering (EngD), at Loughborough University, 2009.

[http://construction.basf.us/index.php?page=about\\_newsRoom\\_news&select=75](http://construction.basf.us/index.php?page=about_newsRoom_news&select=75) (last visited on 22.05.2012)

<http://www.ce.berkeley.edu/~paulmont/CE60New/Concrete%20and%20the%20Environment.pdf>

Green Building with Concrete. Sustainable Design and Construction. Edited by G. Sabnis, CRC Press, 2011 (last visited on 22.05.2012)

<http://www.treehugger.com/green-architecture/why-concretes-colossal-footprint-is-more-complicated-than-you-think-and-why-that-matters-to-everyone.html> (last visited on 22.05.2012)





**Sabina Jordan, MSc<sup>(1)</sup>,  
Slovenia,  
Tilmann E. Kuhn, BSc Phys.<sup>(2)</sup>,  
Germany**

## **Ljubljana's Pilot Demonstration of an EU Project Cost Effective**

<sup>(1)</sup> Slovenian National Building and Civil Engineering  
Institute

<sup>(2)</sup> Fraunhofer Institute for Solar Energy Systems ISE

E-mail: [sabina.jordan@zag.si](mailto:sabina.jordan@zag.si)  
[tilmann.kuhn@ise.fraunhofer.de](mailto:tilmann.kuhn@ise.fraunhofer.de)

### **ABSTRACT**

The current European building stock has huge potential for improvement of energy efficiency and integration of renewables. Still there is not enough implementation in the existing non-residential sector, especially for high-rise office buildings where façade-integration is essential due to small roof area. The FP7 project COST EFFECTIVE is developing the technical and economical concepts and components for successful integration, supported by two pilot demonstrations. One of them is in Ljubljana, Slovenia, as a part of the ZAG's building. Together with 25 EU project partners ZAG is joining the forces to research, develop, show and monitor the concept of solar heating and cooling at the existing office building. Results will be used for optimisation of high-rise building retrofitting, looking forward to reducing energy consumption and for implementation of innovative technologies from COST EFFECTIVE project.

## INTRODUCTION

The existing building stock of the EU is estimated to be responsible for approximately 40% of the CO<sub>2</sub> emissions during its lifetime. It has also been assessed that existing EU building stock in general has a huge potential for improvement of the energy efficiency and the application of renewable technologies. The Energy Performances of Buildings Directive 2010 (EPBD) is forcing the use of renewable energy sources in buildings as well. Nevertheless, not enough attention in the built environment is directed toward refurbishment and the use of renewable energy in the non-residential sector.

A lot of effort will still need to be invested into the technological aspects as well as into business models. Special attention should be given to developing integrated concepts which can harvest the potential in the existing stock of the non-residential sector. The integrated concepts should use present technologies and custom-made technologies for this sector, especially for high-rise buildings where façade-integration is essential due to large energy demands and relatively small roof areas.

With the focus on that type of buildings the FP7 project COST EFFECTIVE is developing the technical and economical concepts and components for the successful integration in buildings during refurbishment. The basic intention is to progress the innovations to convert façades of existing non-residential high-rise buildings into multifunctional, energy-gaining components. The project concentrates on user centred solutions as well as on demonstration, evaluation and monitoring of the results on a large scale. Both, concepts and components were shown in two demonstrators with different climatic conditions: A Spanish pilot with a Mediterranean climate and a Slovenian pilot with a Central European climate. The pilots were designed for optimal performance of the system and for demonstration purposes.

## PILOT DEMONSTRATION IN LJUBLJANA

### The object of the pilot

The pilot demonstration in Ljubljana, Slovenia, as a part of the ZAG's building was built to research, develop, show and monitor the concept of solar heating and cooling at the existing office building. The energy source at the pilot is solar energy from two solar collectors types specifically developed in this project, air-heating vacuum tube collectors (VTC) and transparent glazing integrated solar thermal collector (TSTC).

The pilot concept consists of:

- Thermal insulation outside
- High performance windows
- Partially open-able windows
- External shading fixed
- External shading moveable
- Internal shading moveable
- Transparent (glazing integrated) solar thermal collectors (TSTC)
- Air-heating vacuum tube collectors (VTC)
- Thermally activated ceiling
- Smart lighting
- Building management system (BMS)

The pilot installation includes the offices on the 5<sup>th</sup> floor of the ZAG's building – about 109 m<sup>2</sup> net floor area (121 m<sup>2</sup> gross floor area) and about 343 m<sup>3</sup> net volume. The orientation of the offices is 15° toward SW. The refurbished offices are occupied by an IT department and a photo laboratory.

### The basic elements of the pilot

The idea of the pilot is to drive the heating and cooling of these 109 m<sup>2</sup> of office premises on solar energy from the solar collectors mounted on the façade using the so called TABS (thermally activated building

system). These collectors are installed at two different orientations and different locations on the building envelope: TSTCs on the upper part of the fire escape staircase façade with the orientation 30° SE and gross area of 27.8 m<sup>2</sup> and VTCs on the whole length of the catwalk fence of the 5<sup>th</sup> floor with the orientation 15° SW and gross area of 24.2 m<sup>2</sup>.

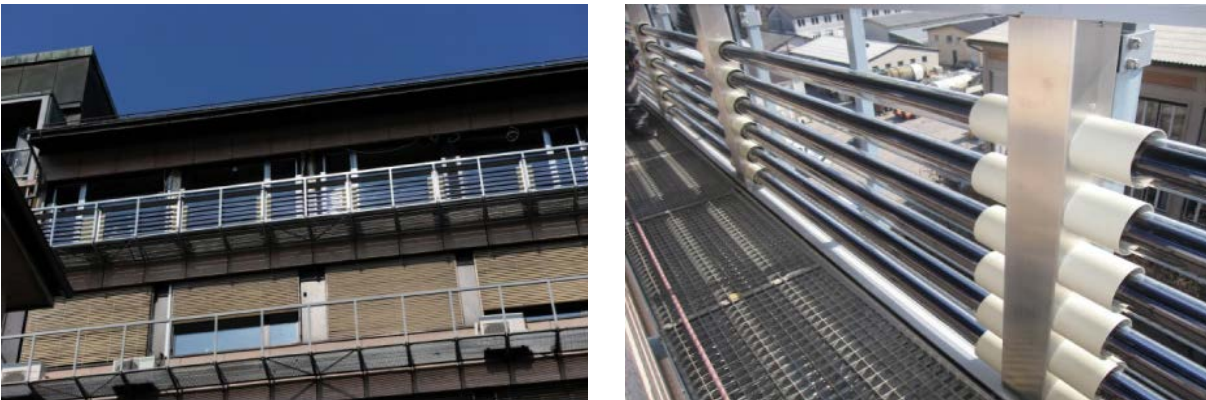

Illustration 1. Air-heating vacuum tube collectors on the pilot site.

The solar energy from the collectors is used for both heating and cooling of the offices. In the heating season the heat gained from the sun is stored in a heat storage tank and transferred to the heating/cooling ceiling elements. In summer conditions the heat is first transformed into cold via an adsorption chiller and then stored in a cold storage tank to be used for cooling in the heating/cooling ceiling elements. For both operating modes a backup energy supply is assured.

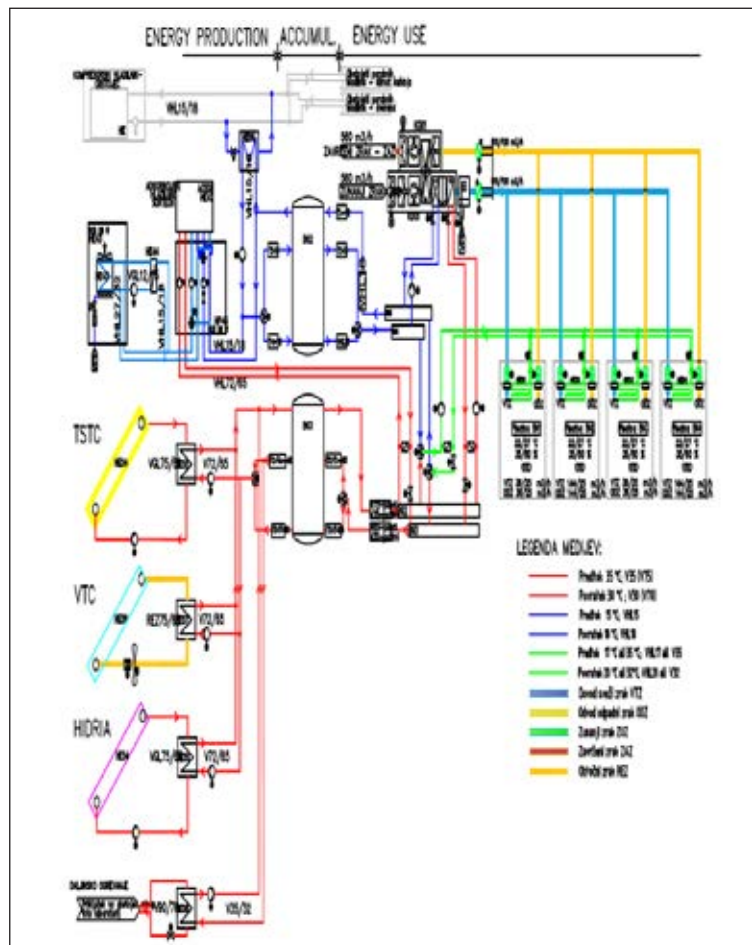

Illustration 2. The HVAC conceptual scheme.

The object of the project and the demonstration is to show the potential of new components and the two newly developed collectors. The primary purpose of the collectors in general is in delivering the solar energy and decreasing the non-renewable primary energy demand of the building. In this particular case two types of collectors are studied which can be incorporated into the building façade. They are not only interesting because of their façade integration capability and providing solar heat, but also because of their protection against overheating, glare protection and visual transparency. Since they are semi-transparent, both types of newly developed collectors contribute in the visual transparency of the envelope if integrated into the façade as a part of the window. Visual transparency of the building envelope is highly appreciated today, and is desired and anticipated by users and architects. Besides being energy efficient and cost effective the challenge for new collectors with façade integration capability is to be at least semi-transparent.

### The system and the users comfort

The pilot intention was also to demonstrate the energy efficient and user friendly heating and cooling system. It is made of heating/cooling ceiling elements. Panels covering approximately 60% of the ceiling are delivering energy for heating or cooling to the rooms by radiation, by conduction to the concrete ceiling (which activates the thermal mass of the concrete) and by natural convection. Working at relatively low heating and relatively high cooling temperatures (35°C/16°C) this system is among the most energy efficient. Furthermore the low temperature heating and high temperature cooling provides very good thermal comfort for the users.



Illustration 3. The heating/cooling ceiling panels in refurbished offices.

The whole system needs to be controlled by a Building management system (BMS). The BMS is managing all the essential elements of heating, ventilation and cooling (HVAC) systems and room automation via a computer-based control system installed in the building. It is also collecting measured values and giving commands to each part according to those measured values and in synchronization to logic and automation built into the BMS. The pilot is therefore equipped with all the required measurement devices, energy meters, controllers, operation parameters, etc. and is gathering data to be processed, stored and used in the BMS.

### The monitoring strategy

The monitoring strategy for the treated area includes monitoring of the envelope before and after renovation: visual observations and analyses, computer simulation, thermography of thermal bridges and airtightness. Furthermore it includes measurements and monitoring of the system performance, based on the measurements of all relevant parameters and user assessment.

The measurements will be used to evaluate the energy consumption of the building before renovation regarding the improvement of the building envelope, integrated HVAC system, electrical systems, lighting as well as to know the indoor environment quality associated to the opening/closing of the door and windows by the end user. The system itself is based on data, measured with permanent measurement systems integrated into the BMS and additionally measured data for performance evaluation.

For the evaluation of the components developed in the project, the transparent glazing integrated collectors (TSTC) and air heated vacuum tube collectors (VTC), some additional measurements of the components will be done.

The objective of the monitoring is to compile and analyse energy consumption of the pilot and the users comfort level during a given period of time and in addition to that, studying the building performance and its operating characteristics. All the measures taken will allow the energy efficiency evaluation of the refurbished part of the building.

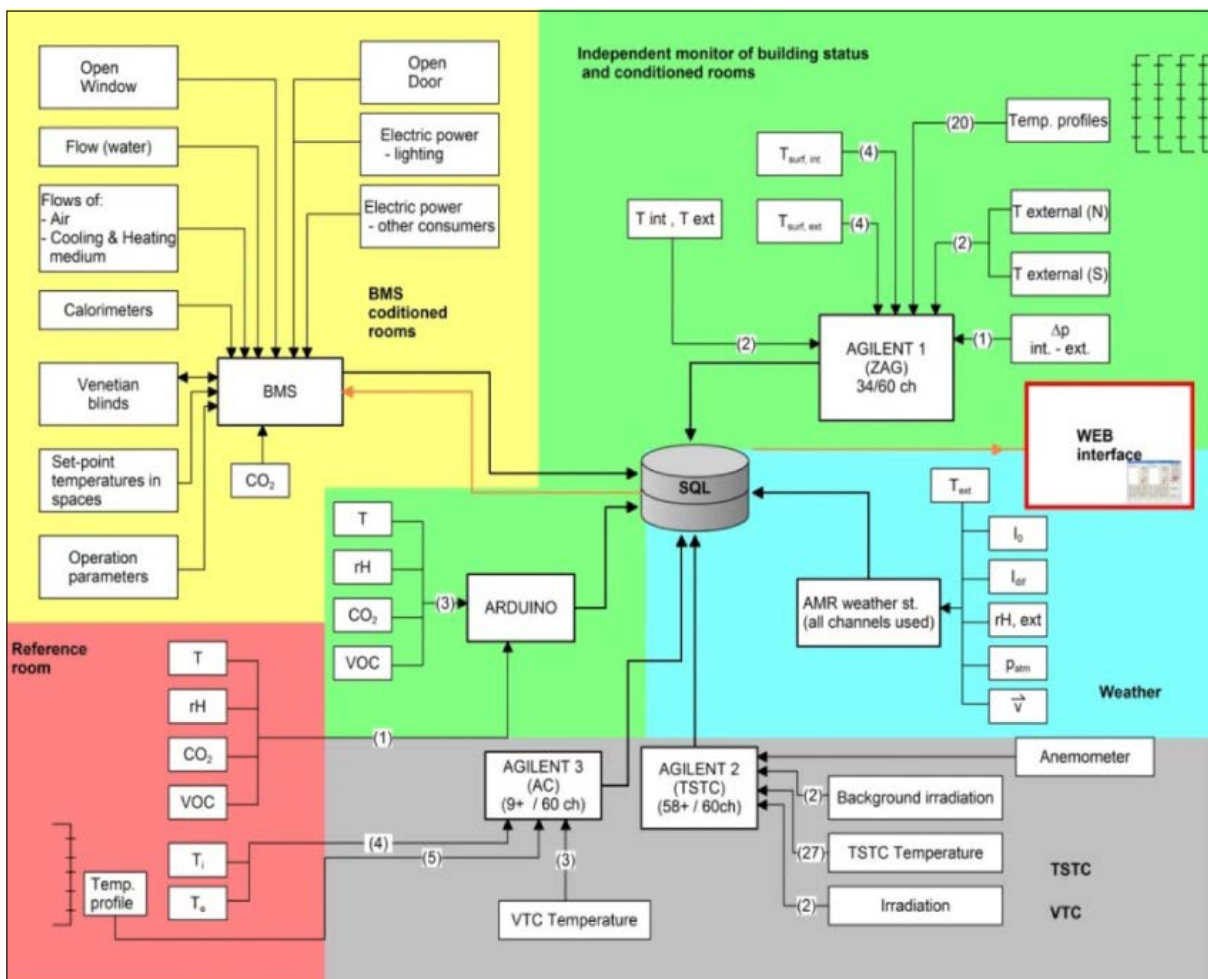

Illustration 4. General scheme of the monitoring system.

## THE REFURBISHMENT APPROACH

Predicted adaptation, improvements and installation works for the pilot included functional rearrangements of the pilot offices, improvements of the pilot envelope (adding of thermal insulation, changing of the windows, fixing of motorized shadings), functional rearrangements of the machinery room and preparation for new equipment. Furthermore they involved installation of the renewable components on the facades, installation of mechanical equipment, electrical and supporting systems for heating and cooling, installation of energy efficient lighting in the offices and installation of the building management system (BMS) for the pilot. This all leads to the conclusion that special attention and a holistic approach with adaptable technical solutions are needed in all segments of the existing buildings refurbishment.

## CONCLUSIONS

At the pilot ZAG building a new concept for the retrofitting of office buildings together with two types of newly developed components is in the testing phase. Planned monitoring strategy for the retrofitted offices will enable the measurement of the energy consumption of all devices and equipment as well as of both indoor and outdoor conditions. Results will be used for the optimisation of high-rise building retrofitting, to reduce energy consumption and for the implementation of innovative technologies from the Cost Effective project.

This kind of demonstration of the technologies integrated into existing buildings contributes to the development, integration and demonstration of the newly developed concepts and components. It also shows that the refurbishment approach needs special attention and a holistic approach with adaptable technical solutions in all segments of existing buildings. The design phase has to be prepared very carefully to include different kinds of possible scenarios for effectively operating the refurbished building system.

## ACKNOWLEDGEMENTS

The research leading to these results has received funding from the European Community's Seventh Framework Programme under grant agreement No. 212206 which is highly appreciated. The information given in this publication does not necessarily represent the view of the European Commission (EC).

# Dragan Vuković, Nebojša Adžić, Montenegro

## The First Private Environmental and Energy-Efficient Building in Montenegro – A Case Study

Engineers Chamber of Montenegro

E-mail: [dragan.vukovic@greenhouse.co.me](mailto:dragan.vukovic@greenhouse.co.me) / [nebojsa.adzic@gmail.com](mailto:nebojsa.adzic@gmail.com)



### ABSTRACT

A house of the family Adzic is located in downtown Niksic, and is one of the few or, perhaps, the first new private construction facility in Montenegro that can also be classified as an environmental and energy-efficient building.

In the work it will be represented all of facilities and designing principles where are included in this project, that make it very attractiv and energy-efficiency.

Some of the them such as the concept of designing a square, compact form resulted in a reduction in heat loss through the outer layer of the object, or the heating of the facility is in the system of uses water from the well, and other of similar principles.

A house of the family Adzic is located in downtown Niksic, and is one of the few or, perhaps, the first new construction facility in Montenegro that can also be classified as an environmental and energy-efficient building.

Why do we say „the first“? Because in our country the term „energy efficiency“ is relatively new. One of the earliest documents in this area is „Strategy of energy efficiency in the state of Montenegro“ which is adopted in 2008. year. Law on energy efficiency was made official in 2010 year. In the other hand the Family house Adzic is designed in 2003 year, and finished in 2008 year.

Primary concept was based on the design of energy efficient and environmental friendly house. In the 2003 year it was very new and relatively unknown concept in the architectural design in Montenegro.

The number of floors of the house includes the basement, ground floor and the upper floor, with the division into daily activities on the ground floor, the night zone on the upper floor, and accessory rooms in the basement.

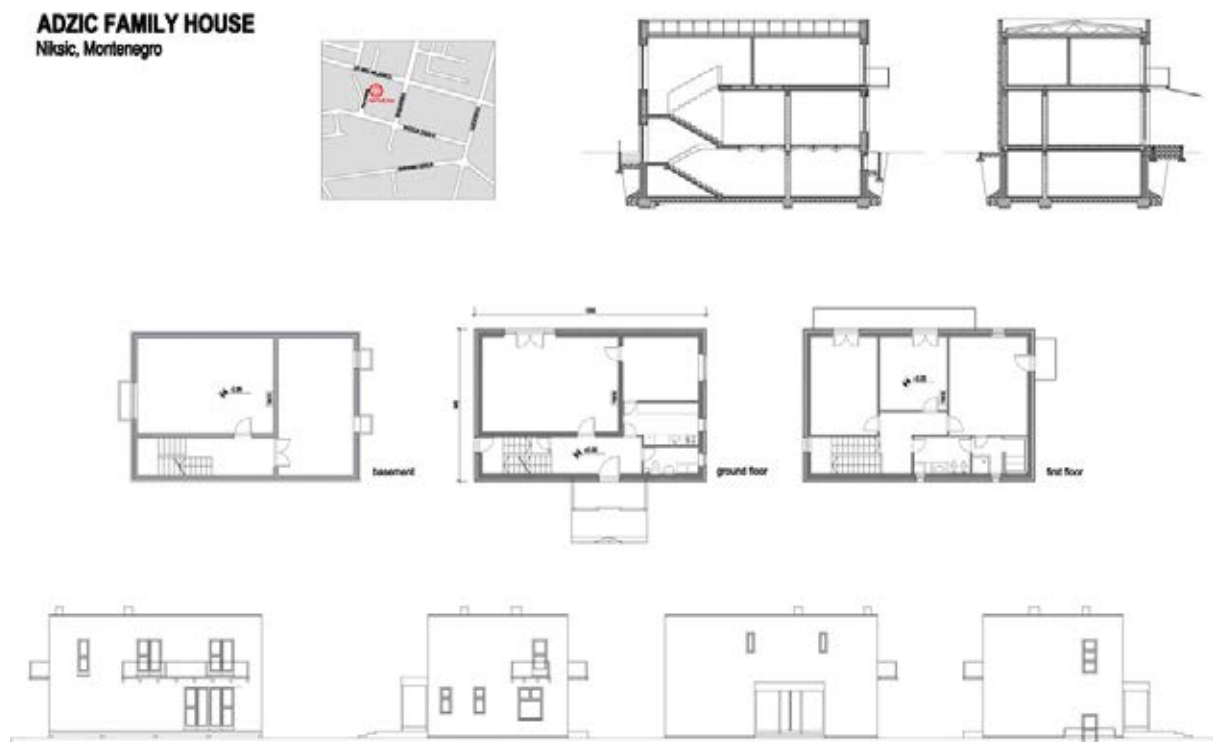



In general, we can say that this house is made of wood and bricks. Constructive walls are made of brick 25cm thick, with isolation of 8cm, and the facade covering of coniferous timber on the substructure, which forms an air facade with air layer of 5cm.



393

The ceiling between the ground floor and the upper floor is made of the glued laminated timber beams, visible in the interior of the living and dining rooms, whereas above the basement, the ceiling is "Prussian vault" type made of bricks, put together on steel "I" sections. The roof structure is made of the lattice wooden light roof trusses, with thermal insulation of 20 cm.



DRAGAN VUKOVIĆ, NEBOJŠA ADŽIĆ

For the purpose of energy efficiency, windows and doors are glazed with triple low-emission glasses.

The concept of designing a square, compact form resulted in a reduction in heat loss through the outer layer of the object (a ratio of layer surface and the facility volume  $A / V$  of 0.4 is achieved, bearing in mind that the optimal values are calculated under 0.8).



Heating of the facility is in the system of a heat pump that uses water from the well, with an average temperature about 10°C, being implemented through a system of wall heating and cooling of the Austrian firm "Variotherm", where pipes, through which hot/cold water flows, are installed along the constructive

walls being plastered with thermal mortar, thus having no visible fittings (cables, etc). Constructive walls made of solid brick are heat batteries and transmitters, whereas in summer temperature is lowered through them. It is a very cost-efficient heating and cooling system.

The simplicity of the external form is reflected in the interior, where all the rooms are separated but functionally related.

Overall impression of the facility position, located in the middle of the plot, surrounded by a coniferous forest of an adjacent parcel of a bank, and in the ambiance of a partly preserved atmosphere of Niksic's Gruda quarter, indicates with what care the form of the facility has been chosen, as well as altitude regulation and attitude towards the historical legacy as an autonomous whole.

**ADZIC FAMILY HOUSE**  
Niksic, Montenegro



# Dr. Frank Heinlein, Germany



395

FRANK HEINLEIN

## Making Sustainability Visible!

DGNB (German Sustainable Building Council)

E-mail: [Frank.Heinlein@WernerSobek.com](mailto:Frank.Heinlein@WernerSobek.com)

### ABSTRACT

Over recent years a public consensus has been reached as to the necessity of designing, building and managing our built environment in a sustainable way. Whereas there is a broad agreement on the objectives, there is still considerable debate on the question of how these objectives can be achieved - and how we can actually measure them. The DGNB certification system proposes a holistic view of sustainability in the built environment, offering a comprehensive tool to describe, analyse, and evaluate its quality. The presentation by Frank Heinlein gives a brief introduction into the basic philosophy underlying the system and explains its mode of operation.

## SUSTAINABLE BUILDINGS

The construction and real estate sectors are in a state of change: Energy efficiency, resource protection, residential and workplace health, value retention and risk mitigation are now in focus. General conditions and market interests are changing. Therefore, in the future buildings will be planned, built and operated differently, i.e. more sustainably. Sustainable building means to build intelligently: The focus is on a comprehensive quality concept that serves the building and real estate sectors, as well as society in general. Sustainable properties are beneficial to the environment, they conserve resources, they are comfortable and healthy for their users, and they fit optimally into their socio-cultural surroundings.

This article is an introduction to the DGNB certification system developed by the German Sustainable Building Council. The DGNB system supports planners and construction firms in the realization of sustainable buildings. It makes it possible to assess a building's overall performance. Along with precertification, the DGNB criteria can be used to identify efficient, inexpensive steps during the planning phase. Furthermore, the DGNB pre-certificate gives investors the confidence during the early planning stage that the building's performance targets can actually be reached once the building is completed.

### THE GERMAN CERTIFICATION SYSTEM

The DGNB certification system was developed by the German Sustainable Building Council. It supports planners and construction firms in the realization of sustainable buildings. At the same time it offers a precise definition of sustainability and makes it possible to perform an objective assessment of different buildings in different locations. Sustainability thus becomes measurable – and comparable.

The DGNB system assesses the building's overall performance, not individual actions. Building owners and planners therefore have the greatest possible leeway in reaching those targets. Innovative solutions are promoted. The system can be updated thanks to its flexibility. Moreover, it can easily be adapted to different technical, cultural, or climate conditions. Through a precertification during the planning process the DGNB criteria can be used to identify efficient, inexpensive steps helping to improve the building. Furthermore, the DGNB precertificate also gives investors the confidence during the early planning stage that the building's performance targets can actually be reached once the building is completed.

The DGNB system promotes integral building planning, thereby capping optimization potential for construction, operation, and the end-of-life phase. As a result, the risk of vacant buildings is also reduced. The award increases the chance of selling and renting since it demonstrates a building's holistic high quality to owners and users. Furthermore, the DGNB certificate signals greater quality and workmanship, increased user-friendliness, and improved re-rental ratios. The DGNB certificate offers the right usage profile for every type of building. Nonetheless, all buildings are evaluated on the same basis, which reduces training time for auditors and facilitates the application of the system.

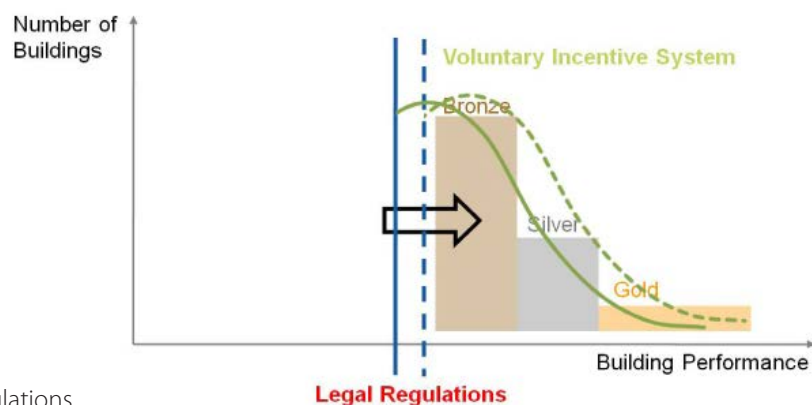

Copyright: DGNB

Figure 1: Certification in relation to legal regulations

## ADVANTAGES OF THE CERTIFICATE

- Active contribution to sustainability: The certificate demonstrates, in a quantifiable way, the positive effects of a building on the environment and on society.
- Cost and planning security: Precertifying a building during the planning process makes a substantial contribution to ensuring that the performance goals of a building can actually be reached at the time of completion. For example, it can help to reduce the energy consumption and costs during operation.
- Reduction of operational risk: The certification process promotes integral planning. This leads to more transparency and well-defined processes during planning and construction, opens up potentials for optimization, and minimizes the risks during construction, operation, refurbishments, and deconstruction.
- Praxis-oriented planning tool: The certificate was developed by practitioners for practitioners. It supports owners and designers in a goal-oriented way in developing sustainable buildings.
- Focus on the life cycle: The certificate is based on the life cycle of a building, which is indispensable for an evaluation of the sustainability.
- Made in Germany: The certificate is optimally adapted to the German and European building environment. This includes building codes and norms, as well as long-term market experience with energy efficient buildings etc.
- Marketing tool: The certificate serves as a communication tool for investors, owners, and users – it documents their commitment to sustainability. As a sign of quality, it supports export, and it enhances the attractiveness of the German real estate sector for investors.
- Comprehensive quality of a property: The certificate can enhance the chances for sale and rent. The certification makes the high quality of a building visible for owners and users alike.
- Performance is key: The German certificate evaluates the building's performance and not merely single measures. Owners and designers are given a large leeway to achieve the targets.
- More than "Green Building": The certificate far exceeds the ecologic aspects of "green building" by also equally including the economic performance, as well as socio-cultural and functional aspects of buildings.
- Flexibility: The certificate system is flexible and can be updated. It can easily be adapted to different technical, cultural and climate conditions.

## EVALUATION AREAS

The system's foundation was developed for the building type "New office and administrative buildings". On this basis, other usage profiles were developed for completely different types of buildings. As a second-generation certification system, the DGNB system features a very high level of flexibility. The foundation of the evaluation consists of a list of focal points developed by broad consensus and their criteria for sustainable building. Depending on the type of building to be evaluated, these criteria are weighted differently according to use-specific factors. Each usage profile – that is, each type of building – thus has its own weighting matrix and is optimally adapted to its specific use.

### The areas of evaluation are:

- Ecological quality
- Economic quality
- Socio-cultural and functional quality
- Technical quality
- Process quality
- Site quality



Copyright: DGNB

Figure 2: DGNB qualities

The six areas are weighted in the overall evaluation of the building according to importance. Economic quality, ecological quality, and socio-cultural, functional, and technical quality each make up 22.5 per cent of a building's total performance index, with process quality contributing 10 per cent. Quality of the location is not included in the total performance index but is evaluated separately.

Each of the six evaluation areas is divided into several criteria, such as energy demand, acoustic quality, or space demand. For each criterion, measurable target values are defined and measurement methods and documentation required for verification are clearly outlined. A maximum of ten points is given for each criterion. All criteria are weighted for the evaluation in two steps. Independent of the specific usage profile, each criterion has a weighting factor and can be counted in its broader category as many as three times. This weighting factor reflects a criterion's societal and political relevance and is the same for all types of use. A building's energy demand is thus more important than acoustic comfort. At the usage profile level, the system's methodology allows for further fine tuning. Here, weighting is determined according to a use-specific adaption factor that can increase a criterion's value by as much as threefold. This adaption factor can also be zero to remove criteria – indoor air quality does not matter for highway bridges, for example. Depending on the extent the requirements were fulfilled, the certificate is given in bronze, silver, or gold. The degree of fulfillment is given as a percent and a grade. With an overall degree of fulfillment of at least

- 50 %, a bronze certificate is awarded
- at least 65 %, silver
- at least 80 %, gold.

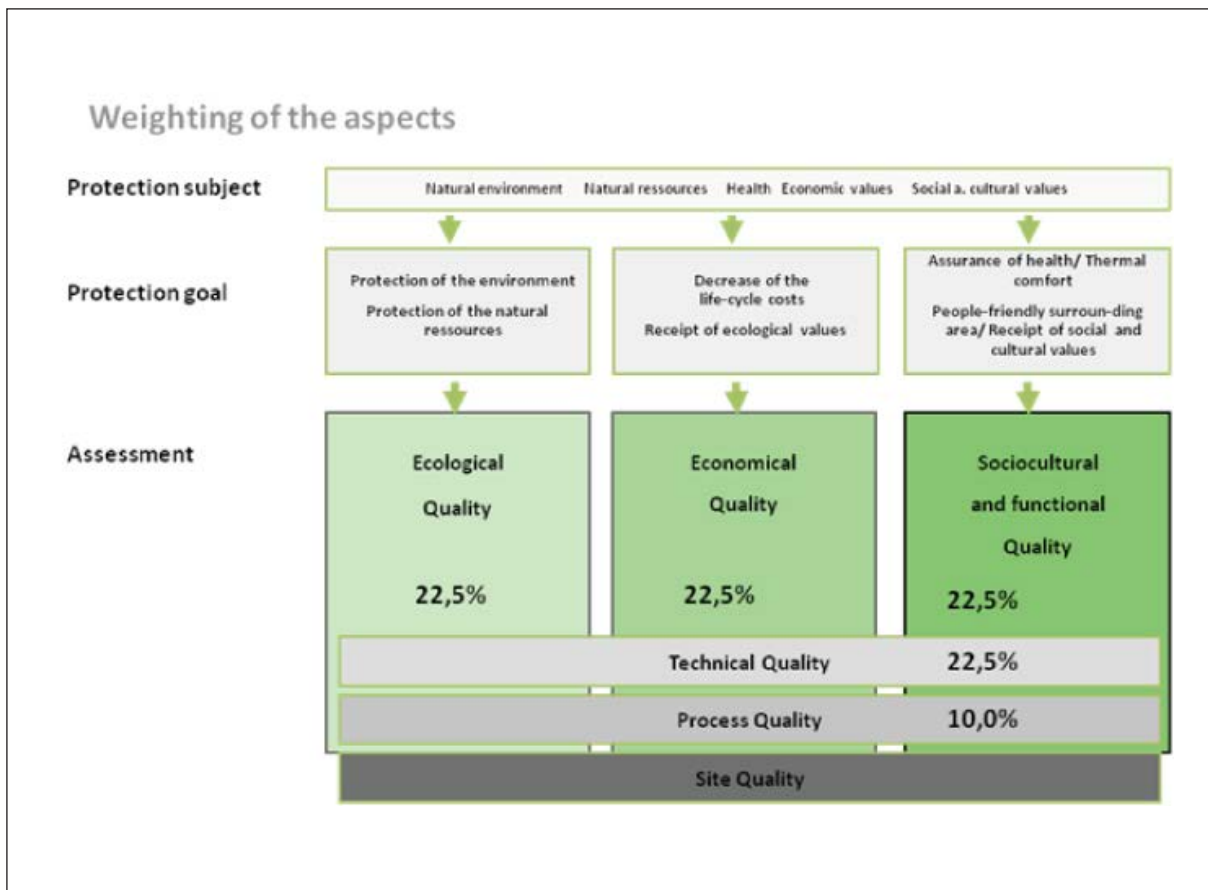

Copyright: DGNB

Figure 3: Weighting of the qualities

## AN OVERVIEW OF THE CRITERIA

In developing the certification system, six evaluation areas were defined that each contain various criteria representing the relevant areas of sustainable building. The version 2010 of “New office and administration buildings” the DGNB system, for example, is based on 48 of such criteria. Of those, 42 criteria describe building qualities, while six describe site quality, which is evaluated separately.

### • Ecological quality

- Global warming potential
- Ozone depletion potential
- Photochemical ozone creation potential
- Acidification potential
- Eutrophication potential
- Risks to the local environment
- Sustainable use of resources / wood
- Nonrenewable primary energy demand
- Total primary energy demand and proportion of renewable primary energy
- Drinking water demand and volume of waste water
- Space demand

### • Economic quality

- Building related life-cycle costs
- Suitability for third-party use

- **Socio-cultural and functional quality**

Thermal comfort in the winter  
 Thermal comfort in the summer  
 Indoor air hygiene  
 Acoustic comfort  
 Visual comfort  
 User control possibilities  
 Exterior quality as affected by the building  
 Safety and risk of hazardous incidents  
 Handicapped accessibility  
 Space efficiency  
 Suitability for conversion  
 Public access  
 Bicycling convenience  
 Assurance of design and urban development quality in a competition  
 Percent for art / Art on building

- **Technical quality**

Fire safety  
 Sound insulation  
 Quality of building envelope with regard to heat and humidity  
 Ease of building cleaning and maintenance  
 Ease of dismantling and recycling

- **Process quality**

Quality of project preparation  
 Integral planning  
 Optimization and complexity of planning method  
 Evidence of sustainable aspects in call for and awarding of tenders  
 Creation of conditions for optimal use and management  
 Construction site / construction process  
 Quality of contractors / prequalification  
 Quality assurance for construction  
 Commissioning

- **Site quality\***

Risks in the micro-environment  
 Condition in the micro-environment  
 Public image and condition state of site and neighborhood  
 Access to transportation  
 Proximity to use-specific facilities  
 Connections to public services

\* Accounted for separately; does not affect a building's overall appraisal.

## OPTIMIZING A BUILDING

Pre-certification makes it possible for investors and building owners to optimize their projects in the planning stage. The process creates a planning basis for sustainable construction and promotes an integral planning approach. Pre-certification is an excellent instrument to achieve planning goals, increases transparency, ensures clear planning and construction processes, improves risk management, and increases



a building's quality. For pre-certification, all main sustainability criteria must be defined as intentions or goals in an early planning step. Pre-certification therefore supports decision-making while also drawing the attention of those involved in construction to the requirements and is an important medium to communicate planning and construction objectives. In addition, pre-certification increases the likelihood that a building's planned performance goals will be achieved once it is completed. The process also makes it more likely that the completed building will receive certification without problems and the pre-certification's evaluation results will be confirmed. Pre-certification also provides advantages for marketing a building still being planned or built. Because of the system's high level of transparency and credibility, the building's future performance can be substantiated as early as the planning stage, increasing the building's chances of being rented or sold. Precertification can also increase security for financing projects. A certificate with evaluation results is awarded.

## INTERNATIONAL DEVELOPMENT

With the DGNB certification system, the DGNB has developed a second-generation certification system that sets international standards. One of the DGNB system's greatest strengths is its high level of flexibility. It can be adapted to both future technical and societal developments and regional particularities. These points can include climate, structural and legal requirements and cultural factors. Because of these features, the DGNB certification system is being internationalized very quickly. In June 2009, only half a year after the first DGNB certificates were awarded, TOWNTOWN Company Building of Vienna received the first certificate for a building outside of Germany. Other projects in Austria and Luxembourg have already been certified, and the number of inquiries from foreign investors is increasing as well as the number of actual certifications. Investors are interested in using the DGNB system's renown to document their properties' high quality standards.

The DGNB also has the goal of optimally adapting the certification system developed in Germany to requirements in other countries with the help of close partnerships with local non-profit and non-governmental organizations. It is very important to ensure the high quality of these adaptations. An international board of representatives of the DGNB and its partner organizations ensures the high quality standard worldwide. The Austrian Green Building Council (ÖGNI) was the first to adapt the system and awarded the first certificates for the Austrian version of the DGNB system in May 2010. Bulgaria, Denmark, and Switzerland have also founded their organizations and adapted the system to their specific needs. Other countries such as China, Brazil, Thailand and Russia will follow suit. Following the rapid internationalization of its highly flexible international certification system the DGNB is offering international training courses in Germany and other countries for DGNB international consultants / auditors in order to promote a common language on sustainability.

## THE DGNB AS AN INTERNATIONAL CERTIFICATION SYSTEM

The DGNB system was developed in order to provide a certification system based on international codes and standards making it easy to use in various countries while at the same time provide the high quality and transparency based on the DGNB philosophy. The system, available entirely in English, bases each of its criteria on corresponding European Standards.

The DGNB system is the first, and to date the only system worldwide in which the procedure for adaptation to different countries is an integral part of the system itself. This adaptation takes into account different climatic zones, associated cost-benchmarks, and a specific database for life-cycle assessment, within which the datasets for all European countries are made available. The DGNB system is therefore directly applicable within Europe – and often even beyond.

In addition to direct use, further adaptation of the system in the form of country-specific profiles is possible, following the establishment of a corresponding contract. Necessary requirements for such a contract are a sufficiently strong market interest as well as a qualified local working group. This working group has to comprise experts for the following seven areas: ecology, energy, building materials/pollutants, technical quality, socio-cultural quality, processes, location. The core of the individual criteria remains unchanged in the development of such a country-specific profile. The adaptation takes places primarily at the assessment method and evaluation criteria levels.

The DGNB system thus offers a comprehensive definition of sustainability in the building sector that can help to make a real step ahead towards a better built environment benefitting all of us – today, tomorrow, and beyond.

## Brian Kyle, Canada



403

### Green Building Rating Systems, Sustainability & Standardisation of Practise

World Federation of Engineering Organizations –  
Committee on Engineering and the Environment, Ottawa

E-mail: [brian.kyle@xtn-slam.com](mailto:brian.kyle@xtn-slam.com)

BRIAN KYLE

#### ABSTRACT

Partially in response to the Bruntland Commission's report, various green building rating systems have evolved over the past 25 years, all attempting to address a universal set of issues. As well, building practitioners and owners are faced with a plethora of eco-labelling brands that further confuse the comparison of sustainable procurement options. Numerous trade, design, research and professional associations have developed best practice documents to further "assist" and enhance sustainable performance in their respective domains. This presentation will examine these tools, their relative importance to greening and sustainable development as well as discussing relevant current standardisation activities for sustainable buildings.

## INTRODUCTION

With the publication of the report of The World Commission on Environment and Development in 1987 (commonly referred to as the Bruntland Commission Report) came a significant challenge with the call for sustainable development; defined as “development which meets the needs of the present generation without compromising the ability of future generations to meet their own needs.”

In the quarter century since that report, the core issues and requirements to make sustainable development a reality have not changed and there has been relatively little progress on universal satisfaction of sustainability objectives: economic development; social equity and justice; and environmental protection. Our survival depends upon proper custodianship of many of the world’s resources; some with finite supply. The world’s energy supply is diminishing coincidental with rising demand. Water is a finite resource and essential to life, yet its quality and distribution are not universally assured. Building materials are routinely directed to landfill, as if they were refuse and not worthy of further harvesting, reuse or recycling efforts.

Urbanisation has caused considerable pressure upon buildings to respond to the sustainability challenge. Concentrations of people and buildings yield greater demands upon natural resources and often present situations of heightened social inequity. Buildings and communities must be rethought with these issues in-mind.

The effects of a changing climate upon our capability to fulfill sustainability objectives must be considered. Energy consumption, migration as well as the use and availability of water and many other natural resources are directly linked to climatic loadings and changes that may occur.

The significance of the built environment upon our surroundings and interactions with people as well as their well-being is undeniable. This direct linkage to our environment and humanity should provide motivation for all engineers to do what is in their power to fulfill the sustainability goals, taking all reasonable action to assure that proper decisions are made, considering the desire to promote stable economic growth, to foster social progress and equality, and to conserve natural resources.

These issues are integrally linked and improved planning and actions are needed. The remainder of this paper examines potential role of green building practices and the available tools relative to greening and sustainable development.

## GREEN BUILDING RATING SYSTEMS

There are numerous green building rating systems in use and under development around the globe. They arose partially from the building industry’s relatively early recognition of the requirement to modify practices; changes driven by a combination of adverse economic impact due to high energy cost and a broad societal demand to improve the environmental performance of buildings. The vast majority of the systems rely upon the awarding of points in particular areas of concern related to environmental performance or human comfort. The particular performance issues considered, and their relative weighting, depends on the region or country of application. The following text briefly describes some of the more prominent green building rating systems and then provides some general discussion on the implications, advantages and pitfalls of their use.

### Leadership in Energy & Environmental Design (LEED)

The United States Green Building Council’s LEED (Leadership in Energy & Environmental Design) Green Building Rating System™ is a voluntary, consensus-based assessment system to support and certify successful green building design, construction and operations. Based upon the total point score achieved, following an independent review and an audit of selected credits, the building is assessed to one of four

levels of certification (certified, silver, gold or platinum). LEED may be applied to new and existing buildings, cores and shells, schools, commercial interiors and homes.

The administration of the testing and accreditation of individuals seeking LEED credentials is handled by an associated third party, Green Building Certification Institute (GBCI). GBCI provides six levels of accreditation, dependent upon the focus/interests of the individual. LEED has been adapted in other countries and regions; Canada, Latin America and India. In each of these cases, considerable modification was required to make the assessment criteria relevant to the local climates, jurisdictional and operational environments. (<http://www.usgbc.org/DisplayPage.aspx?CMSPageID=1988>)

### **Indian Green Building Council (IGBC) Rating Tool**

As an extension to established government guidelines, the Indian Green Building Council developed green building rating programs and tools to cover the commercial, residential, factory buildings and townships. The rating systems directly consider the available materials and technologies available. The IGBC also uses and promotes the application of LEED India. (<http://www.igbc.in/site/igbc/index.jsp>)

### **Green Rating for Integrated Habitat Assessment -(GRIHA)**

The Association for Development and Research of Sustainable Habitats, is mandated to promote development of buildings and habitats in India through GRIHA (Green Rating for Integrated Habitat Assessment), the National Rating System of India. GRIHA was developed jointly by The Energy and Resources Institute (TERI) and the Ministry of New and Renewable Energy, Government of India. It is a green building design evaluation system, and is suitable for various building types in different climatic zones of the country. (<http://www.grihaindia.org/>)

### **British Research Establishment's Environmental Assessment Method – (BREEAM)**

BREEAM can be used to assess the environmental performance of any type of building (new and existing) and a broad range of building schemes (standard versions) exist for common building types. Less common building types can be assessed against tailored criteria and schemes can be tailored for any country or region. Buildings outside the UK can be assessed with BREEAM International. BREEAM's accreditation and assessor training programs are provided in two day courses that are available at BRE for all construction and environmental professionals. Upon completing the training the candidates perform a test assessment, which if successful, will permit them to purchase a BREEAM licence. Assessor training in some non-domestic schemes/versions of BREEAM is also offered by BRE Global. ([www.breeam.org](http://www.breeam.org))

### **Green Globes**

The Green Globes system provides an interactive, online assessment protocol, rating system and guidance for green building design, operation and management that purports to be flexible, affordable, and to provide market recognition of a building's environmental attributes through third-party verification. Green Globes arose from BREEAM Canada for Existing Buildings, as published by the Canadian Standards Association (CSA) in 1996. The system became an online assessment and rating tool under the name Green Globes for Existing Buildings in 2000 and was later expanded to support new building design. It is now managed by the Green Building Initiative (GBI). Green Globes is accredited as a standards developer by the American National Standards Institute (ANSI) and the official Green Globes ANSI standard was published in 2010. (<http://www.greenglobes.com>)

### **l'Association HQE (Haute Qualité Environnementale)**

This assessment process, developed in France, involves a fairly flexible evaluation of buildings, new and existing as well as the site and fit-up considerations by evaluating the projects relative to 14 or 15 targets and the collection of points in each of these categories. The association has existed since 1996 and seems to have a reasonably level of support within segments of the French building industry although the engineering and architectural associations in France have expressed displeasure with the system.

(<http://assohqe.org/hqe/>, <http://www.architectes.org/developpement-durable/debats/l2019ordre-des-architectes-quitte-l-ordre-des-architectes-quitte-l-association-hqe>)

### **Valideo**

Valideo is a voluntary certification system that covers new, existing and renovated buildings. The Belgian system offers, what the developers refer to as, "a global approach", by considering all sustainability aspects for both the building and the construction organisations during all phases of the building's life-cycle. The system further incorporates accreditation and validation from third-party (associate) organisations. ([http://www.valideo.org/Public/valideo\\_menu.php?ID=8641](http://www.valideo.org/Public/valideo_menu.php?ID=8641))

### **Green Star**

Green Star is a voluntary environmental rating system that evaluates the environmental design and construction of buildings and communities. The system was developed by the Green Building Council Australia (GBCA). The Green Star suite of rating tools are customised for a variety of building types and occupancies ranging from educational and healthcare facilities through to office buildings new and existing. The evaluation criteria embodied in Green Star are particularly relevant to the Australian marketplace and environmental context. In addition to the rating system, Green Star also incorporates a project certification system, in which stars are awarded based upon point thresholds. Certification is coupled with a validation, by third-party Certified Assessors, of project documentation and credits (points). (<http://www.gbca.org.au/green-star/>)

### **Comprehensive Assessment System for Building Environmental Efficiency -(CASBEE)**

CASBEE is a joint effort of the Japan GreenBuild Council (JaGBC) and the Japan Sustainable Building Consortium (JSBC). Amongst the founding principles of CASBEE was that the assessment system should be as simple as possible, and applicable to a wide range of building types as well as specifically taking issues and problems peculiar to Japan and Asia into consideration. The associated tools have been in development since 2001 and offer assessment capabilities for new, existing and renovated buildings, detached homes, urban areas, cities and for property appraisal purposes. As well there are CASBEE tools for consideration of heat island and urban development. (<http://www.ibec.or.jp/CASBEE/english/index.htm>)

### **Deutsche Gesellschaft für Nachhaltiges Bauen (DGNB) System**

The German Sustainable Building Council (Deutsche Gesellschaft für Nachhaltiges Bauen) sees its primary role as identifying and advancing methods and solutions for sustainable buildings including the planning, construction and operation of buildings. The focus of the DGNB is on the certification of sustainable buildings. With their certification system, they help to optimize and document the quality of building projects. The DGNB certification analyses the product to the criteria of risks for the local environment as well as to the sustainable use of resources and requires that projects provide manufacturer-supplied life-cycle assessment of all building products based on Environmental Product Declarations, EPD (ISO 14025 and ISO 21930) and an estimate all life-cycle costs for building operations, including energy, water and cleaning costs. (<http://www.dgnb-international.com/international/>)

### **SBTool 2012 & SB Method**

The SBTool 2012 was developed by the International Initiative for a Sustainable Built Environment (iiSBE). The current 2012 version of the MS Excel spreadsheet is an update to previous versions of the software (GBTool later evolving to SBTool). iiSBE is an international non-profit organization intending to facilitate and promote the adoption of policies, methods and tools to accelerate a global sustainable built environment. Authorised third parties can use the SB Method to establish adapted SBTool versions as rating systems to suit their own regions and building types. The tool considers all phases of the building life-cycle. iiSBE claims that the SBTool is not limited by green building concerns and can be modified to consider as few as six criteria and also handle more than 100. Authorised third-parties may also be permitted to alter the weighting used by the tool. (<http://iisbe.org/>)

## Discussion / General observations

Green building rating systems have traditionally made little or no direct consideration of the social and economic development aspects of sustainability. There has been stronger potential to consider sustainability assessment criterion in later systems such as DGNB System and Green Star, and this capability is quickly evolving and being incorporated in other systems as well.

Very often green rating tools have been used to dictate design, as pre-design cook-books for greening, rather than as the post design assessment tools for which they were initially intended. In some instances this has drastically limited engineering creativity and can potentially led to inappropriate initial combinations of technologies being specified. The early years of applying rating systems inevitably led to horror stories based on “point-hunting” and the inequitable allotment of points or credits (e.g.; the selection of bike stands for a building rather than high efficiency glazing [due to the disproportionateness of points versus investment ]).

However, the quest to be green has led to heightened environmental performance of building products and systems, the development of innovative technologies and significant reductions in unit energy consumption. Some of that success is undoubtedly attributable to these rating systems.

Assessment of greenness via the rating tools has traditionally been dominated by energy related aspects (efficiency and consumption). This trend will continue and will serve to support a primary marketing thrust of green buildings -energy savings. The promise that green buildings will have higher energy performance pleases building owners and operators on two distinct levels; an altruistic motivation to be environmentally friendly and the direct economic benefit of using less energy.

Historically the rating systems have often lacked follow-up and in-use verification that the buildings are operating (or can operate) as intended in the initial design was often not performed.

Further to this, two studies of a population of green buildings illustrate that while the overall population of green buildings was likely to have a reduced energy footprint, it could not be stated that a green building would necessarily have a better energy performance than a conventionally design and constructed building. In 2008 Turner and Frankel [1] used a data set of 121 LEED certified buildings to compare their design-stage modeled energy use, with average national Energy Use Intensity (EUI) information. Of those buildings 30% were performing significantly better than their design-stage models and 25% performed statistically worse than projected. That data was re-examined in 2009 by Newsham et al [2] who attempted to improve on the methodology in several ways. Results indicate that LEED buildings on average performed 18%–39% better than their conventional counterparts. However, 28%–35% of LEED buildings used more energy per floor area than their individually matched counterparts. In addition, there was no significant correlation between LEED certification level, the energy credits received , their measured energy performance, or percent energy saved over the baseline counterpart.

Many of the green building rating and certification system are vigorously promoting the market advantage of their product; typically citing benefits to owners and tenants such as improved air and lighting quality, reduced energy consumption, generally reduced environmental burden and an overall greater occupant satisfaction with their surroundings .As well, most green building advocates profess that green buildings will have better long-term economic performance than their non-green counterparts. While there is some evidence that green buildings may garner higher rents (and lower vacancy rates) in some markets [3, 4,5] and that green buildings have caught the imaginations of the general public, there has not been a clear identification of the key element of the “marketing” advantage.

A recent study by Leaman and Bordass [6] suggests that the key to the retention of green clients may be vested in a sense of loyalty to the greening concept as opposed an overwhelming satisfaction with the green surroundings. That study revealed generally that users are more tolerant of flaws in green buildings.

The authors noted that green buildings got better client satisfaction scores for summary variables such as “comfort overall” or “lighting overall” and that the distinction of the favourable responses was reduced as these were divided into components. The study further concluded that green buildings often repeat past mistakes by creating unneeded and wasteful complexity and that green buildings are often employ highly integrated design features that cause them to be more ‘fragile’ in their performance; everything must work well together. The authors also observed that it becomes much harder to resolve conflicting requirements in larger buildings and surmised that smaller green buildings are often more successful than larger ones for this reason.

### **Eco-labelling**

Eco-labelling is intended to provide a level of assurance that environmental concerns have been adequately considered in the material acquisition, manufacturing and delivery of a given product. As well, some labelling systems may suggest particular life-cycle environmental implications inherent in a given product. In many markets there has been significant inconsistency in the methods used to determination environmental impacts and the potential for greenwash has caused some construction professionals to be leery of eco-labels. Some energy related labelling regimes falling under government mandated scrutiny (e.g. EnerGuide [Canada], ENERGY STAR [USA] and ENER-EcoDesign [EU]) have had wide acceptance and the validity of their sustainability assertions are generally not challenged. Other construction related systems that have had success adhere to strict documentation and assessment protocols and are diligent in the processes for approved use of their logos. Even with rigorous rules and compliance to the protocols the forest industry has two primary competing international eco-labels (Forest Stewardship Council [FSC] and the Programme for the Endorsement of Forest Certification [PEFC]).

An internet eco-labelling index page provides some indication of the diversity of eco-labels that exist ([http://www.ecolabelindex.com/ecolabels/?st=category,building\\_products](http://www.ecolabelindex.com/ecolabels/?st=category,building_products)); identifying over one hundred eco-brands related to building-products. These marks are associated with various facets of construction and the performance of the built environment.

### **Domain specific concerns, studies and best practices**

Energy use, and methods to reduce or improve the efficiency of that use, has been a long-term quest. The potential double-edged benefit of being green while reducing costs has heightened the desire to be energy efficient. Buildings account for about 35% of all energy consumption globally and a significant share of greenhouse gas emissions. Building energy codes help ensure that new buildings use energy efficiently, and this can reduce building energy use by 50% or more compared to buildings designed without energy efficiency in mind. This is important because buildings typically have long service lives, and it is much less expensive and time-consuming to design for energy efficiency than to retrofit a building later.

### **IEA**

The International Energy Agency (IEA) was established in November 1974 within the framework of the Organisation for Economic Co-operation and Development (OECD) to implement an international energy program. The IEA carries out a comprehensive energy co-operation program amongst the OECD’s thirty member countries. Amongst the basic aims of the IEA are the desires to improve the world’s energy supply and demand structure by developing alternative energy sources and increasing the efficiency of energy use and to promote international collaboration on energy technology.

Significant work by the various committees of the IEA has produced numerous documents that are relevant to sustainability of buildings and their operations. The committee on Energy Conservation in Buildings and Community Systems (ECBCS, <http://www.ecbcs.org/>) conducts research and development activities toward near-zero energy and carbon emissions in the built environment, focusing on integration of energy-efficient and sustainable technologies. Annex 46 of ECBCS has produced a Holistic Assessment Tool-Kit on Energy Efficient Retrofit Measures for Government Buildings (EnERGo). This document is focused on altering the decision-making processes for energy retrofitting of Government non-residential buildings, The tool-kit contains a list of operations driven Energy Conservation Measures and other guidance.



## CIB

The International Council for Research and Innovation in Building and Construction (CIB), established in 1953, is a world-wide network of over 5000 experts and 500 member organisations with a research, university, industry or government background, who collectively are active in all aspects of research and innovation for building and construction. The scope of CIB covers the technical, economic, environmental, organizational and other aspects of the built environment during all stages of its life cycle, addressing all steps in the process of basic and applied research, documentation and transfer of the research results, and the implementation and actual application of them. Virtually all of the CIB commissions are explicitly addressing sustainability concerns and, in some cases, have been doing so for an extended period. One example of this is the CIB Commission W083 Roofing Materials and Systems, which in 2001 published a report, entitled *Towards Sustainable Roofing* that contains a list of basic tenets to achieve sustainable roofing practice (<http://cibworld.xs4all.nl/dl/publications/Publi271.pdf>).

## Standardisation efforts

### ASHRAE

The American Society of Heating, Refrigerating and Air Conditioning Engineers (ASHRAE), founded in 1894, has more than 50,000 members worldwide focusing their activities on building systems, energy efficiency, indoor air quality, refrigeration and sustainability within the industry. ASHRAE conducts and funds research, standards writing, publishing and continuing education. Since its initial publishing in 1999, the ASHRAE 90.1, *Energy Standard for Buildings Except Low-Rise Residential Buildings* has been an international benchmark for building energy performance. Of current relevance are the ASHRAE Standard 189.1, *Standard for the Design of High-Performance, Green Buildings Except Low-Rise Residential Buildings* (<http://www.ashrae.org/resources--publications/bookstore/standard-189-1>), published jointly with the USGBC in 2010, and the *Green Guide* 3<sup>rd</sup> edition (<http://www.ashrae.org/greenguide>). The *Green Guide* is a step-by-step manual that covers the entire building life cycle, includes specific measures for improving sustainability as well as case studies, Green Tips, checklists, and other practical information.

### ASTM International

ASTM International, formerly known as the American Society for Testing and Materials (ASTM), develops international voluntary consensus standards and has in the order of 12,000 standards currently in use around the world. ASTM garners support and contributions from its 30,000+ members in 135 countries. ASTM states that 151 of their specifications, test methods, and practices address sustainability or aspects of sustainability relative to building, including sustainable design, construction, and operation of buildings. The relevant standards cover building product sustainability assessment, green roofing systems, water reclamation, environmental life cycle assessment and more. A key document recently published by ASTM is E2432-11, *Standard Guide for General Principles of Sustainability Relative to Buildings*. This guide distinguishes between ideal sustainability and applied sustainability. This guide recognizes that, in applying sustainability principles to buildings, decision makers must often balance opportunities and challenges associated with each of the general goals, environmental, economic, and social. This guide addresses buildings individually and collectively. The general principles identified in this guide are applicable to all scales of building projects, including: interior spaces, individual buildings and groups of buildings, infrastructure systems, and land use. As well, the general principles identified are applicable to all life-cycle stages of a building and its components (material extraction through to deconstruction, and waste disposal). This guide does not provide guidance on the implementation of the general principles and does not provide direction on weighting of the principles realising that multiple levels of professional judgment will be required.

### CSA Group

The Canadian Standards Association Group (CSA Group) is one of Canada's primary accredited standard writing bodies. Many of the standards developed by CSA Group are explicitly referenced in the building codes within Canada and as such fulfillment of their stipulations becomes legally binding. The CSA TC on Sustainable Construction Practices (A135TC) has published two documents that are particularly relevant to sustainability of buildings. They are:

- CSA Z782-06 *Guideline for design for disassembly and adaptability in buildings*, is a voluntary guidance document that provides a framework for reducing building construction waste at the design phase; and
- CSA Z783-12, *Deconstruction of buildings and their related parts*, specifies minimum requirements for processes and procedures related to the deconstruction of buildings. It is intended to be used by contractors, consultants, designers, building owners, regulators, and material supply and value chain organizations involved in deconstruction of a building that is at the end of its service life or undergoing renovations or alterations.

Design for disassembly and adaptability (DfD/A), described in the Z782, is an approach to sustainability that can reduce the environmental footprint of the building industry by reducing waste generation, improving building longevity, and reducing energy consumption by intelligent design. The disassembly component of DfD/A seeks to address this principle by making it easier to take products and assemblies apart in order to reuse or recycle materials. The adaptability component focuses on enabling the building to be used beyond its original intent, by readily accommodating substantial change within an existing physical asset. CSA Z782-06 includes a conceptual framework for DfD/A, specific principles and annexes. The Guideline also reviews quantifiable metrics for each DfD/A principle that, after further development, can be assembled into a matrix or checklist to guide users in the direction of disassembly criteria design.

### CEN

The European Committee for Standardization (CEN) has existed since the early 1960's but was officially created as an international non-profit association in October 1975. The mission of CEN is to foster the European economy in global trading, the welfare of European citizens and the environment. CEN 's 33 National Members contribute to the development of voluntary European Standards (ENs). An EN, once approved, becomes the de facto national standard in each member country.

The CEN Technical Committee 350 on Sustainability of construction works ( TC 350) is tasked to develop voluntary standards for the assessment of the sustainability of new and existing construction works as well as for standards on environmental product declaration of construction products. The standards developed by TC350 are generally applicable to the assessment of integrated life cycle performance of buildings including a harmonized methodology for assessment of environmental performance of buildings and life cycle cost performance of buildings as well as the quantifiable performance aspects of health and comfort of buildings.

Documents published by the CEN TC350 are as follows:

- EN 15643-1:2010 Sustainability of construction works -Sustainability assessment of buildings Part 1: General framework;
- EN 15643-2:2011 -Sustainability of construction works -Assessment of buildings -Part 2: Framework for the assessment of environmental performance;
- EN 15643-3:2012 Sustainability of construction works -Assessment of buildings -Part 3: Framework for the assessment of social performance;
- EN 15643-4:2012 -Sustainability of construction works -Assessment of buildings -Part 4: Framework for the assessment of economic performance;
- CEN/TR 15941:2010 -Sustainability of construction works -Environmental product declarations Methodology for selection and use of generic data;
- EN 15978:2011 -Sustainability of construction works -Assessment of environmental performance of buildings -Calculation method; and
- EN 15804:2012 -Sustainability of construction works -Environmental product declarations -Core rules for the product category of construction products.;

### ISO

The International Organisation for Standardisation (ISO) was founded with the intent of minimising international disputes and to harmonise the standards-setting activities world-wide. ISO has several

Technical Committees (TCs) and Subcommittees (SCs) that are related to sustainability and environmental concerns. The following section describes the activities and publications of a few ISO organisations that impact directly on these domains.

### Technical Management Board

In 2010, the ISO Technical Management Board (TMB) published a document that attempted, in part, to address one of the often overlooked, yet key, aspects of sustainability, social progress and equality. The document, ISO 26000:2010, *Guidance on social responsibility*, is intended to heighten contribution to sustainable development and to encourage organisations to exceed legal expectations; an essential part of their social responsibility. It attempts to promote common understanding in the field of social responsibility, and to complement existing instruments and initiatives.

### Technical Committee 205

TC 205, *Building environmental design* develops standards and guidance relative to the physical performance of the built environment, considering energy efficiency, building automated control systems and air quality. Of the document under the direction of TC205, ISO 23045:2008 *Building environment design --Guidelines to assess energy efficiency of new buildings* is the most significant to the topic at hand, providing guidance related to energy efficiency in new buildings. The objectives of the document are to assist designers and practitioners when collecting and providing the useful data that are required at different stages of the design process and to fulfil the definitions of the building as prepared by building designers.

### Technical Committee 207

TC 207 on *Environmental Management* is responsible for the development of standards and guidance for uniform consideration of environmental aspects and impacts. The work of TC207 Subcommittee 3, *Environmental labelling* and TC207 Subcommittee 5, *Life cycle assessment* is significant to building in that they provide overarching frameworks upon which specific buildings and construction related standards are developed.

TC207/SC3 is responsible for the development and maintenance of standards associated with labelling of products. Two standards of this SC are specifically relevant to the built environment They are:

- ISO 14024:1999, Environmental labels and declarations --Type I environmental labelling -Principles and procedures; and
- ISO 14025:2006, Environmental labels and declarations --Type III environmental declarations -

Principles and procedures, TC207/SC5 handles the standardisation activities touching on life-cycle assessment practices. The most significant of the documents produced by this subcommittee, relative to buildings, is:

- ISO 14040:2006, Environmental management --Life cycle assessment --Principles and framework.

### Technical Committee 59

Standards particular to buildings sustainability, are being prepared by TC59 *Buildings and civil engineering works*. The work of TC59 Subcommittee 14 *Design Life* and TC59 Subcommittee 17 *Sustainability in buildings and civil engineering works* is of note,

TC59/SC14 is tasked with the preparation of standards on the service life planning of buildings, touching on the prediction of service life (planned and remaining), life-cycle cost and appropriate methods to assess environmental impact over the buildings service life. Relevant documents published by TC59/SC14 include:

- ISO 15686-2:2012, Buildings and constructed assets --Service life planning --Part 2: Service life prediction procedures;
- ISO 15686-5:2008, Buildings and constructed assets --Service-life planning --Part 5: Life-cycle costing; and
- ISO 15686-6:2004, Buildings and constructed assets --Service life planning --Part 6: Procedures for considering environmental impacts.

ISO 15686-6:2004 describes how to assess, at the design stage, the potential environmental impacts of alternative designs of a constructed asset. It identifies the interface between environmental life cycle assessment and service life planning

TC59/SC17 develops framework and guidance documents to assess sustainability aspects of built works. Much of the initial activity of the subcommittee was focused on buildings. Many of the key players on this subcommittee are also active in the CEN TC350 and there has been a very close and beneficial liaison between these committees.

The following standards, relevant to buildings, have been published by TC 59/SC 17:

- ISO 15392:2008, Sustainability in building construction --General principles ;
- ISO/TS 21929-1:2011, Sustainability in building construction --Sustainability indicators --Part 1:

Framework for the development of indicators and a core set of indicators for buildings;

- ISO 21930:2007, Sustainability in building construction --Environmental declaration of building products; and
- ISO/TS 21931-1:2010, Sustainability in building construction --Framework for methods of

assessment of the environmental performance of construction works --Part 1: Buildings The latter of these documents, ISO 21931-1:2010, is a technical specification and provides a general framework for improving the quality and comparability of methods for assessing the environmental performance of buildings and their related external works. It identifies and describes issues to be taken into account in the use and development of methods of assessment of the environmental performance for new or existing buildings in their design, construction, operation, maintenance and refurbishment, and in the deconstruction stages. In addition to maintaining their existing documents, SC 17 is currently working on the development carbon metrics for buildings and guidelines for the application of the general principles on sustainability,

### New work items

Current plans for new ISO activities in the sustainability and sustainable buildings realms include the development of standards on:

- the design for disassembly and adaptability (using the CSA Z782-06 as a seed document);
- smart urban infrastructure metrics;; and
- sustainable development in communities.

## CONCLUSIONS AND RECOMMENDATIONS

Various green building rating systems exist; all having specific advantages and benefits but the most valuable and desirable assessment system is one that satisfies, or can be modified for, local needs. Adaptation is an ultimate goal of being "green" and climate change is pushing the adaptation agenda. Interactions between sustainability goals are recognised and enabling building technologies, knowledge and tools are at-the-ready. Now is the time to take action and make sustainability a reality.

## REFERENCES

- [1] C. Turner, M. Frankel, *Energy performance of LEED for new construction buildings*, New Buildings Institute, 2008
- [2] G. R. Newsham, S. Mancini, and B. J. Birt, "Do LEED-certified buildings save energy? Yes, but...," *Energy and Buildings* 41 (2009) 897-905.
- [3] Morris, Peter and Matthiessen, Lisa. "The Cost of Green Revisited," Davis Langdon, Inc., 2007.
- [4] Royal Institute of Chartered Surveyors. "Green Value," London and Vancouver: RICS, 2005.
- [5] T. W. Chappell, C. Corps, and B. Smith, "High Performance Green Building: What's it Worth? Investigating the Market Value of High Performance Green Buildings", Cascadia Region Green Building Council, 2009
- [6] Adrian Leaman & Bill Bordass (2007): Are users more tolerant of 'green' buildings?, *Building Research & Information*, 35:6, 662-673



## Alexander Lehmden, Austria

### The road to the “Nearly Zero Energy Building”

Wienerberger AG

E-mail: [Alexander.Lehmden@wienerberger.com](mailto:Alexander.Lehmden@wienerberger.com)

#### ABSTRACT

In the Lower Austrian city of Zwettl the first e4 BRICKHOUSE 2020 – a model house for sustainable construction with bricks – has been under construction since July 2011 together with a private investor. The house was energetically planned and optimized by the Austrian Institute of Technology. The e4 BRICKHOUSE 2020 is a nearly zero energy house that already meets the requirements of the EU's energy performance of buildings directive for 2020 (Directive 2010/31/EU).

*“nearly zero-energy building” means a building that has a very high energy performance. The nearly zero or very low amount of energy required should be covered to a very significant extent by energy from renewable sources, including energy from renewable sources produced on-site or nearby;*

DIRECTIVE OF THE EUROPEAN PARLIAMENT AND OF THE COUNCIL on the energy performance of buildings

The house of the future will be more than simply a place to live. It must meet more stringent legal requirements, as well as also the growing demands of its residents. The e4 BRICKHOUSE 2020 – a model home in the Lower Austrian Waldviertel district – will meet 100% of energy requirements through renewable energy sources. Over a 12-month period, the single family house produces more energy than it uses. It has a positive CO<sub>2</sub> and primary energy balance. And it is affordable.



In the Lower Austrian city of Zwettl the first e4 BRICKHOUSE 2020 – a model house for sustainable construction with bricks – has been under construction since July 2011 together with a private investor. The e4 BRICKHOUSE 2020 is a nearly zero energy house that already meets the requirements of the EU's energy performance of buildings directive for 2020 (Directive 2010/31/EU). The Wienerberger e4 BRICKHOUSE concept stands for: Energy, Environment, Emotion & Health and Economy. The newest brick generation, the POROTHERM system, keeps energy demand low throughout the entire year. You can follow the project at [www.facebook.com/e4.BRICKHOUSE](http://www.facebook.com/e4.BRICKHOUSE).

*“nearly zero-energy building” means a building that has a very high energy performance. The nearly zero or very low amount of energy required should be covered to a very significant extent by energy from renewable sources, including energy from renewable sources produced on-site or nearby;*

*DIRECTIVE OF THE EUROPEAN PARLIAMENT AND OF THE COUNCIL on the energy performance of buildings*

The EU Commission has already issued relevant directives such as the energy performance of buildings directive mentioned above which requires all new houses to meet nearly zero energy standards beginning in 2020. A nearly zero energy house is a building that covers most of its low energy requirements with locally available, renewable energy sources. That means the CO<sub>2</sub> emissions of buildings will be as low as possible. Nearly zero energy buildings not only have low energy requirements for heating, but also low primary energy usage – two developments that will help to reduce emissions and energy consumption in the building sector. With the e<sup>4</sup> BRICKHOUSE concept, Wienerberger currently exceeds the standards defined by this EU directive.



The house of the future will be more than simply a place to live. It must meet more stringent legal requirements, as well as also the growing demands of its residents. With the e<sup>4</sup> BRICKHOUSE concept, Wienerberger makes future-oriented construction possible today. The e<sup>4</sup> BRICKHOUSE 2020 – a model home in the Lower Austrian Waldviertel district – will meet 100% of energy requirements through renewable energy sources. Over a 12-month period, the single family house produces more energy than it uses. It has a positive CO<sub>2</sub> and primary energy balance. And it is affordable.

This concept meets the growing demands of many homeowners to make a contribution to climate protection with the construction of their own house. The e<sup>4</sup> BRICKHOUSE concept makes healthy, energy-efficient and, at the same time, affordable construction possible. At slightly more than EUR 1,700 per m<sup>2</sup> including tax, construction costs reflect the middle of the comparative range in Austria. Additionally, a house should not lead to high electricity and heating costs for its owners. The total energy costs for the e<sup>4</sup> BRICKHOUSE 2020 are estimated at roughly EUR 700 per year. Naturally, there should also be sufficient opportunities for the creative design of living areas. The house of the future must be individual and turnkey at the same time.



The first e<sup>4</sup> BRICKHOUSE 2020 represents a pioneer object. This house represents the next logical step after low-energy and passive energy houses. In accordance with the EU targets the model house in Zwettl will have a positive CO<sub>2</sub> and primary energy balance. This will be made possible, above all, by the use of renewable energy sources. For example, a photovoltaic aggregate will produce enough electricity for an entire year. The sun will also be used to provide hot water and heating energy. The heart of the house is formed by solar collectors, which heat a 9,500 liter water tank to store the energy. This will allow us to meet 60% of the heating energy demand with solar energy.

In order to make the visions for the e<sup>4</sup> BRICKHOUSE 2020 become reality, an independent research institution is involved in the planning and future monitoring after the building of the house is finished this summer. The AIT Austrian Institute of Technology will carry out exact measurements of the model house for two years after completion. AIT plans to collect reliable information on energy consumption, on the electricity and heating supplied by the energy systems and on factors related to thermal comfort such as the temperature of the interior rooms and wall surfaces as well as the interior humidity.

<b>Facts &amp; Figures on the e<sup>4</sup> BRICKHOUSE 2020</b>	
<b>Site area</b>	964.00 m <sup>2</sup>
<b>Built-up area</b>	194.44 m <sup>2</sup>
<b>Floor space a on ground floor and first floor</b>	202.80 m <sup>2</sup>
<b>Floor space in roof story and side wing</b>	125.41 m <sup>2</sup>
<b>Heated gross floor space</b>	277.00 m <sup>2</sup>
<b>Start of construction / completion</b>	Summer 2011 / Summer 2012
<b>Energy demand for Heating / year</b>	39.10 kWh/m <sup>2</sup> /a
<b>Total energy demand / year</b>	71.38 kWh/m <sup>2</sup> /a
<b>Total energy production* / year</b>	73.78 kWh/m <sup>2</sup> /a
<b>Primary energy demand* / year</b>	-3.57 kWh/m <sup>2</sup> /a
<b>CO<sub>2</sub> emissions / year</b>	-0.64 kg CO <sub>2</sub> /m <sup>2</sup> /a
<b>Construction costs incl. VAT</b>	€ 1,722.00 / m <sup>2</sup>

\* Based on the share of non-renewable energy of the respective primary energy demand.



# Martin Feder, United Kingdom



## Integrated Solutions Designed for High Performance and Sustained Results

Director, EMEA SmartStruxure Launch

E-mail: [Martin.Feder@schneider-electric.com](mailto:Martin.Feder@schneider-electric.com)

### ABSTRACT

Reducing energy consumption in buildings by up to 30% using multilingual Building Management System (BMS) StruxureWare, with the following architectures as native protocols: BACnet, LonWorks and Modbus. StruxureWare system allows to combine the management of power, data centers, process and controls, building management and security onto one seamless system that is IT and user friendly and provides out-of-the-box reporting to help right decision-making.

## CHALLENGES: DO MORE WITH LESS

The demand for green buildings is accelerating rapidly based on several factors. These include regulatory pressures around the world; shareholder and public demands for socially sustainable business practices; increasing demand for energy; economic, demographic, and industrial growth; and rising energy prices.

Green directives driving major change include the net-zero energy regulations in Europe, the CRC Energy Efficiency Scheme in the UK, and China's mandate to reduce CO<sub>2</sub> emissions by 40% by 2020 (below 2005 levels). New buildings standards and certifications, such as ISO 50001, the China Green Buildings Label, and the shift of LEED and BREEAM to include certifications for operational performance of existing buildings are also having a significant impact on the built environment.

In addition to these factors, business leaders are under pressure to achieve better business outcomes—like improved stock performance, increased asset value and rental rates, increased occupancy and tenant retention rates, improved employee productivity and well-being, and fulfilment of corporate social responsibility goals.

Whether building a new building or operating/retrofitting an existing one, asset managers, property developers, property managers, and occupants are under mounting pressure to achieve higher performance with lower capital and operating costs. At the same time, they are also complying with strict regulations, creating sustainability strategies, adopting evolving technologies, and striving to sustain increased business productivity.

As these challenges mount, forward-thinking companies will benefit from partnering with technology providers that offer comprehensive, integrated, scalable solutions that enable buildings to actively contribute to the triple bottom line of people, profit, and planet.

## SOLUTION: AN INTEGRATED GREEN BUILDING INFRASTRUCTURE

The traditional bid-spec construction approach leads to siloed systems with redundant cabling, hardware, and software, and the absence of data sharing. This results in wasted resources—energy, productivity, time, and money.

Schneider Electric's solution is the foundation for designing a world-class green building or an enterprise-wide portfolio. This leads to a host of benefits, as seen in Figure 1.

Our integrated infrastructure connects and enables communication between the key processes of the building, the owner, the facility manager, and the occupants:

An optimized, integrated system enables you to maximize your property portfolio's green value by creating high performance green buildings that are in high demand today. With this strategy, you can protect asset value, command higher rental rates, and increase occupancy and tenant retention rates. Improving occupant satisfaction leads to increased productivity – a factor that has significant impact on any organization's bottom line.

By integrating building infrastructure systems and processes, you can reduce total life cycle costs, another important factor in developing green value. Our integrated solutions can reduce your energy costs by up to 30% or more if renewable energy sources are used. This frees up capital for strategic investment and expansion. Convergence also allows you to save 25% on capital expenses by reducing cabling, installation, and commissioning costs associated with siloed building systems.



So what does a green building infrastructure look like? Figure 2 details the numerous services, systems, and applications within the facility or portfolio that can be connected to an integrated infrastructure.

Instead of demarcations between each network, there is seamless integration and full interoperability over an open protocol network. Having a common network ensures flexibility and scalability, allowing for changes, as well as the integration of emerging and future technology. It also provides a single point of monitoring, control, and maintenance, with fewer software programs to manage and troubleshoot.

### Building processes

- Control of indoor conditions: temperature, light level, humidity, air flow, air quality
- Sunblind control
- Energy management
- Metering and monitoring of Water, Air, Gas, Electricity, and Steam (WAGES)
- Renewable energy management
- Electric car charging
- Access control
- Video surveillance
- Fire safety
- Intrusion detection
- Data centre and IT room management
- Intelligent, interactive occupant and staff dashboards to encourage energy efficiency
- Electrical switchgear Occupant processes
- IP/network management system
- Room booking system
- Desk sharing system
- Facility management system
- Maintenance management system
- Property management system
- Cisco EnergyWise



Figure 1. Triple bottom line benefits of high performance green buildings

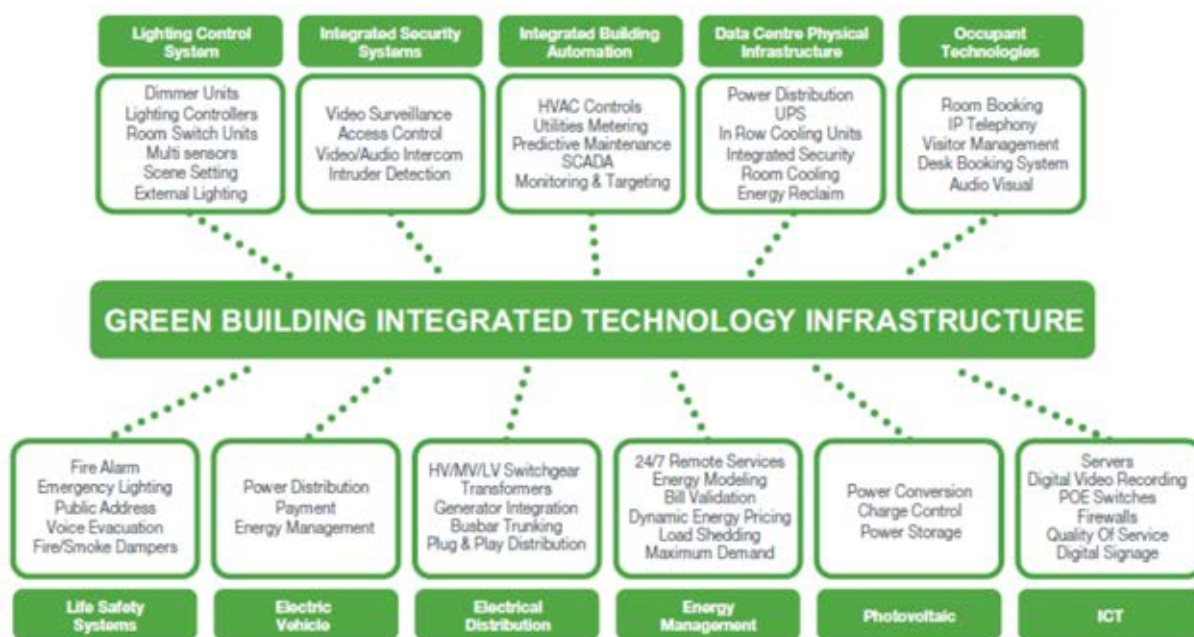

Figure 2. Systems and services connected to green building integrated technology infrastructure

## ECOSTRUXURE FOR GREEN BUILDINGS

We call our integrated infrastructure solution EcoStruxure™ system architecture. Our EcoStruxure solution for green buildings delivers reliable integration between building infrastructure systems, services, and applications. This improves asset value, rental value and financial performance (profit), minimizes environmental impact (planet) and creates safer, healthier places for work and play (people).

An EcoStruxure system architecture for green buildings enables the integration of five key domains of your enterprise –Power, IT Room, Process & Machine, Building, and Security Management. It acts as a solution ecosystem, delivering guaranteed compatibility across key application areas and leveraging open standards across both Schneider Electric and third-party offers.

Our single, open platform enables significant savings on design, installation, and commissioning time, as well as on hardware and software costs. It can accommodate new technologies as they emerge without the need for major reconfiguration. And because EcoStruxure integrated system architecture can be applied to both retrofits and new construction, you can achieve significant savings on capital and operational expenses across your entire enterprise.

Most importantly, our EcoStruxure solution for green buildings enables the aggregation of data from multiple systems – allowing you to see, measure, and manage energy use across your building portfolio. Building end users, such as facility managers, office workers, students, or staff can see and manage the information that is most important to them. Facility and security personnel can also access information and receive alerts remotely so they can manage building systems from anywhere –saving time and money, increasing productivity, and resolving issues more quickly and efficiently. With technology available today an asset manager can monitor and manage the performance of an entire portfolio of buildings remotely from anywhere in the world.

EcoStruxure solutions for high performance green buildings are customized and configured to allow building systems and enterprise-wide portfolios to operate in the most efficient manner possible. By best serving the needs of the occupants, the building owner, and the environment now and in the future, EcoStruxure helps you to attain triple bottom line results.



**Dr. Natalie Essig<sup>(1)</sup>,  
Vincent Peyramale<sup>(2)</sup>, Germany  
Dr. Marjana Šijanec Zavrl<sup>(3)</sup>, Slovenia**

## **Open House: European Open Source Methodology to Assess the Sustainability of Buildings**

<sup>(1), (2)</sup> Fraunhofer-Institute for Building Physics IBP

<sup>(3)</sup> ZRMK

E-mail: [natalie.essig@ibp.fraunhofer.de](mailto:natalie.essig@ibp.fraunhofer.de)  
[vincent.peyramale@ibp.fraunhofer.de](mailto:vincent.peyramale@ibp.fraunhofer.de)  
[marjana.sijanec@gi-zrmk.si](mailto:marjana.sijanec@gi-zrmk.si)

### **ABSTRACT**

The contribution presents the development of a new European building assessment methodology OPEN HOUSE. Central in the OPEN HOUSE concept are transparency and collective development in an open way across the EU. Nineteen partners from eleven EU-countries have participated in the development of the FP7 OPEN HOUSE methodology ([www.openhouse-fp7.eu](http://www.openhouse-fp7.eu)).

The methodology is based on existing standards and methodologies as well as on European and international assessment methods, like LEED, BREEAM, HQE or DGNB. A special effort is put in applicability, feasibility, ranking and weighting of indicators in specific conditions of European countries. The experience gained from real case studies with the OPEN HOUSE methodology will be exemplified and further analyzed by taking the real case example of the building "Zentrum für Umweltbewusstes Bauen" (ZUB), which acts as a demonstration and research building in the German city Kassel.

## 1. INTRODUCTION

Buildings play a major role in societies but they are also responsible for important impacts on natural environment in terms of pollution and resources consumption. With the growing global population aspiring for high-level health and comfort, resources will have to be managed more efficiently if we want to ensure a sustainable development. In particular, a life-cycle-thinking approach has to be adopted in the building sector in order to encourage decisions with positive long-term impacts.

Decision-making requires knowledge on building performance and many assessment methods have been developed world-wide to evaluate the sustainability of buildings. The first generation of tools, like the "British Research Establishments Environmental Assessment Method" (BREEAM) in 1990 or the American label "Leadership in Energy and Environmental Design" (LEED) in 1996, was exclusively focused on the assessment of the environmental performance. The second generation, like the "DGNB Certificate" in 2009, includes social and economic aspects. With European research projects like OPEN HOUSE, SuPerBuildings or the standardization of ISO TC 59/SC 17 and CEN/TC 350, a process has been initialised to harmonise all these approaches.

The European project OPEN HOUSE has been established under the framework of a FP7 R&D programme by a European consortium of 19 partners from research institutions, the building industry and the political sector. Running from February 2010 to July 2013, its objective is to merge existing methodologies for sustainability assessment of buildings towards a common view. With the aim of being widely adopted in Europe, the OPEN HOUSE methodology is developed in a fully transparent, collective and open process, with extensive communication and interaction between all stakeholders.

Only EU-wide discussion towards a common approach can produce an EU-wide assessment methodology for the sustainability of buildings.

## 2. OPEN HOUSE METHODOLOGY

The OPEN HOUSE methodology has been developed on the basis of existing methodologies, international initiatives like iisBE or SB Alliance as well as standards from ISO TC 59/SC 17 and CEN/TC 350. It also includes outcomes from further and current EU projects, like LENSE or SuPerBuildings, with the adoption of a common structure for sustainability assessment of buildings. Thus, the OPEN HOUSE methodology is composed of six categories (see Figure 1):

- Environmental Quality
- Economic Quality
- Social/Functional Quality
- Technical Characteristics
- Process Quality
- and The Location.

The three classic pillars of sustainability (Environment – Economic – Social) are part of the main assessment and equally weighted. The other categories are evaluated separately.



Figure 1: OPEN HOUSE categories for the sustainability assessment of buildings

The analysis of more than 60 assessment methodologies led to the identification of more than 500 indicators. Finally, 56 sustainability indicators were selected after being grouped into the different categories and tested for their acceptability and feasibility in different European countries. This set of indicators is optimised for office buildings. Furthermore, 30 of them were identified by the project partners as essential for the sustainability assessment and highlighted as “core indicators” (see Figure 2).

### 3. OPEN HOUSE SCORING SYSTEM

For each indicator a maximum of 100 points can be achieved: the baseline of 10 points is obtained by fulfilling the standard of the specific EU country – the maximum by achieving best practices towards sustainability goals (e.g. targets of the EU in 2020).

The indicators and also their sub-indicators can be weighted from 0 to 4. This weighting factor depends on the relevance in the European country where the system will be applied and also on the specific building type. Thanks to feedback from case studies, questionnaires and workshops specific weights and benchmarks will be developed for each European country to take in account regional particularities.

		OPEN HOUSE Full Sytem	OPEN HOUSE Core System
Environmental Quality	1.1 Global Warming Potential (GWP)		
	1.2 Ozone Depletion Potential (ODP)		
	1.3 Acidification Potential (AP)		
	1.4 Eutrophication Potential (EP)		
	1.5 Photochemical Ozone Creation Potential (POCP)		
	1.6 Risks from materials		
	1.7 Biodiversity and Depletion of Habitats		
	1.8 Light Pollution		
	1.9 Non-Renewable Primary Energy Demand (PEnr)		
	1.10 Total Primary Energy Demand and % of Renewable Primary Energy		
	1.11 Water and Waste Water		
	1.12 Land use		
	1.13 Waste		
	1.14 Energy efficiency of building equipment (lifts, escalators etc.)		
Social / Functional Quality	2.1 Barrier-free Accessibility		
	2.2 Personal Safety and Security of Users		
	2.3 Thermal Comfort		
	2.4 Indoor Air Quality		
	2.5 Water Quality		
	2.6 Acoustic Comfort		
	2.7 Visual Comfort		
	2.8 Operation Comfort		
	2.9 Service Quality		
	2.10 Electro Magnetic Pollution		
	2.11 Public Accessibility		
	2.12 Noise from Building and Site		
	2.13 Quality of the Design and Urban Development of the building and Site		
	2.14 Area Efficiency		
	2.15 Conversion Feasibility		
	2.16 Bicycle Comfort		
	2.17 Responsible Material Sourcing		
	2.18 Local Material		
Economic Quality	3.1 Building-related Life Cycle Costs (LCC)		
	3.2 Value Stability		
Technical Characteristics	4.1 Fire Protection		
	4.2 Durability of the structure and Robustness		
	4.3 Cleaning and maintenance		
	4.4 Resistance against hail, storm high water and earthquake		
	4.5 Noise Protection		
	4.6 Quality of the building shell		
	4.7 Ease of Deconstruction, Recycling, and Dismantling		
Process Quality	5.1 Quality of the Project's Preparation		
	5.2 Integral Planning		
	5.3 Optimization and Complexity of the Approach to Planning		
	5.4 Evidence of Sustainability during Bid Invitation and Awarding		
	5.5 Construction Site impact/ Construction Process		
	5.6 Quality of the Executing Contractors/Pre-Qualification		
	5.7 Quality Assurance of Construction Execution		
	5.8 Commissioning		
	5.9 Monitoring, Use and Operation		
The location	6.1 Risks at the Site		
	6.2 Circumstances at the Site		
	6.3 Options for Transportation		
	6.4 Image and Condition of the Location and Neighbourhood		
	6.5 Vicinity to amenities		
	6.6 Adjacent Media, Infrastructure, Development		

Figure 2: OPEN HOUSE indicators: Full system and Core system

#### 4. OPEN HOUSE CASE STUDIES ALL OVER EUROPE

In order to refine the methodology and identify national practices, OPEN HOUSE indicators have been tested in 67 case studies distributed all over Europe.

Two kinds of assessments have been conducted during the case studies:

- Basic & Quick Sustainability Assessment: to get a first idea of the sustainability level and proposes actions to improve it. Evaluation of the building performance based on assumptions.
- Complete Sustainability Assessment: to give a whole overview of the sustainability performance of a building. Evaluation of the building performance based on detailed documentation.





Figure 3: OPEN HOUSE case studies all over Europe

## 5. OPEN HOUSE ASSESSMENT PROCESS AND TOOLS

The OPEN HOUSE assessment process was developed on the basis of the analysis of the existing certification processes and is taking in account the expectations from the main actors of the building sector. This analysis reveals a lack of a user-friendly and free tool to assess the sustainability of buildings. Moreover, high quality reports are reserved to a restricted group of experts with high experience in assessing buildings. The OPEN HOUSE assessment process covers these gaps by offering a free web-based tool to lead the assessment and automatically produce a high quality standardized report of building performance. More information could be found under [www.openhouse-fp7.eu](http://www.openhouse-fp7.eu).

Every web user will be able to use this online tool to carry out a self-evaluation of the sustainability of the project. If OPEN HOUSE had to become a recognised label, a third-verification of the building performance would be required and could be done by an approved OPEN HOUSE reviewer. For complex projects, the integration of an OPEN HOUSE assessor in the project team would be necessary to ensure the good processing of the data.

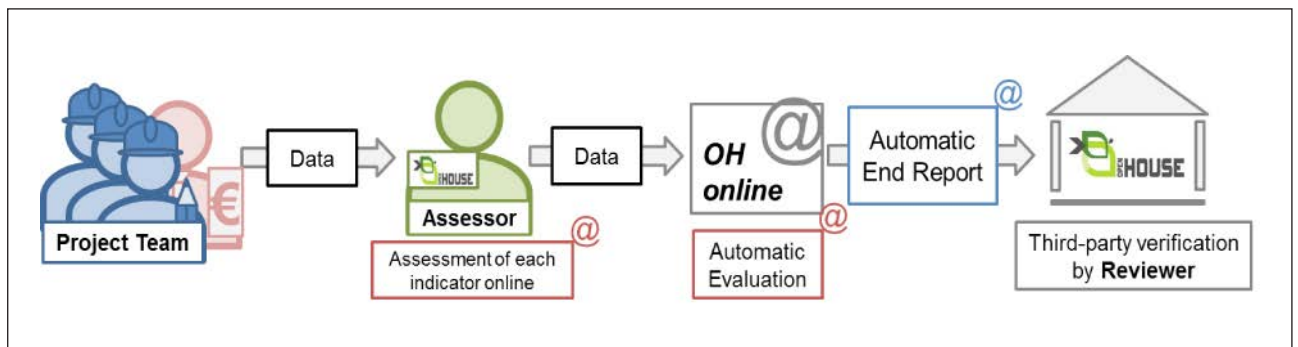

Figure 4: OPEN HOUSE assessment process

The assessment of the building performance is facilitated by the free provision of guidance documents and calculation tools on the OPEN HOUSE online platform. Indeed, any web user can download the complete Assessment Guideline, the Assessment Manual or have access to Assessment Tools.

The Assessment Guideline includes a comprehensive description of the 56 indicators. Each of them is detailed with Objective, Assessment Methodology, Calculation, Rating and Documentation Guidelines.

The Assessment Manual explains how to use the different tools and instructions are given on how to document the building performance using the provided templates. This harmonized working material offers the double advantage of clearly guiding the assessor and facilitating the reviewer's work.

The Assessment Tools include a LCC and LCA online tool to lead a simple or advanced LCC or LCA. For a simple LCA, a set of "constructions" has been predefined and can be selected by the assessor. For an advanced LCA, it is possible to define own "constructions" that exactly match the building components.

## CONCLUSION

The final version of the OPEN HOUSE methodology will be launched online in an open and transparent way, ensuring that any user can be aware of the development process and can further contribute to its improvement. The refinement process of the OPEN HOUSE methodology started with the detailed analysis of the feedback from case studies, will continue as an on-going process beyond the end of the project. The methodology will change as the technology and political landscape evolve.

The OPEN HOUSE project will give birth to an European methodology and open online platform for the sustainability assessment of buildings, providing free tools and guidelines as well as an open discussion platform. Therefore, it will set the basis for a better communication and comparison of building performance in European countries, paving the way for more sustainable construction practices.

## REFERENCES

BREEAM: [www.breeam.org](http://www.breeam.org)

DGNB: [www.dgnb.de](http://www.dgnb.de)

Ebert, T., Essig, N. and Hauser, G.: Green Building Certification Systems; Assessing Sustainability, International System Comparison; Economic Impact of Certifications; Edition Detail; Munich; 2011

Essig, N. and Eberl, S.: Case studies with the DGNB Certificate and the OPEN HOUSE methodology – practical experiences; Proceedings IALCCE, Vienna, 3-6 October 2012

LEED: [www.usgbc.org](http://www.usgbc.org)

LEnSE: [www.lensebuildings.com](http://www.lensebuildings.com)

OPEN HOUSE: [www.openhouse-fp7.eu](http://www.openhouse-fp7.eu)

Peyramale, V.: Documentation and process of assessment methods for sustainability in buildings. Analysis of existing concepts towards the development of the European project OPEN HOUSE; TU München; Munich; 2011

SB Alliance: <http://sballiance.org/>

SuPerBuildings: <http://cic.vtt.fi/superbuildings>



*the family values* company...  
...that *cares*

**Consolidated Contractors Company**  
[www.ccc.gr](http://www.ccc.gr)



The Velenje Coal Mine's top expertise, experience and technology are transferred into the international arena, thus opening numerous new business opportunities for us. At the Velenje Coal Mine, which, according to the assessment of international auditors, represents a reference point for the Western European mining industry, we still see opportunities for improvement, progress and development of new technologies which will continue to bring a competitive advantage in the open energy market throughout the following decades. The marketing and advocacy of our rich mining expertise in various projects has resulted from a year-long investment in the development of technologies and our know-how, which we intend to continue in the following decades.

## FEELING FOR THE FUTURE

### MINE CONSTRUCTION PRODUCTS AND SERVICES

Mine construction products and services comprise tunnel construction, road construction, construction and refurbishment of hydropower plants, closing down of mining sites, blasting and demolition, geotechnical works, production of concrete mixes and stone aggregates.



**RGP, d. o. o.**

Rudarska 6  
3320 Velenje  
Slovenia

tel.: +386 (0)3 898 21 70

fax: +386 (0)3 898 21 52

[www.rgp.si](http://www.rgp.si)





SPORTS BOTTLE



### AQUAVALLIS™ SPORTS BOTTLE

Buying and using bottled water places a heavy burden on the environment, since more than 80% of plastic bottles end up in an environment where they cannot be recycled. These bottles can take more than 200 years to decompose. Based on successful development of the AquaVallis™ programme, we managed to integrate the basic filtering material into a plastic sports bottle. The housing of the sports bottle is made of health-safe polymer materials with relevant FDA certificates.

The AquaVallis™ sports bottle is primarily aimed at active people, recreational and professional athletes, hikers, scouts, travellers in regions with no drinking water, troops, civil protection teams, and all eco-conscious people concerned for the future of our planet.



AQUAVALLIS, IT'S ALL ABOUT THE HEALTH!

The data in the table are relevant for all AquaVallis™ filtration systems.



The AquaVallis™ filtration system is integrated in the sports bottle.



HTZ Velenje, I.P., d.o.o. (AquaVallis programme)  
Partizanska cesta 78, SI-3320 Velenje, Slovenia

info@aquavallis.si  
www.aquavallis.si  
www.sportnaplastenka.si



**Organised by:**

Slovenian Chamber of Engineers | World Federation of Engineering Organisations

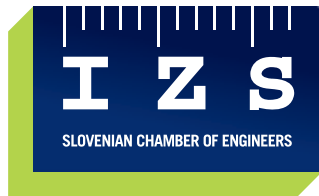

**Patrons:**

UNESCO | President of the Republic of Slovenia, Dr. Danilo Türk | The City of Ljubljana



**Organising Committee:**

WEF National Organising Committee | WFEO International Advisory Board

**In co-operation with:**

WCCE | ECEC | ECCE | Green Building Council Slovenia | Slovenian Academy of Engineering |  
Association of Engineering Societies in Slovenia

# World Engineering Forum 2012

[www.wef2012.si](http://www.wef2012.si)



## Supporting Partners:

Engineers Chamber of Montenegro | National and University Library | Serbian Chamber of Engineers | Croatian Chamber of Civil Engineers | Chamber of Certified Architects and Engineers of Macedonia | Trimo, d.d. | Hidria, d.d. | Slovenian National Building and Civil Engineering Institute | Aerodrom Ljubljana |

## Main sponsors:



## Sponsors:



Gradbeni inštitut ZRMK  
Building and Civil Engineering Institute



